

Copeland

Electronics Peripherals Catalog

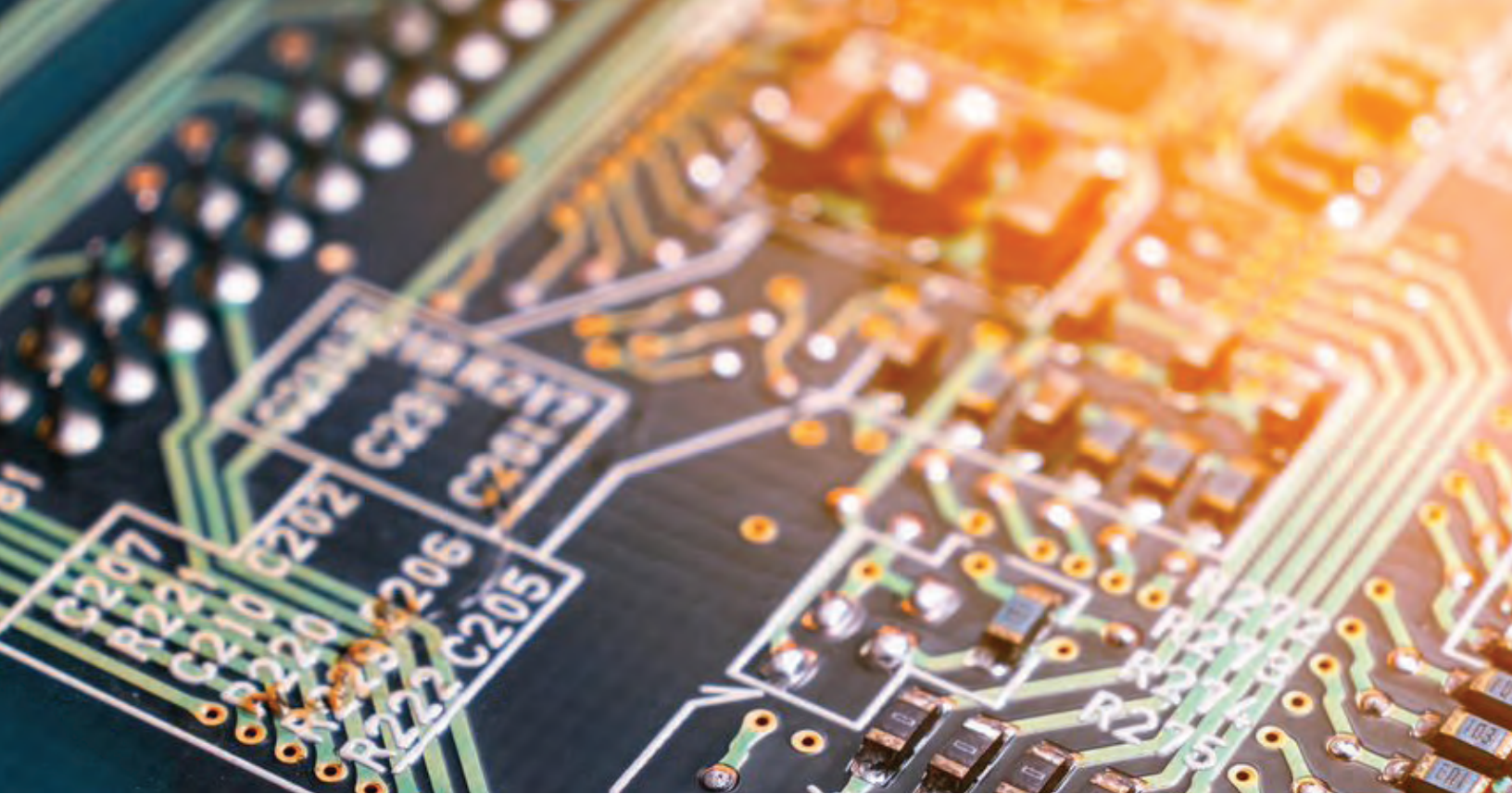

026-1904 Rev 15

CONTENTS

TEMPERATURE SENSOR	
OUTDOOR TEMPERATURE SENSOR (P/N 201-1152)	01
NSF APPROVED TEMPERATURE SENSOR (P/N 201-1160)	02
HIGH TEMPERATURE SENSOR (P/N 201-1191)	03
HIGH TEMPERATURE SENSOR (P/N 201-5000)	04
COIL INLET TEMPERATURE SENSOR (P/N 501-1125)	05
TEMPERATURE SENSOR WITH SLIDER OVERRIDE (P/N 201-2005)	06
TEMPERATURE SENSOR WITH SLIDER (P/N 201-2006)	09
SPACE TEMPERATURE SENSOR (P/N 201-2007)	11
SPACE TEMPERATURE SENSOR (P/N 809-6590)	12
4" STAINLESS STEEL TEMPERATURE SENSOR (P/N 201-0041)	13
8" STAINLESS STEEL TEMPERATURE SENSOR (P/N 201-2008)	15
8" STAINLESS STEEL TEMPERATURE SENSOR (P/N 201-2009)	16
18" STAINLESS STEEL TEMPERATURE SENSOR (P/N 201-2018)	17
12" STAINLESS STEEL TEMPERATURE SENSOR (P/N 201-2112)	18
GENERAL PURPOSE TEMPERATURE SENSOR (P/N 501-1121)	19
GENERAL PURPOSE TEMPERATURE SENSOR (P/N 501-1122)	20
GENERAL PURPOSE TEMPERATURE SENSOR (P/N 501-1129)	21
GENERAL PURPOSE TEMPERATURE SENSOR (P/N 501-1134)	22
DEFROST TERMINATION TEMPERATURE SENSOR (P/N 501-1127)	23
DEFROST TERMINATION TEMPERATURE SENSOR (P/N 501-1135)	24
COIL OUTLET TEMPERATURE SENSOR (P/N 501-1126)	25
RETURN AIR TEMPERATURE SENSOR (P/N 501-1128)	26
20" EVAPORATOR TEMPERATURE SENSOR (P/N 501-6150)	27
PRODUCT SIMULATOR TEMPERATURE SENSOR (P/N 508-910X)	28
WALL-MOUNTED RH SENSOR AND RH/TEMPERATURE SENSOR (P/N 203-5751, 203-5752, AND 203-5756)	29
HUMIDITY SENSOR	
INDOOR HUMIDITY SENSOR (P/N 203-5753)	32
OUTDOOR HUMIDITY SENSOR (P/N 203-5754)	33
DUCT-MOUNTED HUMIDITY SENSOR (P/N 203-5771)	34

CARBON DIOXIDE SENSOR	
CARBON DIOXIDE SENSOR (P/N 210-2000)	36
CARBON DIOXIDE SENSOR (P/N 510-2001)	40
DEWPOINT SENSOR	
WALL-MOUNT DEWPOINT SENSOR (P/N 210-2011)	42
OUTDOOR DEWPOINT SENSOR (P/N 210-2010)	46
LIGHT LEVEL SENSOR (P/N 206-0002)	48
PMAC	
SINGLE CHANNEL PMAC (P/N 851-1010)	49
SINGLE CHANNEL PMAC (P/N 851-1021)	51
SINGLE CHANNEL PMAC (P/N 851-1030)	53
SINGLE CHANNEL PMAC (P/N 851-1040)	55
TERMINAL	
HAND-HELD TERMINAL (P/N 814-3110)	57
OTHER COMPONENTS AND DEVICES	
LIGHT DIMMING MODULE KIT (P/N 603-0400 AND 603-0410)	58
DEFROST TIMER BOARD (P/N 537-3047)	61
CARBON DIOXIDE ASPIRATION BOX - DUCT ENCLOSURE (P/N 210-2009)	65
DIGITAL SCROLL CONDENSER BOARD (P/N 810-3250)	66
DPC-5 DEWPOINT TO TEMPERATURE CONVERTER (P/N 812-0102)	68
AC POWER METER (P/N 250-0450)	69
NEW CENTER-TAPPED TRANSFORMERS (P/N 640-00XX)	72
HOT FOOD TEMPERATURE MONITOR (P/N 508-9121)	73
800-2XX0 PRESSURE TRANSDUCERS	74
XM SERIES CASE CONTROLS (P/N 318-6522, 318-6601, 318-6702)	76
OTHER PERIPHERALS	

Outdoor Temperature Sensor

P/N 201-1152

Overview

The 201-1152 temperature sensor is designed to measure outdoor air temperature. The sensor is designed for mounting in a standard ½" knock out. The temperature sensor uses a 10K Ω thermistor. The thermistor is enclosed in a stainless steel housing. The sensor has two short 22 AWG black leads.

Installation

When installing the sensor, the open portion of the sensor should be facing down to allow for water drainage. The sensor should be secured to any enclosure with a ½" knockout. The ½" knockout nut is not provided with the sensor. The field terminations should be made inside an enclosure using water tight connectors, such as Blue Dolphins (P/N 110-1000) or 3M UR (P/N 110-9907) connectors.

The sensor connections to the input point on the 16AI board are not polarity sensitive. One black wire is connected to the 0V input on the input board. The other black wire is connected to the SIG input on the input board.

The dip switch for the 16AI input should be set to the ON position.

Resistance Chart

The accuracy of the resistor can be verified using an Ohm meter. The chart below shows the resistance for various temperatures.

Temperature (°F)	Temperature (°C)	Resistance (Ohms)
-40	-40	336,450
-30	-34	234,170
-20	-29	165,210
-10	-23	118,060
0	-18	85,399
10	-12	62,493
20	-7	46,235
30	-1	34,565
40	4	26,100
50	10	19,899
60	16	15,311
70	21	11,883
80	27	9,299
90	32	7,334
100	38	5,828
110	43	4,664
120	49	3,758
130	54	3,048
140	60	2,488
150	66	2,042
160	71	1,686
170	77	1,400
180	82	1,169
190	88	981
200	93	827

NSF Approved Temperature Sensor

P/N 201-1160

Overview

The 201-1160 is a NSF approved temperature sensor. It is suited for use in all food service applications. The temperature sensor has a 10K Ω thermistor. The thermistor is enclosed in a stainless steel housing with FDA-EP2 epoxy. The sensor has a white 20' pigtail. The wire NSF approved 22 AWG/2 Conductor. The sensor has been tested to maintain less than 0.72°F error between -40°F and 248°F.



NSF Approved Temperature Sensor

Installation

The sensor connections to the input point on the 16AI board are not polarity sensitive. The sensor is connected as shown in the Sensor Wiring diagram below. The sensor can be wired to any available point on the 16AI board. Connect one lead to the 0V input, and connect the other lead to the SIG input.

The dip switch for the 16AI input should be set to the ON position.

The sensor does not include any mounting material; it can be secured with a cable tie or clamp. The sensor can also be immersed in liquid.

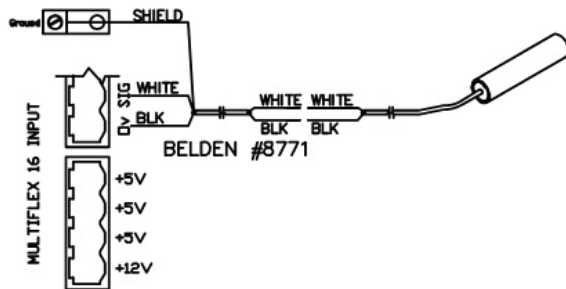

Sensor Wiring Diagram

Resistance Chart

The accuracy of the resistor can be verified using an Ohm meter. The chart below shows the resistance for various temperatures.

Temperature (°F)	Temperature (°C)	Resistance (Ohms)
-40	-40	336, 450
-30	-34	234, 170
-20	-29	165, 210
-10	-23	118, 060
0	-18	85, 399
10	-12	62, 493
20	-7	46, 235
30	-1	34, 565
40	4	26, 100
50	10	19, 899
60	16	15, 311
70	21	11, 883
80	27	9, 299
90	32	7, 334
100	38	5, 828
110	43	4, 664
120	49	3, 758
130	54	3, 048
140	60	2, 488
150	66	2, 042
160	71	1, 686
170	77	1, 400
180	82	1, 169
190	88	981
200	93	827

High Temperature Sensor

P/N 201-1191

Overview

The 201-1191 is Copeland's high temperature sensor. It is suited for use in any high temperature application. The temperature sensor has a 100K Ω thermistor. The thermistor is enclosed in a nickel-plated brass shell with epoxy. The sensor has a white 15' twisted pair cable attached. The cable is comprised of two 24 AWG Teflon coated conductors. The housing is designed to be secured using a tie wrap for easy pipe mounting.



High Temperature Sensor

Resistance Chart

The accuracy of the resistor can be verified using an Ohm meter. The chart below shows the resistance for various temperatures.

Temperature (°F)	Temperature (°C)	Resistance (Ohms)
0	-18	844,470
20	-7	460,483
40	4	260,020
60	16	153,271
80	27	92,953
100	38	58,064
125	52	33,491
150	66	20,070
175	79	12,451
200	93	7,970
225	107	5,249
250	121	3,548
275	135	2,456
300	149	1,737
350	177	921
400	204	523
450	232	314
500	260	198

Installation

Dimensions	0.25"x0.25"x1.00"L
Housing Material	Brass
Max. Continuous Operating Temperature	400°F (204°C)
Max. Error	+/- 2° for 0°F -150°F +/- 4° for 150°F -500°F

The sensor connections to the input point on the 16AI board are not polarity sensitive. The sensor is connected as shown in the Sensor Wiring diagram below. The sensor can be wired to any available point on the 16AI board. Connect one lead to the 0V input, and connect the other lead to the SIG input.

The dip switch for the 16AI input should be set to the ON position.

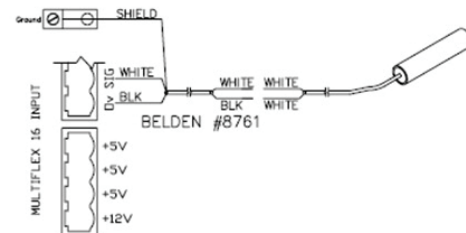

Sensor Wiring Diagram

E2 Programming

The analog input sensor type is ATP High Temp.

High Temperature Sensor

P/N 201-5000

Overview

The 201-5000 is Copeland's high temperature sensor. It is suited for use in any high temperature application. The temperature sensor is a 10K Ω thermistor.

The thermistor is enclosed in a nickel-plated brass shell with epoxy. The sensor has a green 20' twisted pair cable attached.



High Temperature Sensor

Installation

The sensor connections to the input point on the 16AI board are not polarity sensitive. The sensor is connected as shown in the Sensor Wiring diagram. The sensor can be wired to any available point on the 16AI board. Connect one lead to the 0V input, and connect the other lead to the SIG input.

The dip switch for the 16AI input should be set to the ON position.

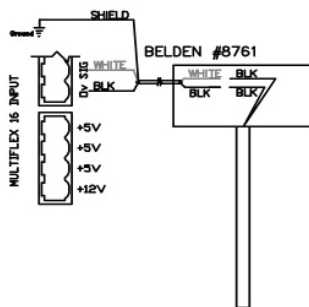

NOTES:

1. ONLY CONNECT SHIELD LEAD INSIDE CONTROL PANEL.
2. LEADS ARE NOT POLARITY SENSITIVE AT SENSOR
3. DIP SWITCH ON

Sensor Wiring Diagram

Resistance Chart

The accuracy of the resistor can be verified using an Ohm meter. The chart below shows the resistance for various temperatures.

Temperature (°F)	Temperature (°C)	Resistance (Ohms)
-40	-40	336,450
-30	-34	234,170
-20	-29	165,210
-10	-23	118,060
0	-18	85,399
10	-12	62,493
20	-7	46,235
30	-1	34,565
40	4	26,100
50	10	19,899
60	16	15,311
70	21	11,883
80	27	9,299
90	32	7,334
100	38	5,828
110	43	4,664
120	49	3,758
130	54	3,048
140	60	2,488
150	66	2,042
160	71	1,686
170	77	1,400
180	82	1,169
190	88	981
200	93	827

Coil Inlet Temperature Sensor

P/N 501-1125

Overview

The 501-1125 is Copeland's coil inlet temperature sensor. It is designed for measuring the coil temperature of an evaporator. The temperature sensor has a 10K Ω thermistor. The thermistor is enclosed in a nickel-plated brass shell with epoxy. The sensor has a blue 20' pigtail. The wire is a 22 AWG CL3X cord with 2 conductors. The cable is UL rated for 194°F (90°C). The sensor has been tested to maintain less than 0.72°F error between -40°F and 248°F.



Coil Inlet Temperature Sensor

Installation

The sensor connections to the input point on the 16AI board are not polarity sensitive. The sensor is connected as shown in the Sensor Wiring Diagram. The sensor can be wired to any available point on the 16AI board. Connect one lead to 0V input, and connect the lead to the SIG input. The sensor has a male mux connector for use with a TD3 or Case Controller.

The dip switch for the 16AI input should be set to the ON position. The sensor includes a Panduit U119 cable tie. The sensor should be secured to the inlet of the evaporator coil using the cable tie provided with the sensor.

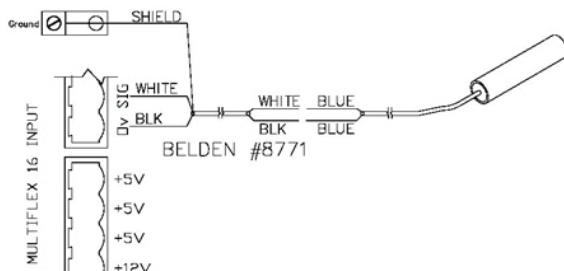

Sensor Wiring Diagram

Resistance Chart

The accuracy of the resistor can be verified using an Ohm meter. The chart below shows the resistance for various temperatures.

Temperature (°F)	Temperature (°C)	Resistance (Ohms)
-40	-40	336,450
-30	-34	234,170
-20	-29	165,210
-10	-23	118,060
0	-18	85,399
10	-12	62,493
20	-7	46,235
30	-1	34,565
40	4	26,100
50	10	19,899
60	16	15,311
70	21	11,883
80	27	9,299
90	32	7,334
100	38	5,828
110	43	4,664
120	49	3,758
130	54	3,048
140	60	2,488
150	66	2,042
160	71	1,686
170	77	1,400
180	82	1,169
190	88	981
200	93	827

Temperature Sensor With Slider Override

P/N 201-2005

Overview

The 201-2005 is a wall-mounted space temperature sensor. It is suited for a wide variety of applications. The temperature sensor has a 10K Ω thermistor. The sensor has been tested to maintain less than 0.72°F error between -40°F and 248°F.

Installation

The sensor has three outputs. The first output is for the 10K Ω thermistor (labeled +/- on the terminal strip). The second output is for the slider (labeled SET on the terminal strip). The third output is for the momentary bypass button (labeled O/R on the terminal strip). If three separate two conductor wires are used for connecting the sensor to a 16AI board, the leads are not polarity sensitive. However, if a single four-conductor wire is used, the sensor must be wired as shown in the Sensor Wiring Diagram.

The dip switches for the 16AI inputs should be set to the ON position. The J3 jumpers on the temperature sensors should be in down position for the bypass button to operate as a separate input. The E2 does not recognize a direct short on the temperature sensor to change from occupied to unoccupied.

The sensor does not include any mounting hardware. The wall plate has two holes for mounting the sensor using #8 hardware. The $\frac{3}{4}$ " x $1\frac{1}{4}$ " hole is for routing the sensor cable(s) into the temperature sensor.



Temperature Sensor with Slider Override

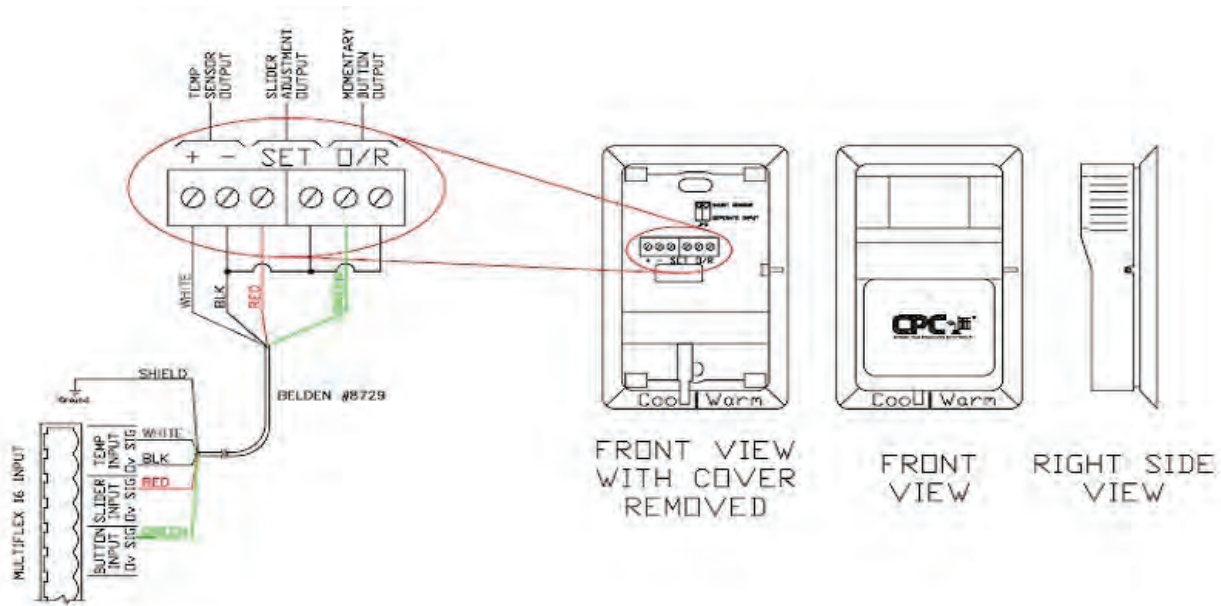

Sensor Wiring Diagram

Programming Adjustable Temperature Sensor into AHU Application

A. Adding Temperature Sensor Input to a 16AI Board

1. Press **Alt** + **I**.
2. Use the cursor pad to highlight the application field for the correct board and point.
3. Press **Enter** to setup the input.
4. Press **1** to select an analog input type.
5. Type in the desired name for the sensor and press **Enter**.
6. Press **↵** to accept the input.

B. Add Slider Input to a 16AI Board

1. Use the cursor pad to highlight the application field for the correct board and point.
2. Press **Enter** to setup the input.
3. Press **1** to select an analog input type.
4. Type in the desired name for the sensor and press **Enter**.
5. Highlight the **Sensor Type** field (default value is Temperature).
6. Press **F4**.
7. Scroll down using **Page Down** and/or the cursor pad down arrow to **20k Pot Adjustment B** and press **Enter**.
8. Highlight the **Select Eng. Units** field (default value is DF).
9. Press **F4**.
10. Scroll down using **Page Down** or the cursor pad down arrow to **PCT 26** and press **Enter**.
11. Press **↵** to accept the input.

C. Adding Push Button Input to 16AI Board

1. Use the cursor pad to highlight the application field for the correct board and point.
2. Press **Enter** to setup the input.
3. Press **2** to select an analog input type.
4. Type in the desired name for the sensor and press **Enter**.
5. Highlight the **Push Button Mode** field (default value is No).
6. Press **Y** to change the value to **Yes**.
7. Press **↵** to accept the input.

D. Add Temperature Sensor Input into AHU Application

1. Press **Home** **F1** to enter the **AHU main screen**.
2. Use the cursor pad to highlight the correct AHU and press **F5** to setup the application.
3. Press **Ctrl** + **#3** to view the **C3: Inputs** tab. Use the cursor pad to highlight the **SPACE TEMP 1** field.
4. Press **F3** **Enter** **1** to change the input format to **Board: Point**.
5. Input the board and point for the space temperature sensor from **Step A**.

E. Add Slider Input into AHU Application

1. From the AHU setup, press **Ctrl** + **0** to view the **ADDITIONAL TABS** menu.
2. Press **I** to enter the **Stpt Reset** setup screen.
3. Press **Y** **Enter** to enable the setpoint reset feature.
4. Use the cursor pad to highlight the **RESET SENSOR** field.
5. Press **F3** **Enter** **1** to change the input format to **Board: Point**.
6. Input the board and point for the slider input from **Step B**.
7. The **Max SP Rst Heat** value and **Max SP Rst Cool** fields determine the temperature range of the slider. The range is used to modify the temperature setpoints on the **C2: Setpoint** tab.

When in cooling mode, sliding the slider to the far left position will make the controller temperature setpoint the value on the **C2: Setpoint** tab. Moving the slider to the far right position will make the controller temperature setpoint the value on the **C2: Setpoint** tab plus the value on the **Stpt Reset Max Sp Rst Cool** field.

In the following example, the desired cool setpoint is 74° and end user wants the ability to increase or decrease the temperature 2°, resulting in a 72° to 76° setpoint range. The **C2: Setpoint tab** cool setpoint will be 72°, and the **Stpt Reset Max Sp Rst Cool** value will be 4°.

The heating mode works in the reverse of the cooling mode. In heating mode, sliding the slider to the far right position will make the controller temperature setpoint the value on the **C2: Setpoint** tab. Moving the slider to the far left position will make the controller temperature setpoint the value on the **C2: Setpoint** tab minus the value on the **Stpt Reset Max Sp Rst Heat** field.

F. Adding Push Button Input into AHU Application

1. From the AHU setup, press **Ctrl** + **#3** to view the **C3: Inputs** tab.
2. Use the cursor pad to highlight the **BYPASS to OCC** field.
3. Press **F3** **Enter** **↓** to change the input format to **Board: Point**.
4. Input the board and point for the push button input from **Step C**.
5. The default time for the momentary bypass is 30 minutes. To change the bypass time, highlight the **BYPASS TO OCC** field.
6. Press **F3** **^6** to enter the Bypass Configuration Setup.
7. Change the **Bypass Duration** time to the desired duration.

Note: The push button on the temperature sensor can be used for any application that requires a momentary digital input. The example above is the most common use for the input.

Application Notes

The bypass button on the 201-2005 sensor does not function like the 809-6570 temperature sensor bypass. The 809-6570 temperature sensor bypass button produces a fixed resistance value across the temperature sensor wires. When this value is received by a MultiFlex RTU board, the system changes the occupancy status from occupied to unoccupied or unoccupied to occupied. When the J3 jumpers are in the up position, the 201-2005 sensor sends a direct short when the bypass button is selected. When the J3 jumpers are in the down position, the 201-2005 sensor sends a signal using the O/R output terminals.

Temperature Sensor With Slider

P/N 201-2006

Overview

The 201-2006 is a wall-mounted space temperature sensor. It is suited for a wide variety of applications. The temperature sensor has a 10K Ω thermistor. The sensor has been tested to maintain less than 0.72°F error between -40°F and 248°F

Installation

The sensor wiring diagram as shown in the Sensor Wiring diagram has two outputs. The first output is for the 10K Ω thermistor (labeled +/- on the terminal strip). The second output is for the slider (labeled SET on the terminal strip).

The dip switches for the 16AI inputs should be set to the ON position.

The sensor does not include any mounting hardware. The wall plate has two holes for mounting the sensor using #8 hardware. The 3/4" x 1 1/4" hole is for routing the sensor cable(s) into the temperature sensor.



Wall-Mounted Space Temperature Sensor

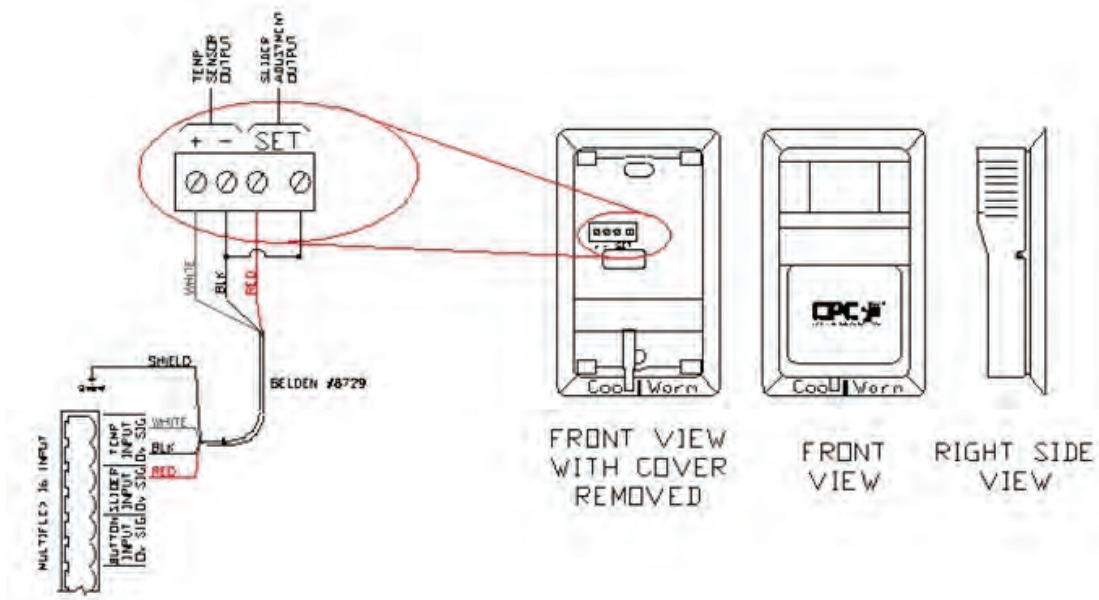

Sensor Wiring Diagram

Programming Adjustable Temperature Sensor into AHU Application

A. Adding Temperature Sensor Input to a 16AI Board

1. Press **Alt** + **I**.
2. Use the cursor pad to highlight the application field for the correct board and point.
3. Press **Enter** to setup the input.
4. Press **1** to select an analog input type.
5. Type in the desired name for the sensor and press **Enter**.
6. Press  to accept the input.

B. Add Slider Input to a 16AI Board

1. Use the cursor pad to highlight the application field for the correct board and point.
2. Press **Enter** to setup the input.
3. Press **1** to select an analog input type.
4. Type in the desired name for the sensor and press **Enter**.
5. Highlight the **Sensor Type** field (default value is Temperature).
6. Press **F4**.
7. Scroll down using **Page Down** and/or the cursor pad down arrow to **20k Pot Adjustment B** and press **Enter**.
8. Highlight the **Select Eng. Units** field (default value is DF).
9. Press **F4**.
10. Scroll down using **Page Down** or the cursor pad down arrow to **PCT 26** and press **Enter**.
11. Press  to accept the input.

C. Add Temperature Sensor Input into AHU Application

1. Press  **F1** to enter the **AHU main screen**.
2. Use the cursor pad to highlight the correct AHU and press **F5** to setup the application.
3. Press **Ctrl** + **# 3** to view the **C3: Inputs** tab. Use the cursor pad to highlight the **SPACE TEMP 1** field.
4. Press **F3** **Enter** **1** to change the input format to **Board: Point**.
5. Input the board and point for the space temperature sensor from **Step A**.

D. Add Slider Input into AHU Application

1. From the AHU setup, press **Ctrl** + **0** to view the **ADDITIONAL TABS** menu.
2. Press **U** to enter the **Stpt Reset** setup screen.
3. Press **Y** **Enter** to enable the setpoint reset feature.
4. Use the cursor pad to highlight the **RESET SENSOR** field.
5. Press **F3** **Enter** **1** to change the input format to **Board: Point**.
6. Input the board and point for the slider input from **Step B**.
7. The **Max SP Rst Heat** value and **Max SP Rst Cool** fields determine the temperature range of the slider. The range is used to modify the temperature setpoints on the **C2: Setpoint** tab.

When in cooling mode, sliding the slider to the far left position will make the controller temperature setpoint the value on the **C2: Setpoint** tab. Moving the slider to the far right position will make the controller temperature setpoint the value on the **C2: Setpoint** tab plus the value on the **Stpt Reset Max Sp Rst Cool** field.

In the following example, the desired cool setpoint is 74° and end user wants the ability to increase or decrease the temperature 2°, resulting in a 72° to 76° setpoint range. The **C2: Setpoint tab** cool setpoint will be 72°, and the **Stpt Reset Max Sp Rst Cool** value will be 4°.

The heating mode works in the reverse of the cooling mode. In heating mode, sliding the slider to the far right position will make the controller temperature setpoint the value on the **C2: Setpoint** tab. Moving the slider to the far left position will make the controller temperature setpoint the value on the **C2: Setpoint** tab minus the value on the **Stpt Reset Max Sp Rst Heat** field.

Space Temperature Sensor

P/N 201-2007

Overview

The 201-2007 is wall-mounted space temperature sensor. It is suited for a wide variety of applications. The temperature sensor has a 10K Ω thermistor. The sensor has been tested to maintain less than 0.72°F error between -40°F and 248°F.



Space Temperature Sensor

Installation

The sensor connections to the input point on the 16AI board are not polarity sensitive. The sensor is connected as shown in the Sensor Wiring diagram. The sensor can be wired to any available point on the 16AI board. Connect one lead to the 0V input, and connect the other lead to the SIG input.

The dip switch for the 16AI input should be set to the ON position.

The sensor does not include any mounting hardware. The wall plate has two holes for mounting the sensor with #8 hardware. The 3/4" x 1 1/4" hole is for routing the sensor cable into the temperature sensor.

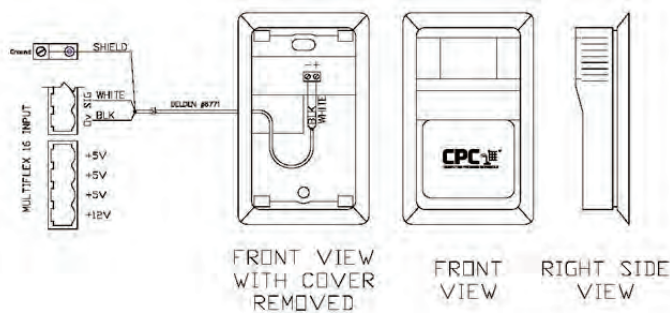

Sensor Wiring Diagram

Resistance Chart

The accuracy of the resistor can be verified using an Ohm meter. The chart below shows the resistance for various temperatures.

Temperature (°F)	Temperature (°C)	Resistance (Ohms)
-40	-40	336,450
-30	-34	234,170
-20	-29	165,210
-10	-23	118,060
0	-18	85,399
10	-12	62,493
20	-7	46,235
30	-1	34,565
40	4	26,100
50	10	19,899
60	16	15,311
70	21	11,883
80	27	9,299
90	32	7,334
100	38	5,828
110	43	4,664
120	49	3,758
130	54	3,048
140	60	2,488
150	66	2,042
160	71	1,686
170	77	1,400
180	82	1,169
190	88	981
200	93	827

Space Temperature Sensor

P/N 809-6590

Overview

The 809-6590 is wall mounted space temperature sensor. It is suited for a wide variety of applications. The temperature sensor has a 10K Ω thermistor. The sensor has been tested to maintain less than 0.72°F error between -40°F and 248°F



Space Temperature Sensor

Installation

The sensor connections to the input point on the 16AI board are not polarity sensitive. The sensor is connected as shown in the Sensor Wiring diagram. The sensor can be wired to any available point on the 16AI board. Connect one lead to the 0V input, and connect the other lead to the SIG input.

The dip switch for the 16AI input should be set to the ON position.

The sensor includes two mounting screws for mounting the sensor to a standard single gang box.

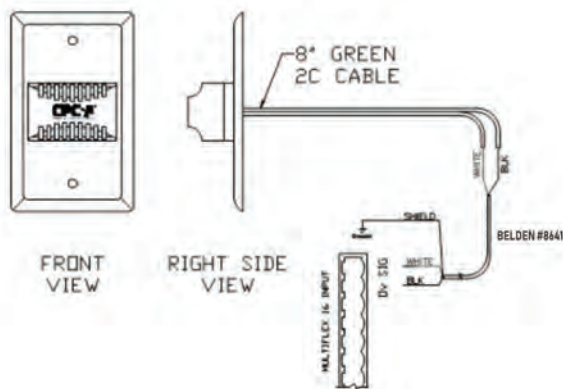

Sensor Wiring Diagram

Resistance Chart

The accuracy of the resistor can be verified using an Ohm meter. The chart below shows the resistance for various temperatures.

Temperature (°F)	Temperature (°C)	Resistance (Ohms)
-40	-40	336,450
-30	-34	234,170
-20	-29	165,210
-10	-23	118,060
0	-18	85,399
10	-12	62,493
20	-7	46,235
30	-1	34,565
40	4	26,100
50	10	19,899
60	16	15,311
70	21	11,883
80	27	9,299
90	32	7,334
100	38	5,828
110	43	4,664
120	49	3,758
130	54	3,048
140	60	2,488
150	66	2,042
160	71	1,686
170	77	1,400
180	82	1,169
190	88	981
200	93	827

4" Stainless Steel Temperature Sensor

P/N 201-0041

Overview

The 201-0041 is a 4" stainless steel insertion temperature sensor designed for measuring the air temperature in the following applications:

- Return Air for a Freezer Evaporator
- Return Air for a Cooler Evaporator
- HVAC Supply Air
- HVAC Return Air
- Immersion in concrete slabs

Installation

The sensor connections to the input point on the 16AI board are not polarity sensitive. The sensor is connected as shown in Figure 1. The sensor can be wired to any available point on the 16AI board. Connect one lead to the 0V input, and connect the other lead to the SIG input.

The dip switch for the 16AI input should be set to the ON position.

The temperature sensor has a 10K Ω thermistor. The thermistor is enclosed inside the stainless steel insertion probe. The junction box is used for securing the sensor and making the electrical connections. The sensor has been tested to maintain less than 0.72°F error between -40°F and 248°F.

The dip switch for the 16AI input should be set to the ON position.

The sensor does not include mounting hardware. Secure the sensor using the ½" NPT Male on the sensor shaft and the holes in the single gang box. Securing the temperature sensor using the ½" NPT Male thread allows for easy removal of the junction box and internal thermistor housing after installation.

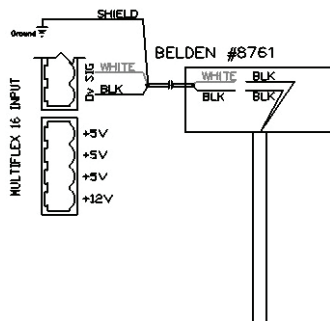

NOTES:



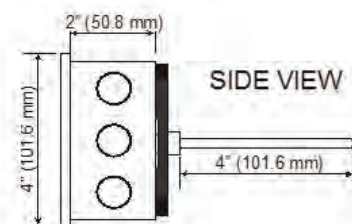
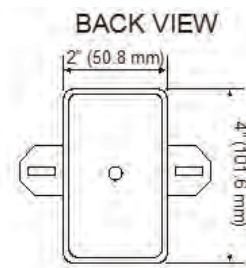

1. ONLY CONNECT SHIELD LEAD INSIDE CONTROL PANEL.
2. LEADS ARE NOT POLARITY SENSITIVE AT SENSOR
3. DIP SWITCH ON

Sensor Wiring Diagram



Temperature Sensor Dimensions

E2 Input Setup

1. Log into the E2 and press    (Input Status 2 screen).
2. Highlight the input point the Temperature Probe is connected to, and press  (Setup).
3. When prompted to select the data type, press  (Analog).

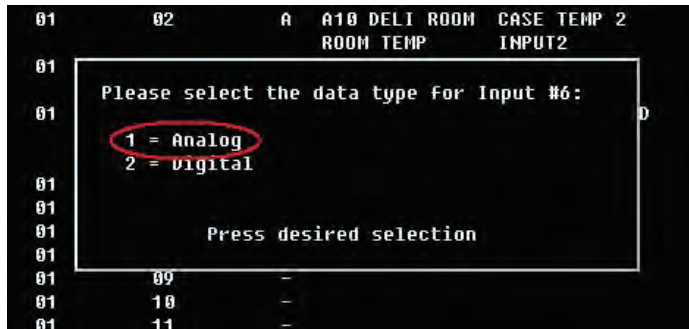

4. In the **Analog Input setup** screen, enter the following information in the fields listed below:
 - **Name:** A description of the sensor's function and/or location (e.g. INDOOR TEMP).
 - **Sensor Type:** Temperature
 - **Eng Units:** DF
5. Press  to save the changes and exit the screen.

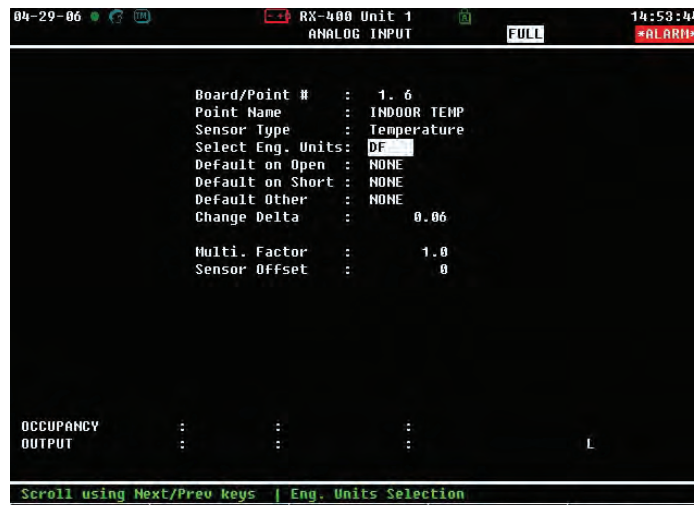

8" Stainless Steel Temperature Sensor

P/N 201-2008

Overview

The 201-2008 is an 8" stainless steel insertion temperature sensor designed for measuring the air temperature in the following applications:

- Return Air for a Freezer Evaporator
- Return Air for a Cooler Evaporator
- HVAC Supply Air
- HVAC Return Air
- Immersion in concrete slabs

The temperature sensor has a 10K Ω thermistor. The thermistor is enclosed inside the stainless steel insertion probe. The junction box is used for securing the sensor and making the electrical connections. The sensor has been tested to maintain less than 0.72°F error between -40°F and 248°F.

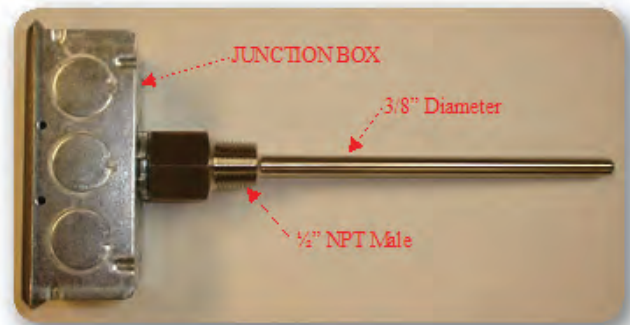

NOTE: This sensor (pictured above) is manufactured by Automation Components, Inc. (ACI) and is a registered trademark of that company

Installation

The sensor connections to the input point on the 16AI board are not polarity sensitive. The sensor is connected as shown below in the Sensor Wiring Diagram. The sensor can be wired to any available point on the 16AI board. Connect one lead to the 0V input, and connect the other lead to the SIG input.

The dip switch for the 16AI input should be set to the ON position.

The sensor does not include mounting hardware. Secure the sensor using the 1/2" NPT Male on the sensor shaft or the holes in the single gang box. Securing the temperature sensor using the 1/2" NPT Male thread allows for easy removal of the junction box and internal thermistor housing after installation.

8" Stainless Steel Temperature Sensor

P/N 201-2009

Overview

The 201-2009 is an 8" stainless steel insertion temperature sensor designed for measuring the air temperature in the following applications:

- Return Air for a Freezer Evaporator
- Return Air for a Cooler Evaporator
- HVAC Supply Air
- HVAC Return Air
- Immersion in concrete slabs

The temperature sensor has a 10K Ω thermistor. The thermistor is enclosed inside the 304 stainless steel insertion probe. The RTD accuracy of the sensor is $\pm 1^{\circ}\text{F}$.

Installation

The sensor connections to the input point on the 16AI board. The sensor connections to the input point on the 16AI board are not polarity sensitive. The sensor is connected as shown in the Sensor Wiring diagram. The sensor can be wired to any available point on the 16AI board. Connect one lead to the 0V input, and connect the other lead to the SIG input.

The dip switch for the 16AI input should be set to the ON position.

The sensor includes two $\frac{1}{2}$ " locknuts for easy installation in handy boxes or other enclosures with $\frac{1}{2}$ " knockouts. The sensor has an 8 foot lead, which is used to avoid condensation at the field connection.



NOTE: This sensor (pictured above) is manufactured by Automation Components, Inc. (ACI) and is a registered trademark of that company

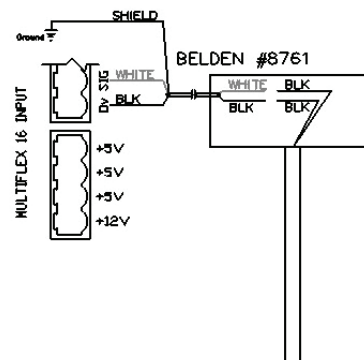

- NOTES:
1. ONLY CONNECT SHIELD LEAD INSIDE CONTROL PANEL.
 2. LEADS ARE NOT POLARITY SENSITIVE AT SENSOR
 3. DIP SWITCH ON

Sensor Wiring Diagram

18" Stainless Steel Temperature Sensor

P/N 201-2018

Overview

The 201-2018 is an 18" stainless steel insertion temperature sensor. It is designed for measuring the air temperature in the following applications:

- Return Air for a Freezer Evaporator
- Return Air for a Cooler Evaporator
- HVAC Supply Air
- HVAC Return Air

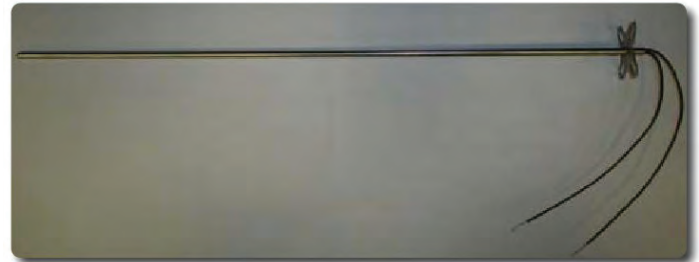

Stainless Steel Insertion Temperature Sensor

The temperature sensor has a 10K Ω thermistor. The thermistor is enclosed inside the stainless steel insertion probe. The junction box is used for securing the sensor and making the electrical connections. The sensor has been tested to maintain less than 0.72°F error between -40°F and 248°F.

Installation

The sensor connections to the input point on the 16AI board are not polarity sensitive. The sensor is connected as shown in the Sensor Wiring diagram. The sensor can be wired to any available point on the 16AI board. Connect one lead to the 0V input, and connect the other lead to the SIG input.

The dip switch for the 16AI input should be set to the ON position.

The sensor does not include mounting hardware. Drill a 3/16" hole from the top of the cooler to insert the probe. The hole must be sealed with silicon after installing the sensor. The sensor should be installed in the center of the cooler as shown in the Sensor Mounting diagram.

The accuracy of the resistor can be verified using an Ohm meter. The chart below shows the resistance for various temperatures.

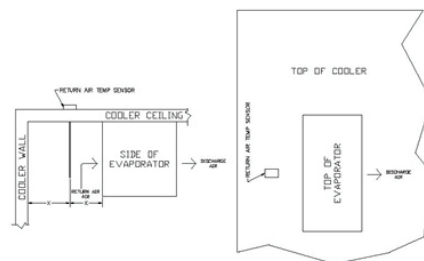

Sensor Mounting Location

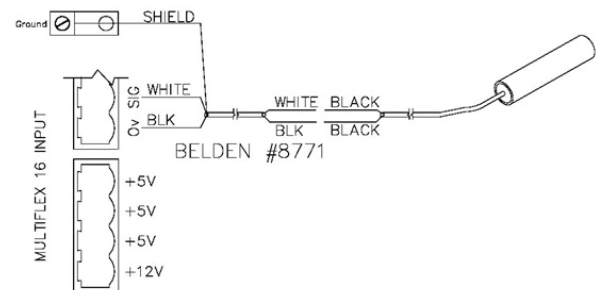

Sensor Wiring Diagram

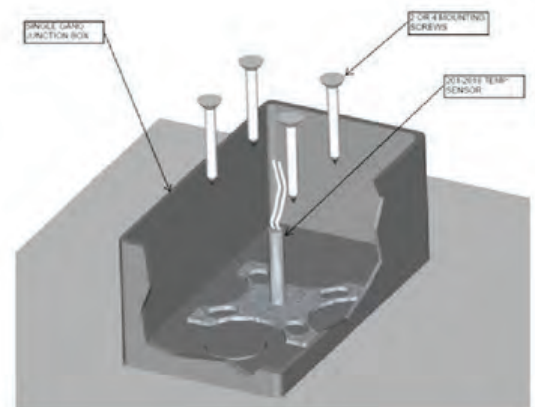

Sensor Mounting Diagram

12" Stainless Steel Temperature Sensor

P/N 201-2112

Overview

The 201-2112 is a 12" stainless steel insertion temperature sensor. It is designed for measuring the air temperature in the following applications:

- Return Air for a Freezer Evaporator
- Return Air for a Cooler Evaporator
- HVAC Supply Air
- HVAC Return Air

The temperature sensor has a 10K Ω thermistor. The thermistor is enclosed inside the stainless steel insertion probe. The junction box is used for securing the sensor and making the electrical connections. The sensor has been tested to maintain less than 0.72°F error between -40°F and 248°F.

Installation

The sensor connections to the input point on the 16AI board. The sensor connections to the input point on the 16AI board are not polarity sensitive. The sensor is connected as shown in the Sensor Wiring diagram. The sensor can be wired to any available point on the 16AI board. Connect one lead to the 0V input, and connect the other lead to the SIG input.

The dip switch for the 16AI input should be set to the ON position.

The sensor does not include mounting hardware. Drill a 1/4" hole for inserting the sensor. The hole must be sealed with silicon after installing the sensor. When mounting behind an evaporator, the sensor should be installed in the center of the cooler as shown in Sensor Dimensional diagram.

The junction box must be secured using the two tabs. The tabs have slotted holes for #8 screws.

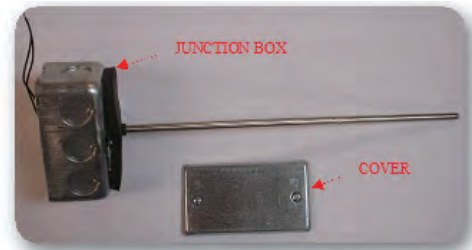

NOTE: This sensor (pictured above) is manufactured by Automation Components, Inc. (ACI) and is a registered trademark of that company

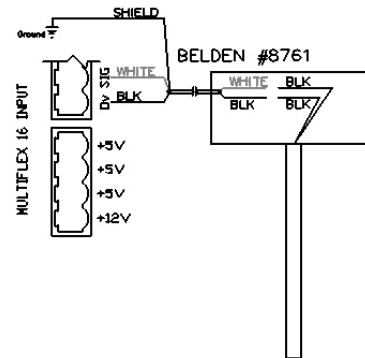

- NOTES:
1. ONLY CONNECT SHIELD LEAD INSIDE CONTROL PANEL.
 2. LEADS ARE NOT POLARITY SENSITIVE AT SENSOR
 3. DIP SWITCH ON

Sensor Wiring Diagram

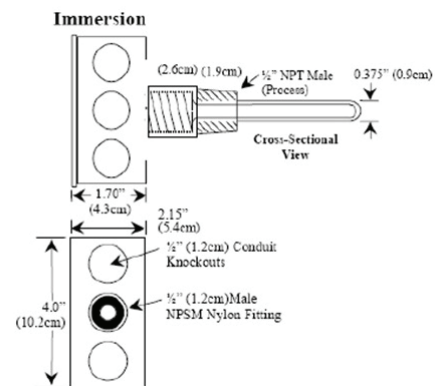

Sensor Dimensional Diagram

General Purpose Temperature Sensor

P/N 501-1121

Overview

The 501-1121 is Copeland's general purpose temperature sensor. It is suited for a wide variety of applications. The temperature sensor has a 10K Ω thermistor. The thermistor is enclosed in a nickel-plated brass shell with epoxy. The sensor has a green 10' pigtail. The wire is a 22 AWG CL3X cord with 2 conductors. The cable is UL rated for 194°F (90°C). The sensor has been tested to maintain less than 0.72°F error between -40°F and 248°F.



General Purpose Temperature Sensor

Installation

The sensor connections to the input point on the 16AI board are not polarity sensitive. The sensor can be wired to any available point on the 16AI board. Connect one lead to the 0V input, and connect the other lead to the SIG input. The sensor is connected as shown in the Sensor Wiring diagram.

The dip switch for the 16AI input should be set to the ON position.

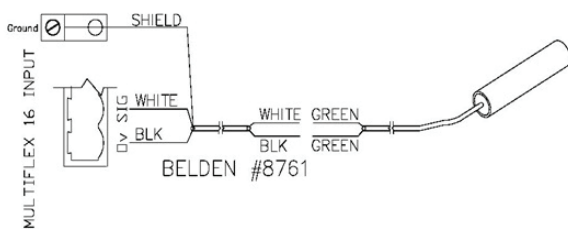

Sensor Wiring Diagram

The sensor includes a metal insulated clamp for securing the sensor. Mounting hardware is not included with the clamp. The sensor can also be secured using standard cable ties (not provided).



Sensor Clamp

Resistance Chart

The accuracy of the resistor can be verified using an Ohm meter. The chart below shows the resistance for various temperatures.

Temperature (°F)	Temperature (°C)	Resistance (Ohms)
-40	-40	336,450
-30	-34	234,170
-20	-29	165,210
-10	-23	118,060
0	-18	85,399
10	-12	62,493
20	-7	46,235
30	-1	34,565
40	4	26,100
50	10	19,899
60	16	15,311
70	21	11,883
80	27	9,299
90	32	7,334
100	38	5,828
110	43	4,664
120	49	3,758
130	54	3,048
140	60	2,488
150	66	2,042
160	71	1,686
170	77	1,400
180	82	1,169
190	88	981
200	93	827

General Purpose Temperature Sensor

P/N 501-1122

Overview

The 501-1122 is Copeland's general purpose temperature sensor. It is suited for a wide variety of applications. The temperature sensor has a 10K Ω thermistor. The thermistor is enclosed in a nickel-plated brass shell with epoxy. The sensor has a green 20' pigtail. The wire is a 22 AWG CL3X cord with 2 conductors. The cable is UL rated for 194°F (90°C). The sensor has been tested to maintain less than 0.72°F error between -40°F and 248°F.



General Purpose Temperature Sensor

Installation

The sensor connections to the input point on the 16AI board are not polarity sensitive. The sensor can be wired to any available point on the 16AI board. Connect one lead to the 0V input, and connect the other lead to the SIG input. The sensor is connected as shown in the Sensor Wiring diagram.

The dip switch for the 16AI input should be set to the ON position.

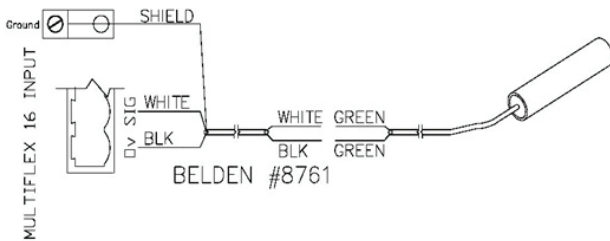

Sensor Wiring Diagram

The sensor includes a metal insulated clamp for securing the sensor. Mounting hardware is not included with the clamp. The sensor can also be secured using standard cable ties (not provided).

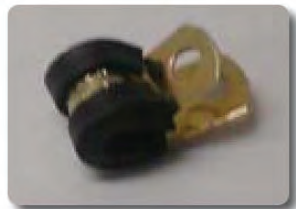

Sensor Clamp

Resistance Chart

The accuracy of the resistor can be verified using an Ohm meter. The chart below shows the resistance for various temperatures.

Temperature (°F)	Temperature (°C)	Resistance (Ohms)
-40	-40	336,450
-30	-34	234,170
-20	-29	165,210
-10	-23	118,060
0	-18	85,399
10	-12	62,493
20	-7	46,235
30	-1	34,565
40	4	26,100
50	10	19,899
60	16	15,311
70	21	11,883
80	27	9,299
90	32	7,334
100	38	5,828
110	43	4,664
120	49	3,758
130	54	3,048
140	60	2,488
150	66	2,042
160	71	1,686
170	77	1,400
180	82	1,169
190	88	981
200	93	827

General Purpose Temperature Sensor

P/N 501-1129

Overview

The 501-1129 is Copeland's general purpose temperature sensor. It is suited for a wide variety of applications. The temperature sensor has a 10K Ω thermistor. The thermistor is enclosed in a nickel-plated brass shell with epoxy. The sensor has a green 20' pigtail. The wire is a 22 AWG CL3X cord with 2 conductors. The cable is UL rated for 194°F (90°C). The sensor has been tested to maintain less than 0.72°F error between -40 and 248°F.



General Purpose Temperature Sensor

Installation

The sensor connections to the input point on the 16AI board are not polarity sensitive. The sensor can be wired to any available point on the 16AI board. Connect one lead to the 0V input, and connect the other lead to the SIG input. The sensor is connected as shown in the Sensor Wiring diagram. The sensor has a male mulex connector for use with a TD3 or Case Controller.

The dip switch for the 16AI input should be set to the ON position.

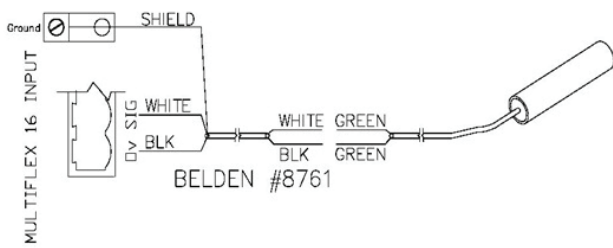

Sensor Wiring Diagram

The sensor includes a metal insulated clamp for securing the sensor. Mounting hardware is not included with the clamp. The sensor can also be secured using standard cable ties (not provided).



Sensor Clamp

Resistance Chart

The accuracy of the resistor can be verified using an Ohm meter. The chart below shows the resistance for various temperatures.

Temperature (°F)	Temperature (°C)	Resistance (Ohms)
-40	-40	336,450
-30	-34	234,170
-20	-29	165,210
-10	-23	118,060
0	-18	85,399
10	-12	62,493
20	-7	46,235
30	-1	34,565
40	4	26,100
50	10	19,899
60	16	15,311
70	21	11,883
80	27	9,299
90	32	7,334
100	38	5,828
110	43	4,664
120	49	3,758
130	54	3,048
140	60	2,488
150	66	2,042
160	71	1,686
170	77	1,400
180	82	1,169
190	88	981
200	93	827

General Purpose Temperature Sensor

P/N 501-1134

Overview

The 501-1134 is Copeland's general purpose temperature sensor. It is suited for a wide variety of applications. The temperature sensor has a 10K Ω thermistor, which is enclosed in a nickel-plated brass shell with epoxy. The sensor has a green 10' pigtail. The wire is a 22 AWG CL3X cord with 2 conductors. The cable is UL rated for 194°F (90°C). The sensor has been tested to maintain less than 0.72°F error between -40°F and 248°F.



General Purpose Temperature Sensor

Installation

The sensor connections to the input point on the 16AI board are not polarity sensitive. The sensor can be wired to any available point on the 16AI board. Connect one lead to the 0V input, and connect the other lead to the SIG input. The sensor is connected as shown in the Sensor Wiring diagram. The sensor has a male mulex connector for use with a TD3 or Case Controller.

The dip switch for the 16AI input should be set to the ON position.

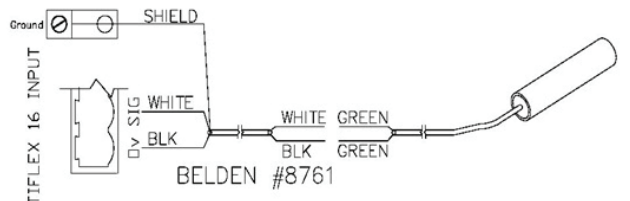

Sensor Wiring Diagram

The sensor includes a metal insulated clamp for securing the sensor. Mounting hardware is not included with the clamp. The sensor can also be secured using standard cable ties (not provided).

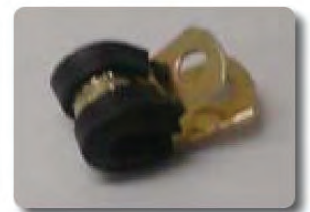

Sensor Clamp

Resistance Chart

The accuracy of the resistor can be verified using an Ohm meter. The chart below shows the resistance for various temperatures.

Temperature (°F)	Temperature (°C)	Resistance (Ohms)
-40	-40	336,450
-30	-34	234,170
-20	-29	165,210
-10	-23	118,060
0	-18	85,399
10	-12	62,493
20	-7	46,235
30	-1	34,565
40	4	26,100
50	10	19,899
60	16	15,311
70	21	11,883
80	27	9,299
90	32	7,334
100	38	5,828
110	43	4,664
120	49	3,758
130	54	3,048
140	60	2,488
150	66	2,042
160	71	1,686
170	77	1,400
180	82	1,169
190	88	981
200	93	827

Defrost Termination Temperature Sensor

P/N 501-1127

Overview

The 501-1127 is Copeland's defrost termination temperature sensor designed for measuring the coil temperature of an evaporator. The temperature sensor has a 10K Ω thermistor. The thermistor is enclosed in a nickel-plated brass shell with epoxy. The sensor has an orange 20' pigtail. The wire is 22 AWG CL3X cord with 2 conductors. The cable is UL rated for 194°F (90°C). The sensor has been tested to maintain less than 0.72°F error between -40°F and 248°F.



Defrost Termination Temperature Sensor

Resistance Chart

The accuracy of the resistor can be verified using an Ohm meter. The chart below shows the resistance for various temperatures.

Temperature (°F)	Temperature (°C)	Resistance (Ohms)
-40	-40	336,450
-30	-34	234,170
-20	-29	165,210
-10	-23	118,060
0	-18	85,399
10	-12	62,493
20	-7	46,235
30	-1	34,565
40	4	26,100
50	10	19,899
60	16	15,311
70	21	11,883
80	27	9,299
90	32	7,334
100	38	5,828
110	43	4,664
120	49	3,758
130	54	3,048
140	60	2,488
150	66	2,042
160	71	1,686
170	77	1,400
180	82	1,169
190	88	981
200	93	827

Installation

The sensor connections to the input point on the 16AI board are not polarity sensitive. The sensor can be wired to any available point on the 16AI board. Connect one lead to the 0V input, and connect the other lead to the SIG input. The sensor is connected as shown in the Sensor Wiring diagram. The sensor has a male mulex connector for use with a TD3 or Case Controller.

The dip switch for the 16AI input should be set to the ON position.

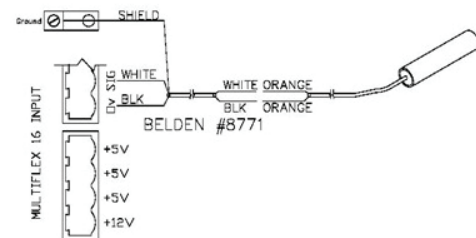

Sensor Wiring Diagram

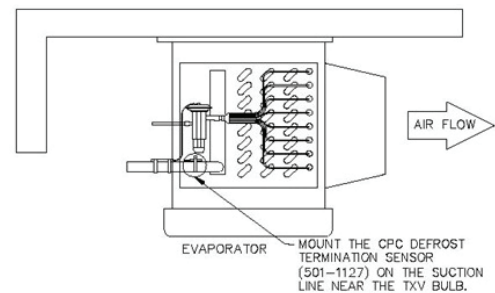

Sensor Mounting Diagram

Defrost Termination Temperature Sensor

P/N 501-1135

Overview

The 501-1135 is Copeland's defrost termination temperature sensor that is designed for measuring the coil temperature of an evaporator. The temperature sensor has a 10K Ω thermistor. The thermistor is enclosed in a nickel-plated brass shell with epoxy. The sensor has an orange 10' pigtail. The wire is a 22 AWG CL3X cord with 2 conductors. The cable is UL rated for 194°F (90°C). The sensor has been tested to maintain less than 0.72°F error between -40°F and 248°F



Defrost Termination Temperature Sensor

Installation

The sensor connections to the input point on the 16AI board are not polarity sensitive. The sensor can be wired to any available point on the 16AI board. Connect one lead to the 0V input, and connect the other lead to the SIG input. The sensor is connected as shown in the Sensor Wiring diagram. The sensor has a male mulex connector for use with a TD3 or Case Controller.

The dip switch for the 16AI input should be set to the ON position.

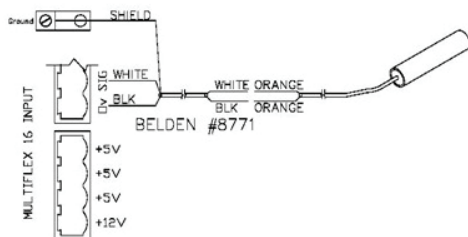

Sensor Wiring Diagram

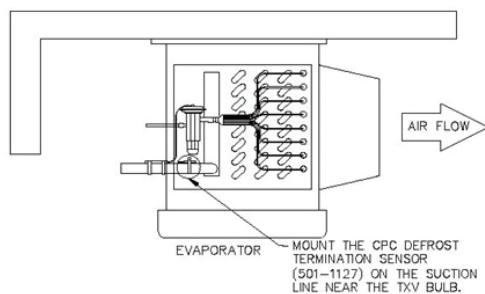

Sensor Mounting Diagram

Resistance Chart

The accuracy of the resistor can be verified using an Ohm meter. The chart below shows the resistance for various temperatures.

Temperature (°F)	Temperature (°C)	Resistance (Ohms)
-40	-40	336
-30	-34	234
-20	-29	165
-10	-23	118
0	-18	85
10	-12	62
20	-7	46
30	-1	34
40	4	26
50	10	19
60	16	15
70	21	11
80	27	9
90	32	7
100	38	5
110	43	4
120	49	3
130	54	3
140	60	2
150	66	2

Coil Outlet Temperature Sensor

P/N 501-1126

Overview

The 501-1126 is Copeland's coil outlet temperature sensor. It is designed for measuring the coil temperature of an evaporator. The temperature sensor has a 10K Ω thermistor that is enclosed in a nickel-plated brass shell with epoxy. The sensor has a red 20' pigtail. The wire is a 22 AWG CL3X cord with 2 conductors. The cable is UL rated for 194°F (90°C). The sensor has been tested to maintain less than 0.72°F error between -40°F and 248°F.



Coil Outlet Temperature Sensor

Installation

The sensor connections to the input point on the 16AI board are not polarity sensitive. The sensor can be wired to any available point on the 16AI board. Connect one lead to the 0V input, and connect the other lead to the SIG input. The sensor is connected as shown in the Sensor Wiring diagram. The sensor has a male mux connector for use with a TD3 or Case Controller.

The dip switch for the 16AI input should be set to the ON position.

The sensor includes a Panduit U119 cable tie. The sensor should be secured to the outlet of the evaporator coil using the cable tie provided with the sensor.

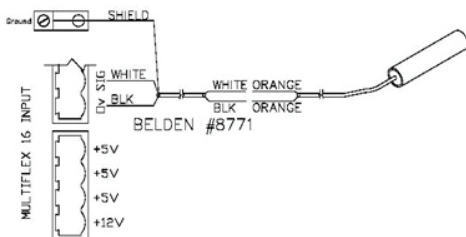

Sensor Wiring Diagram

Resistance Chart

The accuracy of the resistor can be verified using an Ohm meter. The chart below shows the resistance for various temperatures.

Temperature (°F)	Temperature (°C)	Resistance (Ohms)
-40	-40	336,450
-30	-34	234,170
-20	-29	165,210
-10	-23	118,060
0	-18	85,399
10	-12	62,493
20	-7	46,235
30	-1	34,565
40	4	26,100
50	10	19,899
60	16	15,311
70	21	11,883
80	27	9,299
90	32	7,334
100	38	5,828
110	43	4,664
120	49	3,758
130	54	3,048
140	60	2,488
150	66	2,042
160	71	1,686
170	77	1,400
180	82	1,169
190	88	981
200	93	827

Return Air Temperature Sensor

P/N 501-1128

Overview

The 501-1128 is Copeland's return air temperature sensor. It is suited for a wide variety of applications. The temperature sensor has a 10K Ω thermistor. The thermistor is enclosed in a nickel plated brass shell with epoxy. The sensor has a purple 20' pigtail. The wire is 22 AWG CL3X cord with 2 conductors. The cable is UL rated for 194°F (90°C). The sensor has been tested to maintain less than 0.72°F error between -40°F and 248°F.



Return Air Temperature Sensor

Installation

The sensor connections to the input point on the 16AI board are not polarity sensitive. The sensor can be wired to any available point on the 16AI board. Connect one lead to the 0V input, and connect the other lead to the SIG input. The sensor is connected as shown in the Sensor Wiring diagram. The sensor has a male mulex connector for use with a TD3 or Case Controller.

The dip switch for the 16AI input should be set to the ON position.

The sensor includes a metal insulated clamp for securing the sensor. Mounting hardware is not included with the clamp. The sensor can also be secured using standard cable ties (not provided).

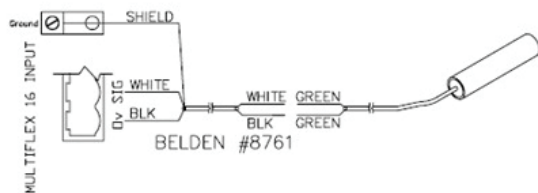

Sensor Wiring Diagram

Resistance Chart

The accuracy of the resistor can be verified using an Ohm meter. The chart below shows the resistance for various temperatures.

Temperature (°F)	Temperature (°C)	Resistance (Ohms)
-40	-40	336,450
-30	-34	234,170
-20	-29	165,210
-10	-23	118,060
0	-18	85,399
10	-12	62,493
20	-7	46,235
30	-1	34,565
40	4	26,100
50	10	19,899
60	16	15,311
70	21	11,883
80	27	9,299
90	32	7,334
100	38	5,828
110	43	4,664
120	49	3,758
130	54	3,048
140	60	2,488
150	66	2,042
160	71	1,686
170	77	1,400
180	82	1,169
190	88	981
200	93	827

20" Evaporator Temperature Sensor

P/N 501-6150

Overview

The 501-6150 is an evaporator temperature sensor designed for measuring the inlet air temperature of a walk-in freezer or cooler evaporator. The temperature sensor has a 10K Ω thermistor that is enclosed in a nickel-plated brass shell with epoxy. The sensor has a green 10' pigtail. The wire is a 22 AWG CL3X cord with 2 conductors. The cable is UL rated for 194° F (90°C). The sensor has been tested to maintain less than 0.72°F error between -40°F and 248°F.

Installation

The sensor connections to the input point on the 16AI board are not polarity sensitive. The sensor can be wired to any available point on the 16AI board. Connect one lead to the 0V input, and connect the other lead to the SIG input. The sensor is connected as shown in the Sensor Wiring diagram. The sensor has a male mulex connector for use with a TD3 or Case Controller.

The dip switch for the 16AI input should be set to the ON position.

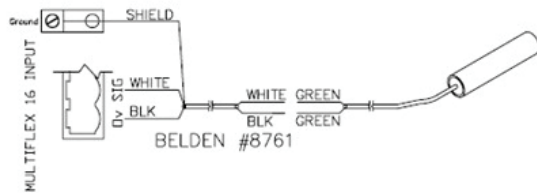

Sensor Wiring Diagram

The sensor shown in Figure 1 includes 2 metal plates and four 1.25" wood screws for mounting the sensor. Drill a 3/8" hole from the top of the cooler to insert the probe. The hole must be sealed with silicon after installing the sensor. The sensor should be installed in the center of the cooler as shown in the Sensor Mounting Location diagram.

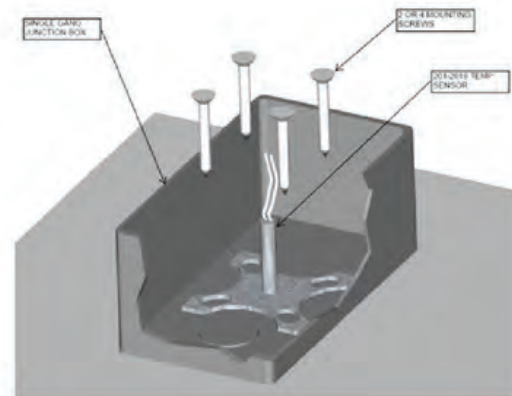
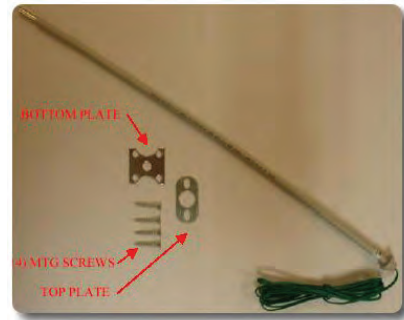

Sensor Mounting Diagram

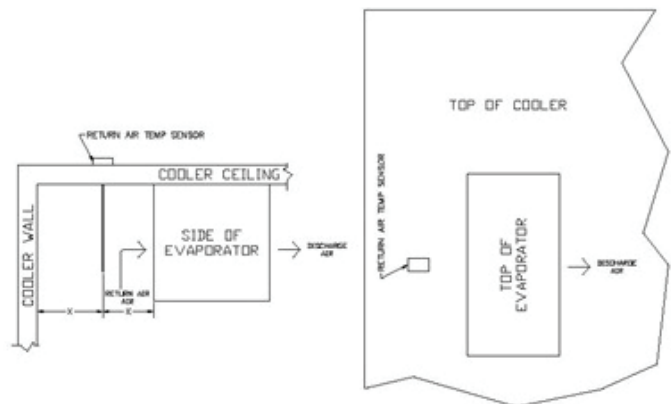

Sensor Mounting Location

Product Simulator Temperature Sensor

P/N 508-910x

Overview

The 508-910x is Copeland's product simulator temperature sensor. The sensor is available in two colors (White 508-9100, shown on the right, or Black-508-9101). The sensor is designed to comply with ANSI/ASHRAE 72-1983 Sec. 7. The temperature sensor has a 10K Ω thermistor that is enclosed in a stainless steel housing with FDA-EP2 epoxy. The sensor has a white or black 20' pigtail. The wire is NSF approved 22 AWG / 2 Conductor. The sensor has been tested to maintain less than 0.72°F error between -40°F and 180°F.



Product Simulator Temperature Sensor

Installation

The sensor connections to the input point on the 16AI board are not polarity sensitive. The sensor is connected as shown in the Sensor Wiring diagram. The sensor can be wired to any available point on the 16AI board. Connect one lead to the 0V input, and connect the other lead to the SIG input.

The dip switch for the 16AI input should be set to the ON position.

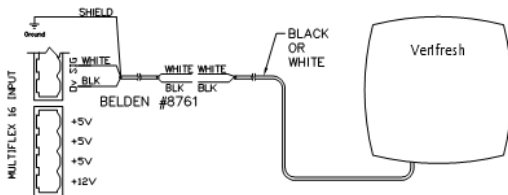

Sensor Wiring Diagram

The sensor includes a metal insulated clamp for securing the sensor. Mounting hardware is not included with the clamp. The sensor can also be secured using standard cable ties (not provided).

Resistance Chart

The accuracy of the resistor can be verified using an Ohm meter. The chart below shows the resistance for various temperatures.

Temperature (°F)	Temperature (°C)	Resistance (Ohms)
-40	-40	336,450
-30	-34	234,170
-20	-29	165,210
-10	-23	118,060
0	-18	85,399
10	-12	62,493
20	-7	46,235
30	-1	34,565
40	4	26,100
50	10	19,899
60	16	15,311
70	21	11,883
80	27	9,299
90	32	7,334
100	38	5,828
110	43	4,664
120	49	3,758
130	54	3,048
140	60	2,488
150	66	2,042
160	71	1,686
170	77	1,400
180	82	1,169

Wall-Mounted RH Sensor and RH/Temperature Sensor

P/N 203-5751, 203-5752, and 203-5756

Overview

Copeland specs a wall-mounted relative humidity (RH) sensor (P/N 203-5751) and combined RH and temperature sensor (P/N 203-5752 and 203-5756) for use in building control and anti-sweat control applications using Copeland input boards.

Specifications

Input Power	
Voltage	Class 2; 12 to 24 Vdc or 24 Vac
AC Voltage Tolerance	±10%
AC Frequency	50/60 Hz
Output	
Voltage Output	0 to 5 V or 0 to 10 V (jumper selectable)
Voltage Min. Load Resistance	5 kΩ
Voltage Min. Sinking Current	0.2 mA
Humidity	
RH Element	Digitally profiled thin-film capacitive, non-removable
Accuracy P/N 203-5752	3% (10 to 90% RH, 20 to 30°C)
Accuracy P/N 203-5756	2% (10 to 90% RH, 20 to 30°C)
Temperature Effect (Outside 20° to 30°C)	≤0.1% RH per °C
Response Time (to 90% change at 20°C)	110 sec
Annual Drift	≤1%
Output Scaling	0 to 100% RH
Temperature	
Sensor Type	Thermistor, 10k Ohm
Operating Environment	
Operating Temperature	0 to 50 °C (32 to 122 °F)
Operating Humidity	0 to 100% RH non-condensing (Unit will recover from saturation)
Housing	
Material	ABS plastic with UL V-0 5VB Flame Class
Mounting Holes	US and European junction box
Agency Approval	
	<p>*The CE mark indicates RoHS2 compliance. Please refer to the CE Declaration of Conformity for additional details.</p> <p>EMC Conformance: Low Voltage Directive 2014/35/EU and EMC Directive 2014/30/EU.</p>



Mounting

1. Mount the backplate on the wall in an appropriate location with the "Install This End Up" label positioned in the upper right corner.
2. Wire the unit as shown (see Wiring section).
3. Attach the front plate.

Wiring

1. Use Belden #8771 shielded three-conductor cable or equivalent.
2. Connect the RED, BLACK, and WHITE wires to the screw terminals the sensor's connector as shown in the Sensor Wiring diagram. Clip the SHIELD wire.
3. Connect the SHIELD and BLACK wires to the 0V terminal of the input board (under INPUT 1). Connect the WHITE wire to the SIG terminal of the input board.
4. Connect the RED wire to the +12V power terminal on the input board.

- Locate the input dip switch for the sensor point, and set to the OFF position (LEFT for MultiFlex, DOWN for 16AI). Refer to the input board's user manual for locations of the input dip switches.

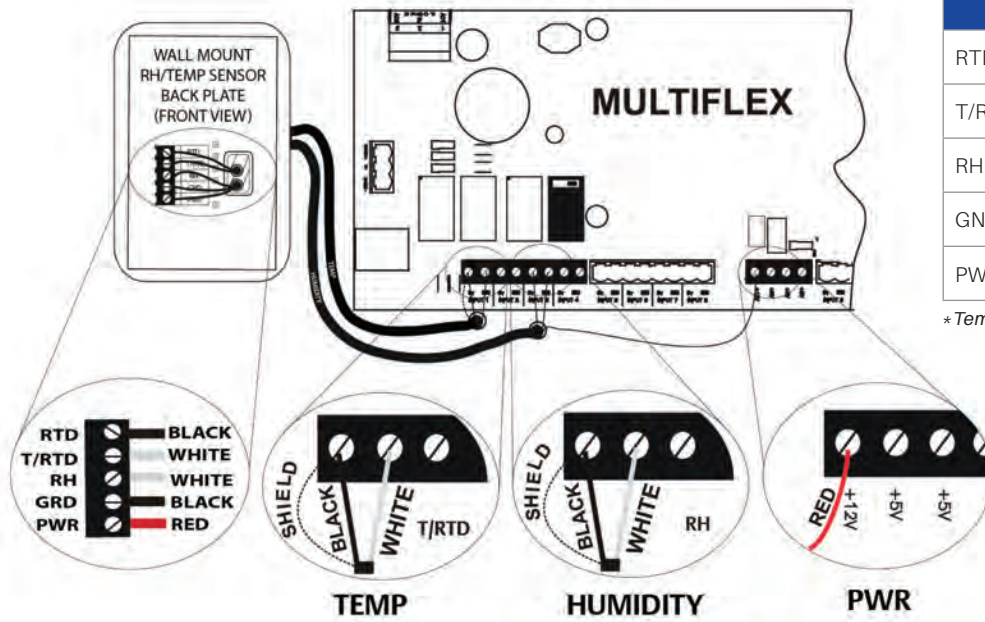

Legend		
RTD		RTD*
T/RTD		RTD/Temperature*
RH		Humidity
GND		GRND (DC- or AC1 and Output Common)
PWR		POWER (DC+ or AC2)

*Temperature models only

Sensor and Input Board Wiring

Operations

Copeland wall-mounted humidity sensors measure the levels of RH and temperature (if equipped) in the air inside a room. To maintain accurate functionality, keep all pickup vents clear and free of dust, debris, etc.

Dimensions

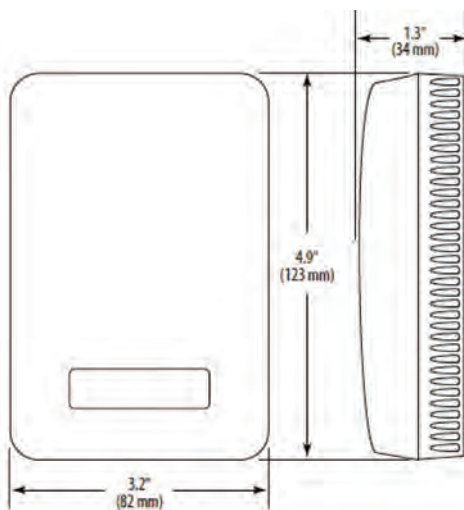

Installation

- Remove the cover by pressing the tab on the bottom of the sensor while pulling outward on the bottom edge of the cover.



- Position the sensor vertically on the wall, 4 . feet (1.5 m) above the floor. Place so that the "Install This End Up" statement on the board is in the upper right corner.

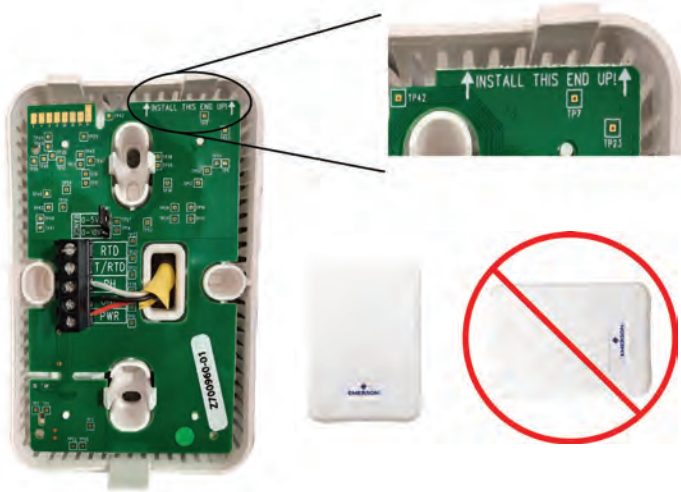

- Mount the backplate onto the wall using the screws provided.

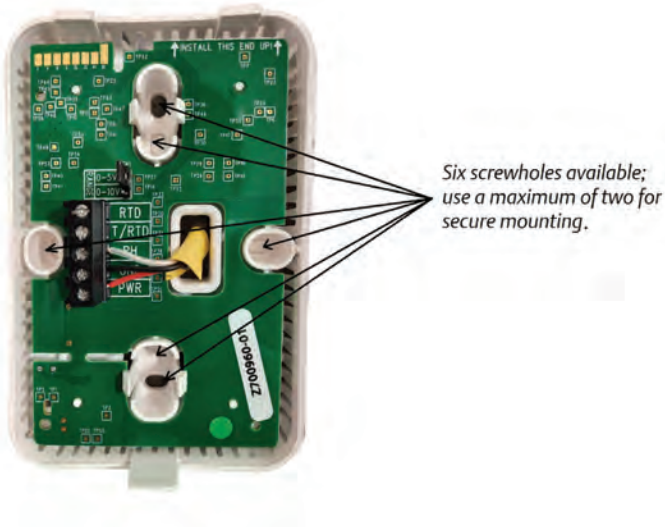

- Wire the backplate.

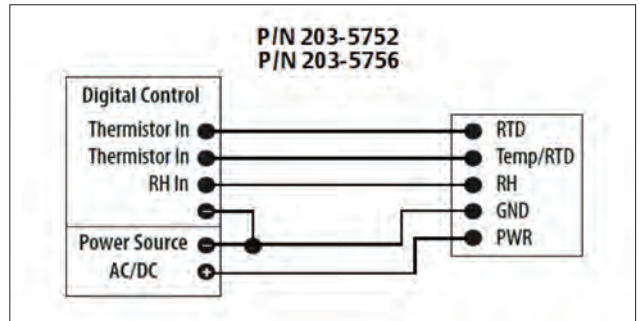
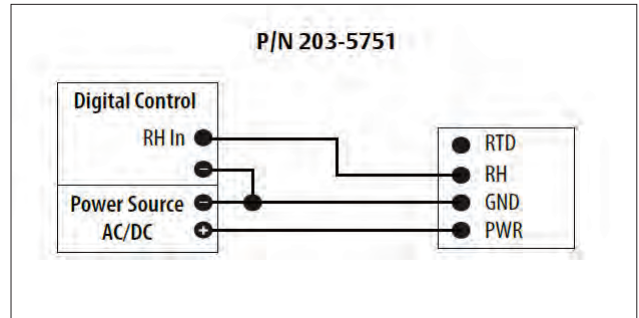

- Install the cover and snap into place.



Indoor Humidity Sensor

P/N 203-5753

Installation

The connections of the indoor humidity sensor to the input point on the 16AI board are polarity sensitive. The sensor is connected as shown in the Sensor Wiring Diagram. The sensor can be wired to any available point on the 16AI board. Connect the wires as indicated:

1. Connect PWR to +12VDC on 16AI
2. Connect OUT to SIG on 16AI
3. Connect COM to 0V on 16AI

The dip switch for the 16AI input should be set to the OFF position.

The sensor does not include any mounting hardware. The sensor can be secured directly to a single electrical box or to a wall using appropriate wall anchors.

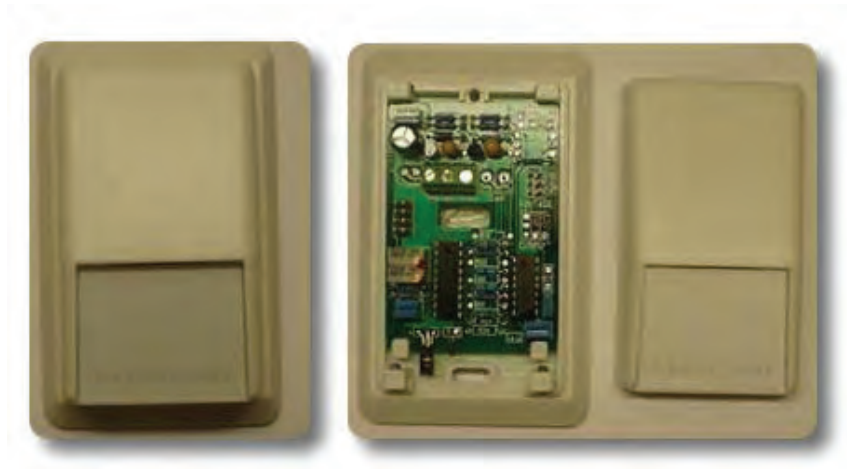

This sensor (pictured above) is manufactured by Greystone Energy Systems Inc. and is a registered trademark of the company.

Outdoor Humidity Sensor

P/N 203-5754

Installation

The connections of the outdoor humidity sensor to the input point on the 16AI board are polarity sensitive. The sensor is connected as shown below in the Sensor Wiring Diagram. The sensor can be wired to any available point on the 16AI board. Connect the wires as indicated:

1. Connect PWR to +12VDC on 16AI
2. Connect OUT to SIG on 16AI
3. Connect COM to 0V on 16AI

The dip switch for the 16AI input should be set to the OFF position. The sensor does not include any mounting hardware.

The sensor can be secured directly to any solid surface using the mounting tabs. The sensor can also be mounted on the top of conduit, if a knockout is added to the bottom of the enclosure.



This sensor (pictured above) is manufactured by Greystone Energy Systems, Inc. and is a registered trademark of that company

Duct-Mounted Humidity Sensor

P/N 203-5771

Overview

Copeland specs a duct-mounted relative humidity (RH) sensor with a 0-5VDC output for use in building control and anti-sweat control applications using Copeland input boards

Specification

Sensing Element	Digitally profiled thin-film capacitive
Accuracy	±2% RH over the range 20%-90% RH
Stability	±1% @ 20°C (68°F) annually for 2 years
Operating Humidity Range	0-100% RH
Temperature Coefficient	±0.03% RH /°C over 0-60°C (32-140°F)
Analog Output	0-5VDC; 3-wire, observe polarity
Scaling	0-100% RH
Input Power	12VDC
EMC Conformance	EN 50081-1, EN 50082-1, EN 61000-4-4, EN 61000-4-5, EN 61000-4-3, ENV 50204, EN 1000-4-6

Choosing a Mounting Location

Select a supply air duct that draws air from the area in which you wish to measure relative humidity. You may mount the sensor in any orientation provided the sensor element is in the air stream.

Mounting

1. Cut a small circular hole in the duct large enough for the sensor tube to fit through.
2. Bolt the sensor enclosure against the outside of the duct wall so that the sensor element fits through the hole and into the duct. The enclosure may be mounted horizontally (as shown in Humidity Sensor Exploded View diagram) or vertically. The screws should be tight enough for the foam gasket around the bottom of the sensor to form an airtight seal between the hole in the duct wall and the outside air.

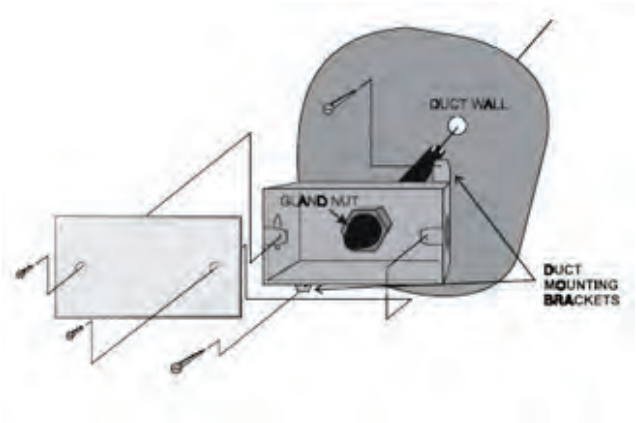

Humidity Sensor Exploded View

Wiring

NOTE: Do not clip or shorten the wires leading from the sensor tube! This will allow enough slack to remove the sensor element without having to dismount the enclosure.

1. Use Belden #8771 shielded three-conductor cable or equivalent.
2. Connect the RED, BLACK, and WHITE wires to the RED, BLACK, and GREEN wires from the sensor using the wire nuts supplied in the kit. Use the remaining wire nuts to cap and insulate the unused leads (BLUE, ORANGE, and YELLOW). Clip the shield (BARE) wire.
3. On the input board, connect the SHIELD and BLACK wires to the 0V terminal. Connect the WHITE wire to the SIG terminal of the input board.
4. Connect the RED wire to the +12V power terminal on the input board.
5. Locate the input dip switch for the sensor point, and set to the OFF position (LEFT for MultiFlex, DOWN for 16AI). Refer to the input board's user manual for locations of the input dip switches.

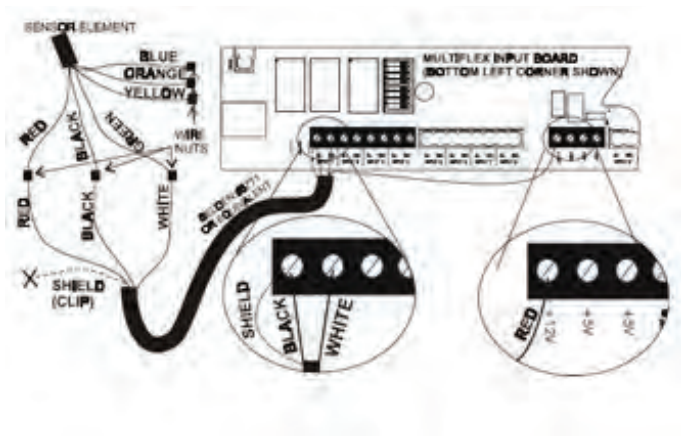

Sensor and Input Board Wiring

Finishing the Installation

Once the duct sensor is mounted and the sensor and board wiring is complete, check the gland nut that secures the sensor tube and tighten it if necessary (see Humidity Sensor Exploded View diagram for the location of the gland nut). Attach the cover plate (with the foam gasket included) to the sensor enclosure using the screws provided. Tighten all conduit connections, and cap all unused holes in the sensor enclosure.

Calibration and Replacement

The sensing element of the 203-5771 duct-mount RH sensor is pre-calibrated and requires no physical adjustment. If the sensor drifts over time, the sensor can be 'recalibrated' by replacing the pluggable sensing element. Contact Copeland to order replacement elements (P/N 203-5795).

To replace a sensor element, **pull the sensor's power connection from the input board.** Remove the cover plate of the enclosure, loosen the gland nut, and slide the sensor tube out through the enclosure until the sensor element is completely out of the duct and the tip of the tube can be accessed. Unscrew the top of the sensor tube to expose the pluggable RH sensor element.

Note the orientation of the sensor element before unplugging it and plug the new sensor element in using the same orientation. Replace the top when finished, reinsert the tube into the duct, tighten the gland nut, and restore power to the sensor. There is no other calibration method needed, and no adjustments are present in the unit.

NOTE: Do not expose the sensor element to the fumes of curing RTV silicone rubber. Doing so will damage the calibration of the element.

Carbon Dioxide Sensor

P/N 210-2000

Overview

Copeland's CO₂ sensor (P/N 210-2000) is a non-dispersive infrared analyzer designed for measuring environmental CO₂ concentration in ventilation systems and indoor spaces. Its measurement range of 0-2000 or 0-5000 ppm covers the range required to monitor compliance with ASHRAE and other ventilation efficiency standards.

An LCD display is available to provide local indication of CO₂ concentration and facilitate the setup and calibration process. An adjustable setpoint relay is available for direct control and alarm applications. Microprocessor-based digital electronics and a unique self-calibration algorithm improves long-term stability and accuracy.

Mounting

Before mounting, remove the door from the circuit board by pressing a screwdriver against the locking tab on the top of the enclosure. Pry the circuit board away from the mounting plate using a screwdriver inserted into the two tab slots on the top of the enclosure.

Choose a location for the sensor with good air circulation, away from ventilation inlets, doors, windows, or other points where fresh air enters the room. The sensor should be mounted at least 4-1/2 feet above the floor. The environment temperature must be within 32°—112°F (0°—50°C).

If wiring will be coming in through the mounting plate from the back, punch out openings in the mounting plate and use the plate as a template for locating holes. Mount the mounting plate against a wall or other flat surface by using the two mounting holes and the screws provided (use wall anchors for drywall installations).

NOTE: Sensors must be mounted vertically (straight up and down) to ensure proper readings.

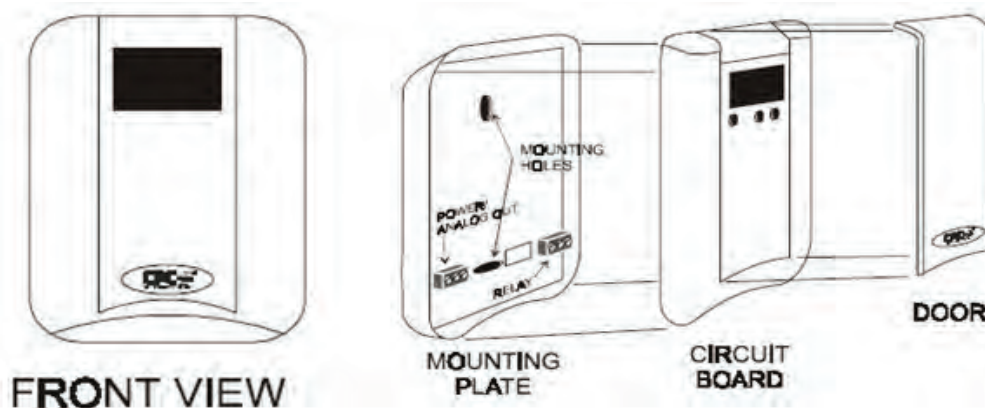

CO₂ Sensor (Exploded View)

Wiring

The mounting plate has two sets of three-terminal connectors. The connector on the left side of the mounting plate is where the sensor power and the signal-to-I/O-board connections are made. The connector on the right side is where connection to the on-board relay is made.

Power Wiring

The CO2 sensor requires 24VAC power from a non-center-tapped transformer. The sensor draws a maximum of 3VA power. Copeland recommends P/N 640- 0039, 10VA, 110VAC non-center-tapped Class 2 transformer.

Wire the transformer secondary to the connector on the left side of the mounting plate, as shown in the CO2 Sensor Wiring diagram.

Analog Output Wiring

The middle terminal of the connector on the left side of the mounting plate is the analog output that communicates the current CO2 concentration level to the site controller. This connector is typically connected to a point on an I/O board, such as a 16AI, 16AIE, or 8DO. Wire the middle (SIGNAL) terminal on the CO2 sensor to the **even numbered** terminal of the I/O board point. Wire the COMMON terminal on the CO2 sensor to the **odd numbered** terminal of the I/O board point. See the CO2 Sensor Wiring diagram.

Relay Wiring

The CO2 sensor has an on-board relay that changes state to indicate a CO2 level higher than a programmed set point. This relay can be used as a digital input on an input board point, or it can be used to directly activate or deactivate an alarm annunciator or a device that controls ventilation.

The connector on the right side of the mounting plate is a Form C connector for the CO2 sensor relay. Connect the input board point or device to the middle (COMMON) terminal of this connector, and either the N.C. or N.O. terminal, depending on whether you want the relay to be OPEN or CLOSED when the CO2 concentration is below the set point. See the CO2 Sensor Wiring diagram.

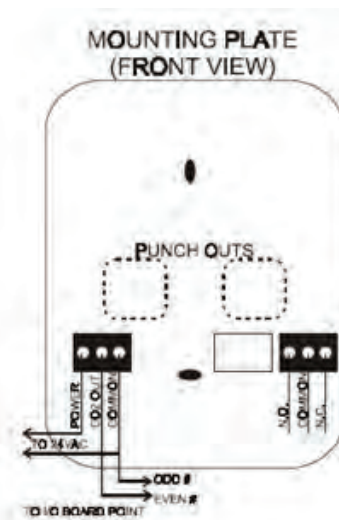

CO2 Sensor Wiring

Reassembly After Wiring

When you are finished wiring power and I/O to the connectors on the mounting plate, reconnect the circuit board to the mounting plate. Push the top end of the circuit board into the mounting plate so the two hooked tabs on the circuit board are underneath the tabs on the mounting plate. Then, gently press down on the bottom part of the circuit board until it snaps into place. See the CO2 Sensor Reassemble diagram.

If you have trouble pushing the circuit board in, check to see if the pins on the back of the circuit board are properly aligned with the power and relay connectors on the mounting plate. Also verify that there are no loose wires getting in the way.



CO2 Sensor Reassembly

Setting the Volts/Amps Switch

The front of the circuit board has a switch that controls whether the analog output sends a signal as voltage (V) or milliamps (mA). To work with I/O boards, this switch should be set to voltage (the DOWN position). Verify this switch is in the DOWN position before operating the sensor.

Setting Up the CO2 Sensor Software

Before operating the sensor, you must use the LCD display and the three buttons on the front of the circuit board to set the sensor's operating parameters.

The CO2 Sensor Keys and Screen diagram below shows the keys on the circuit board and the setup screens. Use the ENTER key to cycle through the setup screens, and the + and - keys to adjust parameter values.

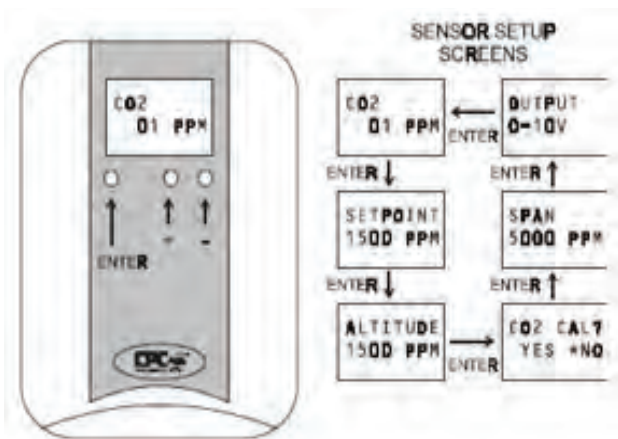

CO2 Sensor Keys and Screens

Setpoint

If you are using the CO2 sensor's relay for alarming or control, use the + and - keys to adjust the value of the set point. When the CO2 sensor's reading is above this set point, the relay will energize. Press **ENTER** to save the setpoint value.

Altitude

To properly measure CO2 concentrations, you must specify the approximate altitude of the site. Use the + and - keys to select the number of feet above sea level closest to the site's altitude. Press **ENTER** to save the altitude value.

CO2 Calibration

WARNING! Calibrating the CO2 sensor requires a gas calibration kit. **DO NOT** perform a calibration without this kit, or else the sensor will give erroneous readings.

All CO2 sensors are shipped pre-calibrated, and will only require calibration once every five years to ensure proper readings. Calibration requires a special gas kit available from Copeland. Follow the instructions that come with this kit to calibrate the sensor. Otherwise, press **ENTER** to bypass this screen and continue setup.

Span

The Span parameter determines whether you want to measure concentrations between 0-2000 ppm and 0-5000 ppm. If set to 2000 ppm, the sensor's analog output signal will be scaled properly so that the highest output voltage corresponds to 2000 ppm. Likewise, if set to 5000 ppm, the highest output voltage will signify 5000 ppm. Press **ENTER** to save settings.

Output

The Output parameter determines whether you want the analog output voltage to vary from 0- 5VDC or from 0-10 VDC. This parameter must be set to 0-5VDC if the analog output is connected to an I/O board's input point. Press **ENTER** to save settings.

Replacing the Door

Once all programming and wiring is done, the sensor is ready for operation. Snap the door on to the front of the circuit board to complete installation. The sensor comes equipped with two doors: one with a window that allows the screen to be shown, and one with no window that covers the screen. Choose whichever door is appropriate for your site.

Setting Up the Sensor Type in Einstein and REFLECS Controllers

The analog output of the CO2 sensor is a linear 0-5VDC signal, with 0V representing a concentration of 0 ppm, and 5V representing the maximum concentration level (either 2000 ppm or 5000 ppm, depending on the value of the Span parameter you chose when setting up the sensor).

In order for Einstein and the REFLECS line of controllers (RMCC, BEC, or BCU) to read the signal from the CO₂ sensor, it must be set up under Sensor Control (for REFLECS) or the Analog Input Setup Screen (for Einstein) as a **Linear** sensor. Refer to your controller's user manual for more information on the Linear sensor type and how to program its parameters.

When setting up the sensor in Einstein or REFLECS, you will need to include the following information:

Gain: The Gain is the number that will be multiplied with the number of volts coming from the CO₂ sensor's analog output to yield the concentration value. If the sensor's Span is set to 5000 ppm, use a Gain value of 1000. If the Span is set to 2000 ppm, use a Gain value of 400.

Offset: Because all calibration is handled by the sensor itself, the CO₂ sensor's offset should be set to zero.

Carbon Dioxide Sensor

P/N 510-2001

Overview

The 510-2001 is a carbon dioxide (CO₂) sensor designed to detect carbon dioxide levels in a building environment. It can measure CO₂ values between 0 and 10,000 PPM. The default scale for the sensor is 0 to 2,000 PPM. Note that this sensor was previously listed as P/N 210-2001. For ordering, use P/N 510-2001.

Installation

WARNING! Make sure the sensor is turned off before installing to avoid physical injury or damage to the sensor.

1. Detach the front enclosure of the sensor from the rear section (the rear section served as the sensor mounting plate).
2. Using the screws provided in the sensor package, secure the mounting plate to a solid wall or junction box.
3. Wire connections as directed (See Sensor Wiring Diagram).
4. Re-attach the front enclosure to the mounting plate by snapping it into the position and securing with the screw provided.



Carbon Dioxide Sensor

This sensor (pictured above) is manufactured by the General Electric Company (GE) and is a registered trademark of that company.

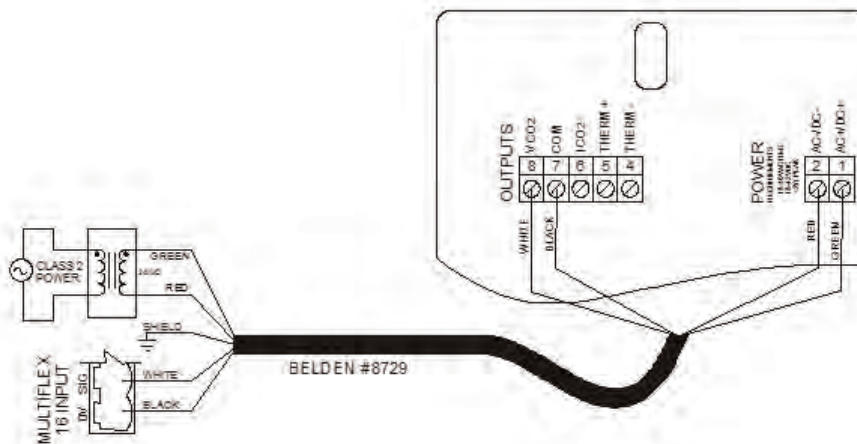

Sensor Wiring Diagram

E2 Input Setup

1. Press **LogInOut** and log in to the E2 with Level 4 access.
2. Press **All** + **I** to view the INPUT STATUS screen.
3. Use the arrow keys to highlight the correct board and point for the carbon dioxide sensor.
4. Press **F1** **i** to create an analog input.
5. Type in the desired name for the point in the **Point Name** field.
6. Use the arrow keys to highlight the Sensor Type field and press **F4** to change the sensor type to **Linear**.
7. Use the arrow keys to highlight the **Select Eng. Units** field and press **F4** to change the units to **PPM**.
8. Use the arrow keys to highlight the **HighEnd Point** field and change the value to **10**.
9. Use the arrow keys to highlight the **High Eng. Units** field and change the value to match the maximum scale for the sensor. The default value is 2000.
10. Press **Enter**  to accept the sensor input. The values to change on the analog input screen are circled in the Analog Input Screen graphic.

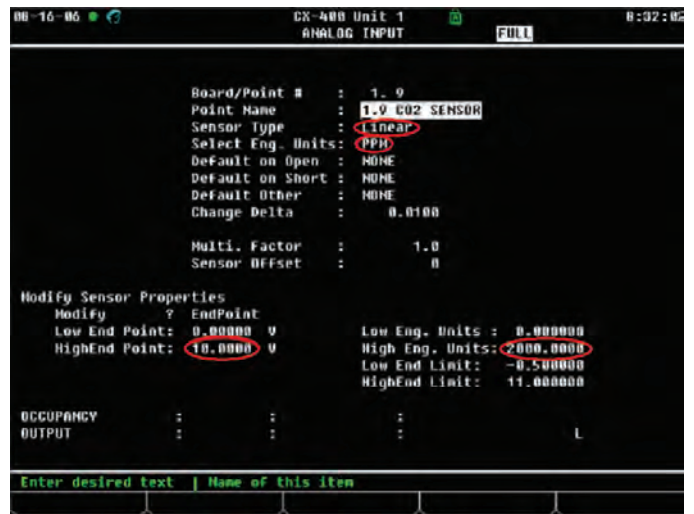

Analog Input Screen

Wall-Mount Dewpoint Sensor

P/N 210-2011

Overview

The Wall-Mount Dewpoint Probe (P/N 210-2011) measures dewpoint for indoor applications such as anti-sweat heater control and HVAC dehumidification. The probe's linear 0-5VDC output makes the probe compatible with the E2 site controller and all legacy CPC site control products that use MultiFlex and 16AI input boards.



Wall Mount Dewpoint Probe Sensor

The Vaisala dewpoint sensor is manufactured by Vaisala and is a registered trademark of that company.

Specifications

Property	Description/Value
Operating Temperature	-5°C to +55°C (+23°F to +131°F)
Storage Temperature	-20°C to +60°C (-4°F to +140°F)
Supply Voltage	18-35VDC or 24VAC
Current Consumption	12mA (maximum with relay 25mA)
Relative Humidity Range	0-90% RH, 90-100% RH
Accuracy	+/-1.7% RH, +/-2.5% RH
Output Voltage	2 x 0-5v or 2 x 0-10v
External Load	10k Ω min.

May be powered with MultiFlex or 16AI, 12 VDC output, if optional relay is not used.

Mounting

Mount the dewpoint probe enclosure against a flat surface (such as a wall or riser) or junction box. Remove the front cover, and remove the two screws that attach the sensor's circuit board to the rear mounting plate (See Circuit Board diagram). Attach the mounting plate to the mounting surface (See Enclosure Dimensions and Mounting Plate diagram), then reattach the circuit board and snap the cover back in place.

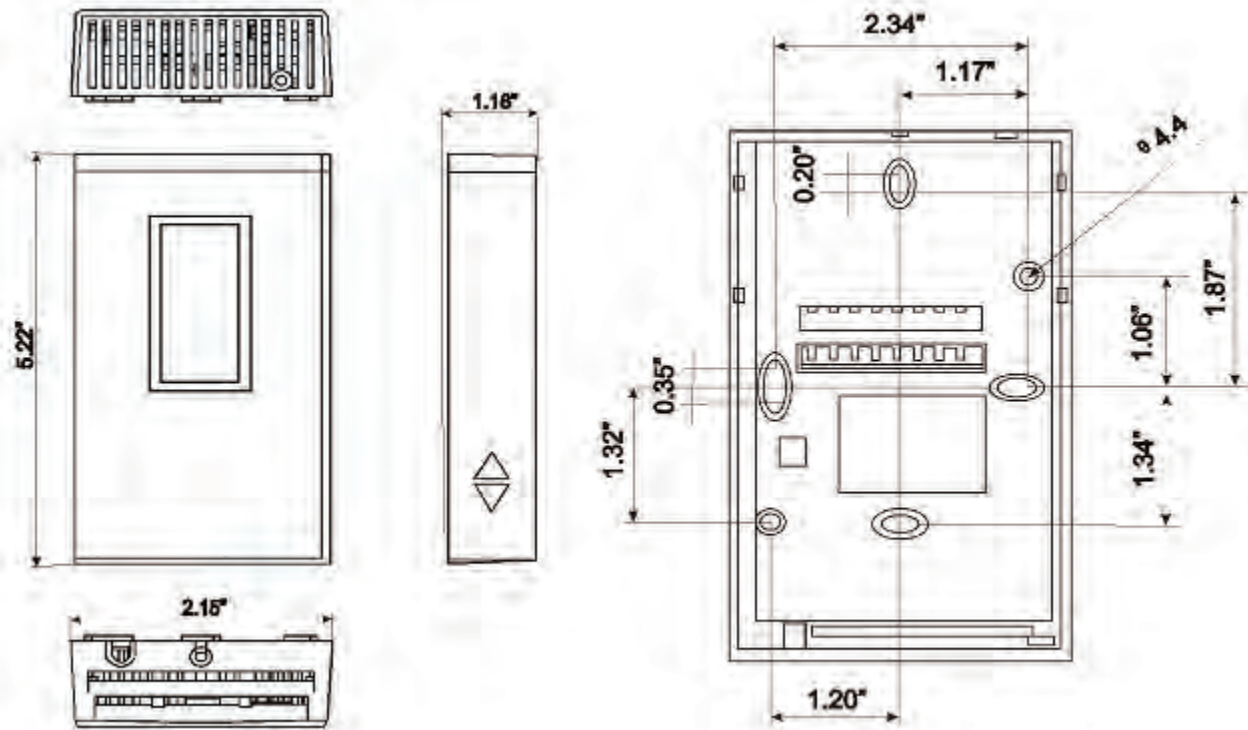

Enclosure Dimensions and Mounting Plate

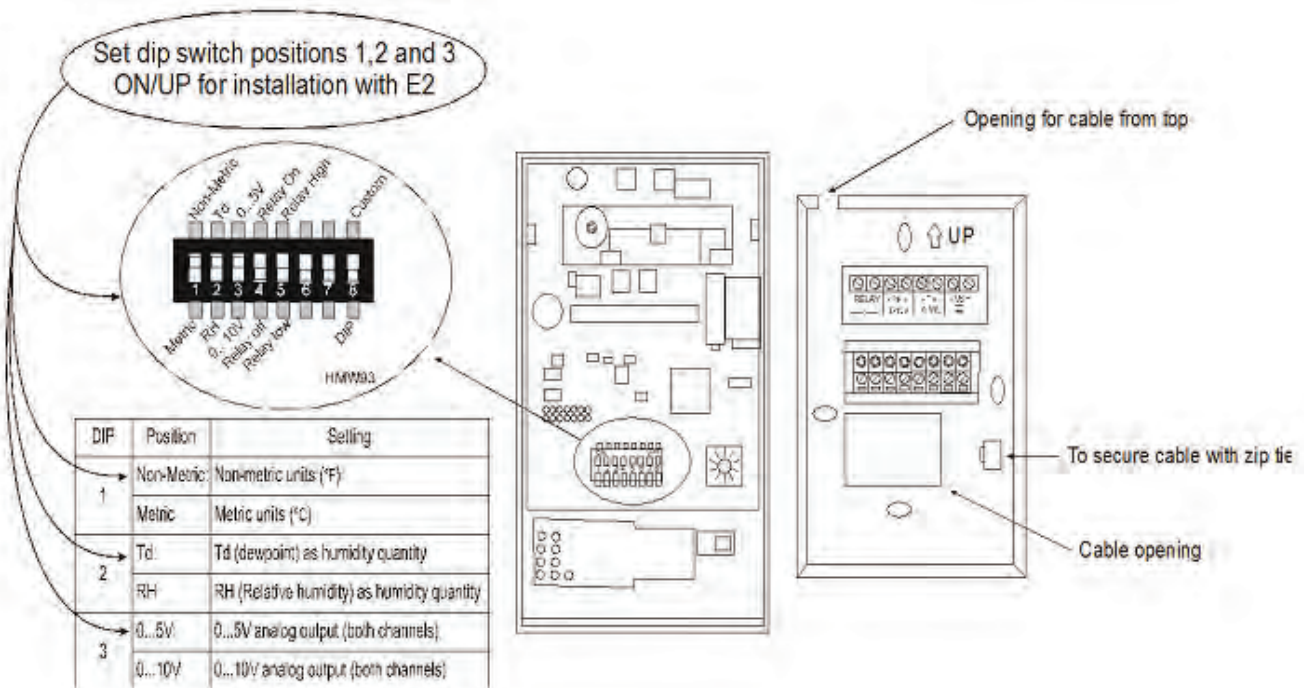

Circuit Board

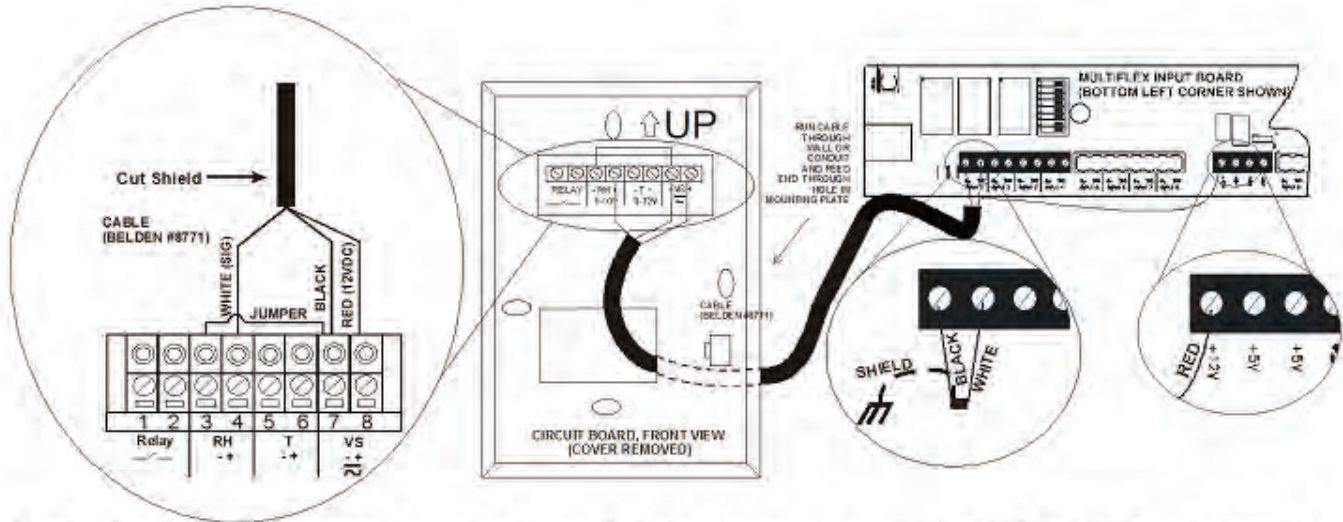

Note: To use the Relay, power must be supplied by a separate isolated 24VDC/24VAC transformer.

Dewpoint Probe Wiring

Power and Input Wiring

To wire the dewpoint probe to a MultiFlex or 16AI input point, use Belden #8771 three-conductor shielded 22AWG wire (or equivalent). The Dewpoint Probe Wiring diagram shows the connection point on the Dewpoint Probe and where to connect the wires to the probe as well as the MultiFlex input point. The sensor is powered by the +12VDC power supply terminal on the MultiFlex or 16AI input boards. Connect the SHIELD wire on the MultiFlex end of the cable to a separate earth ground near the board.

The input type dip switch on the MultiFlex or 16AI input board must be set to the DOWN position. Input type dip switches for points #1 through #8 are located on switch bank S1, while points #9 through #16 are located on switch bank S2.

Dewpoint dip switch setting for installation with E2.

1. Non-metric for Deg. F.
2. Td - dewpoint - for dewpoint linear output on RH terminals.
3. 0-5V - 0 to 5V linear output for Multiflex inputs.



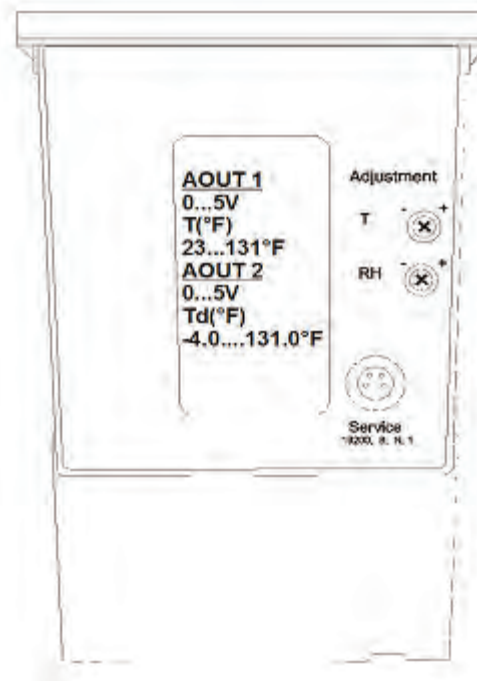



NOTE: The linear ranges on the label on the side of the dewpoint probe are for reading temperature and humidity, not for reading dewpoint. The dewpoint probe linear end points are displayed momentarily on power up if the dip switch position 2 is set to the dewpoint (Td) position. Td (-4 - 131°F) or (-20 - 55°C).



Dewpoint Sensor

E2 Input Setup

NOTE: Do NOT set up this probe with a sensor type of "Dewpoint"; this setting only works for old-style Dewpoint Probes (P/N 203-1902). This probe must be set up with a sensor type of "Linear."

1. Log into the E2 and press    (Input Summary).
2. Highlight the input point the Dewpoint Probe is connected to, and press  (Setup).
3. When prompted to select the data type, press  (Analog).
4. In the Analog Input setup screen, enter the following information in the fields listed below:
 - **Name:** A description of the sensor's function and/or location (for example, INDOOR DEWPT).
 - **Sensor Type:** Linear
 - **Eng. Unit:** DF
 - **Low Eng Units:** 0.0
 - **High Eng Units:** 100
5. Press  to save changes and exit the Analog Input setup screen.

NOTE: If you are using Degrees C, set Eng. Unit: DC, Low Eng. Units: -20.0 and High Eng. Units: 55. On the dewpoint probe dip switch, set position 1 to the metric position.

Calibration

The dewpoint probe is factory calibrated and should not need to be recalibrated. If the dewpoint probe is out of calibration, DO NOT use the E2 input offsets. The calibration must be adjusted on the dewpoint probe itself.

If the dewpoint probe needs calibration:

- Power down the dewpoint probe.
- Set the dip switch position 2 to the humidity (RH) position. Then re-power the dewpoint probe.
- Determine if the temperature or humidity readings need calibration.
- Use the appropriate adjustment trimmer (T) for temperature adjustments and/or (RH) for humidity adjustments (refer to Dewpoint Sensor diagram).
- Power down the dewpoint probe.
- Return dip switch position 2 to the dewpoint (Td) position. Then re-power the dewpoint probe.

Outdoor Dewpoint Sensor

P/N 210-2010

Overview

The 210-2010 is a wall-mounted dewpoint sensor that is suitable for indoor or outdoor installation. For indoor applications, sensor 210-2006 is recommended. The sensor calculates dewpoint using relative humidity and temperature values.

Installation

Open the sensor's front enclosure to expose the fastening holes inside the sensor. Attach the sensor's rear enclosure onto any solid surface (such as a wall) using four screws. When using the sensor in an outdoor application, a rain shield should be installed over the top of the sensor. Wire the sensor as shown in Sensor Wiring Diagram and Dimensions below. The sensor can be connected to any input board. The +12VDC output on the input board is used to power the sensor.

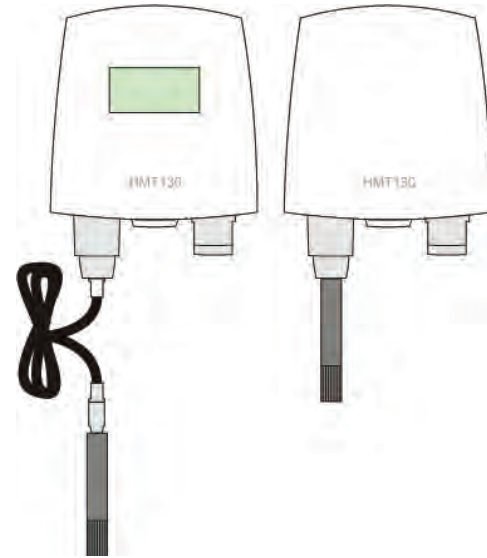

Outdoor Dewpoint Sensor

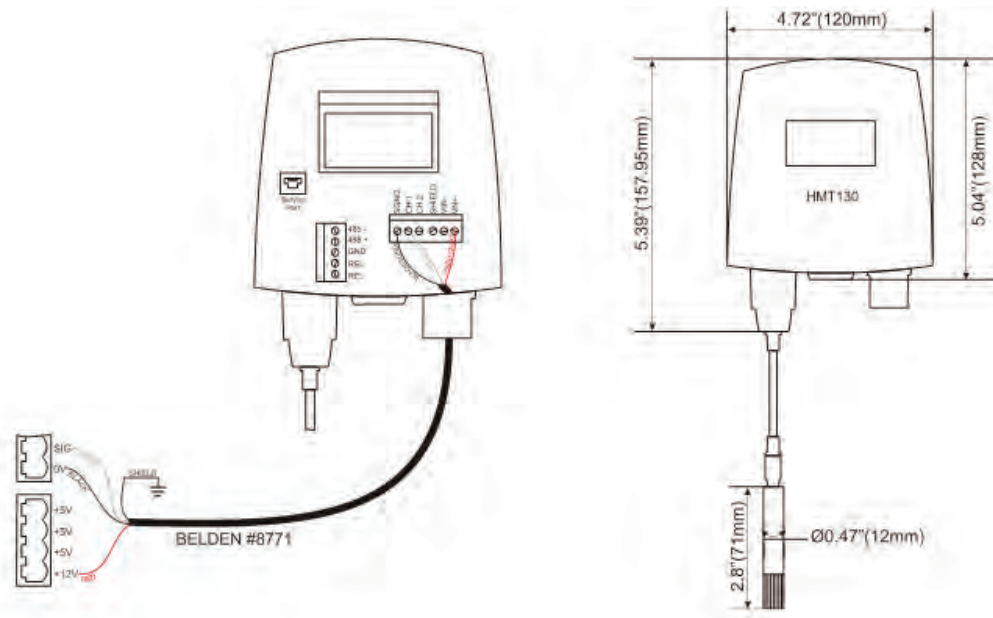

Sensor Wiring Diagram and Dimensions

Programming the Analog Input in the E2

1. After logging in to E2, press **Alt** + **I** to view the Input Status screen.
2. Use the cursor pad to highlight the application field for the correct board and point.
3. Press **Enter** **Enter** to setup the input.
4. Press **I** to select an analog input type.
5. Type in the desired name for the sensor and press **Enter**.
6. Set the Sensor Type to Linear.
7. Set the **Eng. Units** to **DF**.
8. Set the **Low Eng. Units** to **-4**.
9. Set the **High Eng. Units** to **176**.
10. Press **Enter** to accept the input.

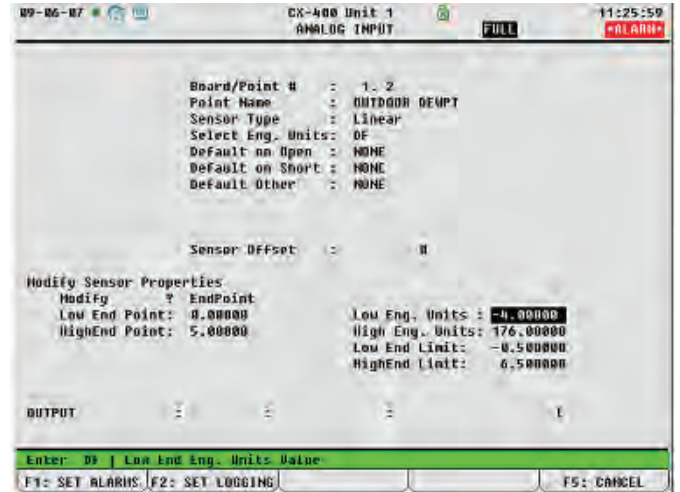

Analog Input Screen

Light Level Sensor

P/N 206-0002

Overview

The 206-0002 is a standard outdoor light level sensor. The light level sensor provides the controller with information that allows the controller to switch light ON or OFF. The specifications for the sensor are listed in the table below:

Operating Temperature	13° F to 140° F (-11° C to 60° C)
Sensor Type	Blue-enhanced Photo Diode
Input Voltage	12VDC from controller +5VDC
Output Voltage	0VDC at full darkness to 9VDC at full output
Operating Range	0 to 750 FC
Accuracy	+/- 1% at 70° F
Sensitivity	Approx. 1 V / 175 FC

*Connect the red wire to either the +12VDC or +5VDC terminal. The +12V terminal is preferred because of the higher resolution it provides. Note that on MultiFlex boards manufactured before April 2004 you must use the +5VDC terminal

Installation

The sensor connections to the input point on the 16AI board are not polarity sensitive. The sensor can be wired to any available point on the 16AI board and is connected as shown in the Sensor Wiring Diagram below.

1. Connect red and yellow lead to the SIG input.
2. Connect green to the 0V input.
3. Connect black to the +12 input.

The dip switch for the 16AI input should be set to the OFF position.

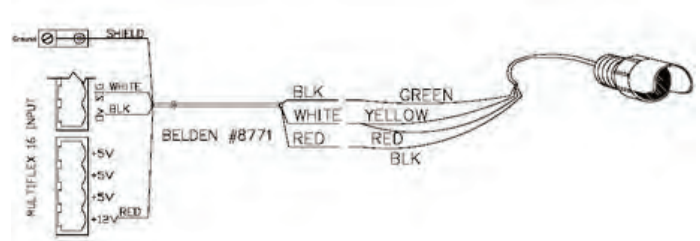

Sensor Wiring Diagram

NOTE: The sensor does not follow the standard Control wiring color code. The sensor must be wired as shown in the diagram.



Light Level Sensor

This sensor (pictured above) is manufactured by PLC-Multipoint, Inc. and is a registered trademark of that company

Single Channel PMAC

P/N 851-1010

Overview

The 851-1010 is a solid state single channel Pulse Modulating and Anti-Sweat Control (PMAC) unit designed to dramatically reduce the cost of operating anti-sweat heaters on medium or low temperature case doors. The PMAC pulses power to the door heaters based on environmental conditions. The PMAC cycles power to prevent condensation on the doors based on dew point and room temperature. The single channel PMAC is not a standalone unit. An Einstein or Einstein 2 controller determines the on/off duration of the PMAC using an Anti-Sweat application. The digital output from a MultiFlex board is used to operate the PMAC.



Single Channel PMAC

Specifications

Physical Dimension	5 11/16" L x 3" W x 2 1/2" T
AC input Voltage	120/240VAC single phase
AC Input Current	12A Circuit breaker (max)
Control Input	0-12VDC

Installation

The PMAC has four 3/16" diameter mounting holes. It can be mounted to any solid surface with appropriate mounting hardware (not provided). The unit can be mounted in any orientation. It must be connected as shown in the PMAC Wiring Diagram. Any available MultiFlex digital output (DO) point can be used for the 12VDC input on the PMAC. The PMAC 12VDC input is polarity sensitive. The 2 black #8 AWG leads are connected to the 120/240V hot lead for the door heater. Typically, the hot lead is black. The green #8 AWG lead must be connected to any suitable ACEG lead.

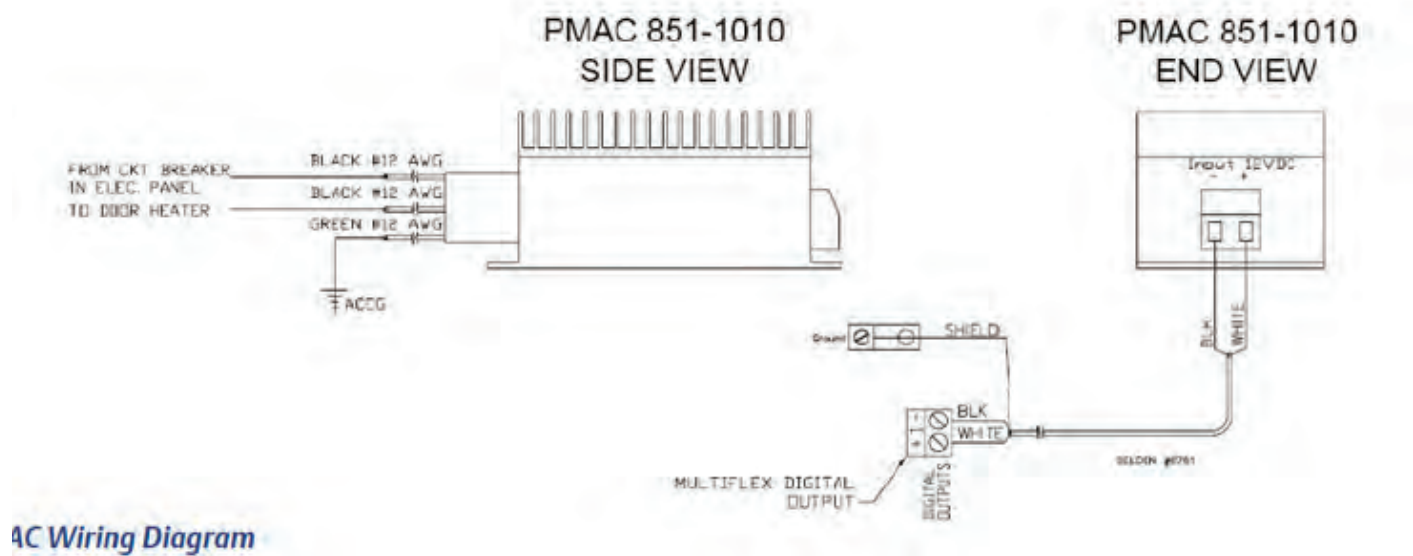

PMAC Wiring Diagram

E2 Programming

1. Press **Menu**, **6**, **1**, **F4**, **5**, **Enter**, **1**, **Y** to add an Anti-sweat application and enter the configuration screen.
2. On the **C1: General** screen:
 - Type in the Name for the Anti-sweat application in the **Name** field.
 - Typically, the controller calculates the dew point based on a humidity and temperature sensor. If a separate dew point sensor is used, change the **Use DewPt Snsr** value to **Yes**. This will change the **C3: inputs** tab from a temperature and humidity sensor to a single dew point sensor.
4. Press **F2** to view the **C3: Inputs** screen.
 - If the DewPt Snsr value on the **C1: General** screen is **No**, enter the **TEMPERATURE** and **REL HUMIDITY** sensors board and point location.
 - If the **DewPt Snsr** value on the **C1: General** screen is **Yes**, enter the **DEWPOINT IN** sensor board and point location.
5. Press **F2** to view the **C4: Outputs** screen.
 - Enter the **OUTPUT** board and point for the digital output (DO) to the PMAC 12V input.

NOTE: Do not change any other fields on the screen.

3. Press **F2** to view the **C2: Setpoints** screen.
 - Enter the **FULL ON DEWPT** value.
 - Enter the **FULL OFF DEWPT** value.

The value will vary depending on customer specifications and environmental conditions.

Typically, a **FULL ON DEWPT** value of **50-65** is used, and a **FULL OFF DEWPT** value of **20-25** is used.

Single Channel PMAC

P/N 851-1021

Overview

The 851-1021 is a solid-state single channel Pulse Modulating and Anti-sweat Control (PMAC) unit designed to dramatically reduce the cost of operating anti-sweat heaters on medium or low temperature case doors. The PMAC pulses power to the door heaters based on environmental conditions. The PMAC cycles power to prevent condensation on the doors based on dew point and room temperature. The single channel PMAC is not a standalone unit. An Einstein or Einstein 2 controller determines the on/off duration of the PMAC using an Anti-Sweat application. The digital output from a MultiFlex board is used to operate the PMAC.



Single Channel PMAC

Specifications

Physical Dimension	6 1/8"L x 2 7/8"W x 4 1/8"T
AC input Voltage	120/240VAC single phase
AC Input Current	20A Circuit breaker (max)
Control Input	0-12VDC

Installation

The PMAC has four 3/16" diameter mounting holes. It can be mounted to any solid surface with appropriate mounting hardware (not provided). The unit can be mounted in any orientation. It must be connected as shown in the PMAC Wiring Diagram. Any available MultiFlex digital output (DO) point can be used for the 12VDC input on the PMAC. The PMAC 12VDC input is polarity sensitive. The 2 black #8 AWG leads are connected to the 120/240V hot lead for the door heater. Typically, the hot lead is black. The green #8 AWG lead must be connected to any suitable ACEG lead.

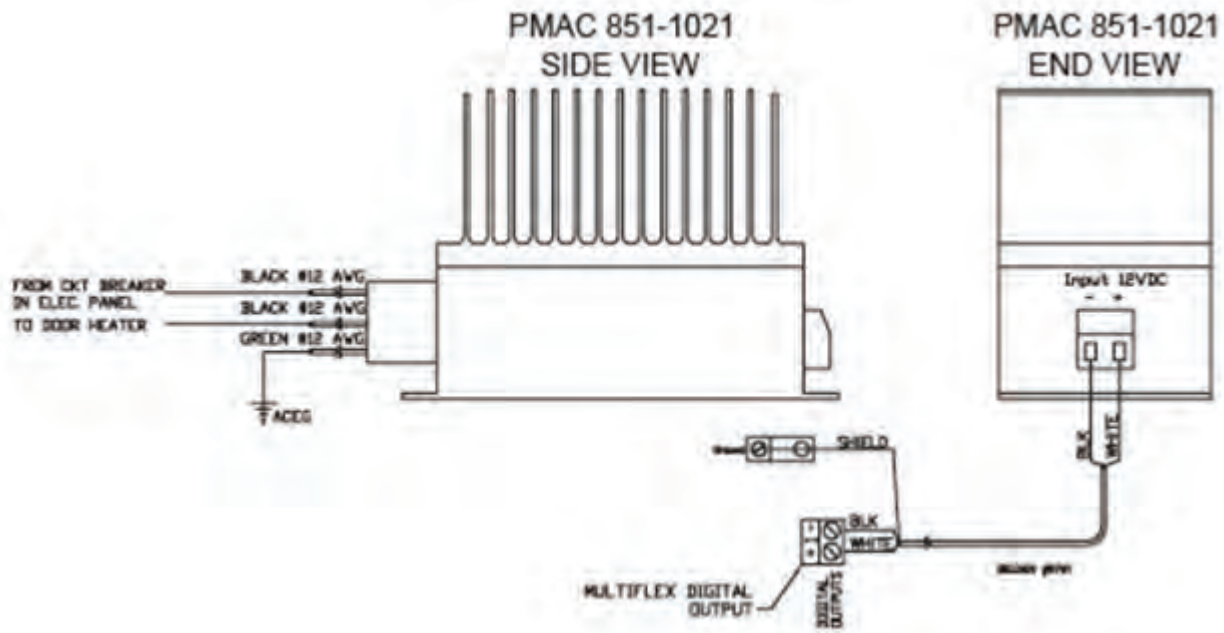

PMAC Wiring Diagram

E2 Programming

1. Press **Menu**, **8**, **1**, **F4**, **5**, **Enter**, **1**, **Y** to add an Anti-sweat application and enter the configuration screen.
2. On the **C1: General** screen:
 - Type in the Name for the Anti-sweat application in the **Name** field.
 - Typically, the controller calculates the dew point based on a humidity and temperature sensor. If a separate dew point sensor is used, change the Use **DewPt Snsr** value to **Yes**. This will change the **C3: inputs** tab from a temperature and humidity sensor to a single dew point sensor.
3. Press **F2** to view the **C2: Setpoints** screen.
 - Enter the **FULL ON DEWPT** value.
 - Enter the **FULL OFF DEWPT** value.
4. Press **F2** to view the **C3: Inputs** screen.
 - If the DewPt Snsr value on the **C1: General** screen is **No**, enter the **TEMPERATURE** and **REL HUMIDITY** sensors board and point location.
 - If the **DewPt Snsr** value on the **C1: General** screen is **Yes**, enter the **DEWPOINT IN** sensor board and point location.
5. Press **F2** to view the **C4: Outputs** screen.
 - Enter the **OUTPUT** board and point for the digital output (DO) to the PMAC 12V input.

NOTE: Do not change any other fields on the screen.

3. Press **F2** to view the **C2: Setpoints** screen.
 - Enter the **FULL ON DEWPT** value.
 - Enter the **FULL OFF DEWPT** value.

The value will vary depending on customer specifications and environmental conditions.

Typically, a **FULL ON DEWPT** value of **50-65** is used, and a **FULL OFF DEWPT** value of **20-25** is used.

Single Channel PMAC

P/N 851-1030

Overview

The 851-1030 is a solid-state single channel Pulse Modulating and Anti-sweat Control (PMAC) unit designed to dramatically reduce the cost of operating anti-sweat heaters on medium or low temperature case doors. The PMAC pulses power to the door heaters based on environmental conditions. The PMAC cycles power to prevent condensation on the doors based on dew point and room temperature. The single channel PMAC is not a standalone unit. An Einstein or Einstein 2 controller determines the ON/OFF duration of the PMAC using an anti-Sweat application. The digital output from a MultiFlex board is used to operate the PMAC.



Single Channel PMAC

Specifications

Physical Dimension	6 1/8"L x 2 7/8"W x 4 1/8"T
AC input Voltage	120/240VAC single phase
AC Input Current	30A Circuit breaker (max)
Control Input	0-12VDC

Installation

The PMAC has four 3/16" diameter mounting holes. It can be mounted to any solid surface with appropriate mounting hardware (not provided). The unit can be mounted in any orientation. It must be connected as shown in the PMAC Wiring Diagram. Any available MultiFlex digital output (DO) point can be used for the 12VDC input on the PMAC. The PMAC 12VDC input is polarity sensitive. The 2 black # 10 AWG leads are connected to the 120/240V hot lead for the door heater. Typically, the hot lead is black. The green # 10 AWG lead must be connected to any suitable ACEG lead.

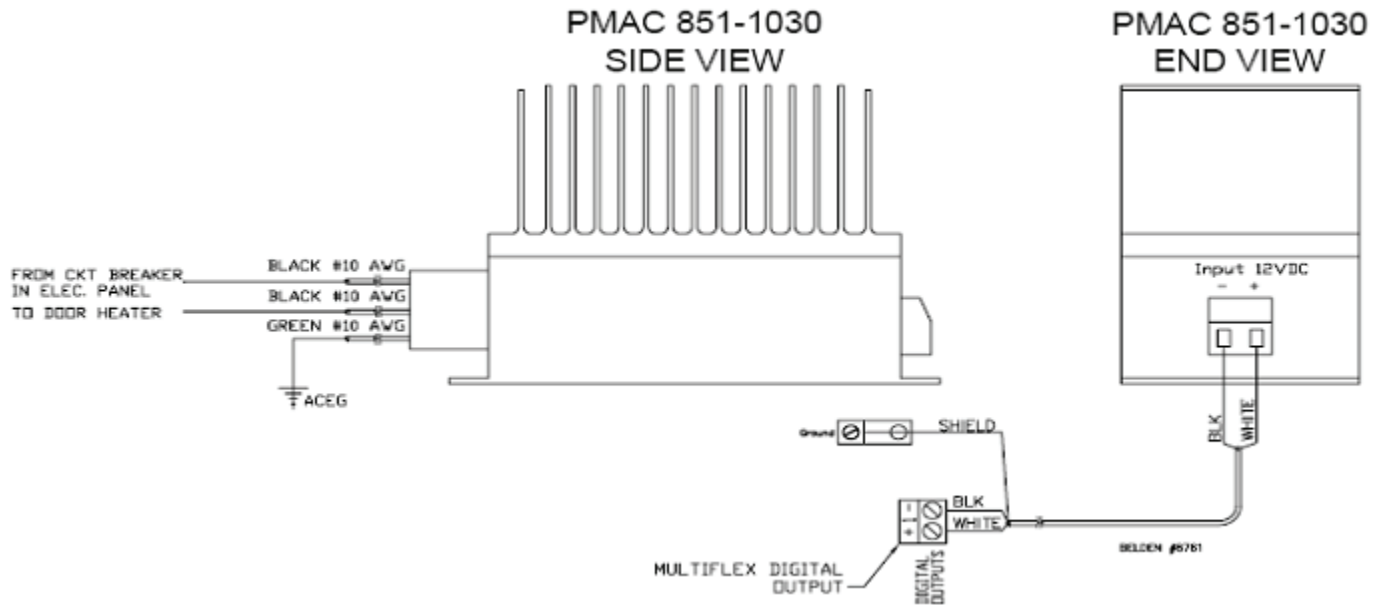

PMAC Wiring Diagram

E2 Programming

1. Press **Menu**, **8**, **1**, **F4**, **5**, **Enter**, **1**, **Y** to add an Anti-sweat application and enter the configuration screen.
2. On the **C1: General** screen:
 - Type in the Name for the Anti-sweat application in the **Name** field.
 - Typically, the controller calculates the dew point based on a humidity and temperature sensor. If a separate dew point sensor is used, change the Use **DewPt Snsr** value to **Yes**. This will change the **C3: inputs** tab from a temperature and humidity sensor to a single dew point sensor.
3. Press **F2** to view the **C2: Setpoints** screen.
 - Enter the **FULL ON DEWPT** value.
 - Enter the **FULL OFF DEWPT** value.
4. Press **F2** to view the **C3: Inputs** screen.
 - If the DewPt Snsr value on the **C1: General** screen is **No**, enter the **TEMPERATURE** and **REL HUMIDITY** sensors board and point location.
 - If the **DewPt Snsr** value on the **C1: General** screen is **Yes**, enter the **DEWPOINT IN** sensor board and point location.
5. Press **F2** to view the **C4: Outputs** screen.
 - Enter the **OUTPUT** board and point for the digital output (DO) to the PMAC 12V input.

NOTE: Do not change any other fields on the screen.

3. Press **F2** to view the **C2: Setpoints** screen.
 - Enter the **FULL ON DEWPT** value.
 - Enter the **FULL OFF DEWPT** value.

The value will vary depending on customer specifications and environmental conditions.

Typically, a **FULL ON DEWPT** value of **50-65** is used, and a **FULL OFF DEWPT** value of **20-25** is used.

Single Channel PMAC

P/N 851-1040

Overview

The 851-1040 is a solid state single channel Pulse Modulating and Anti-sweat Control (PMAC) unit designed to dramatically reduce the cost of operating anti-sweat heaters on medium or low temperature case doors. The PMAC pulses power to the door heaters based on environmental conditions. The PMAC cycles power to prevent condensation on the doors based on dew point and room temperature. The single channel PMAC is not a standalone unit. An Einstein or Einstein 2 controller determines the on/off duration of the PMAC using an Anti-sweat application. The digital output from a MultiFlex board is used to operate the PMAC.



Single Channel PMAC

Specifications

Physical Dimension	6 1/8" L x 2 7/8" W x 4 1/8" T
AC input Voltage	120/240VAC single phase
AC Input Current	40A Circuit breaker (max)
Control Input	0-12VDC

Installation

The PMAC has four 3/16" diameter mounting holes. It can be mounted to any solid surface with appropriate mounting hardware (not provided). The unit can be mounted in any orientation. It must be connected as shown in the PMAC Wiring Diagram. Any available MultiFlex digital output (DO) point can be used for the 12VDC input on the PMAC. The PMAC 12VDC input is polarity sensitive. The 2 black #8 AWG leads are connected to the 120/240V hot lead for the door heater. Typically, the hot lead is black. The green #8 AWG lead must be connected to any suitable ACEG lead.

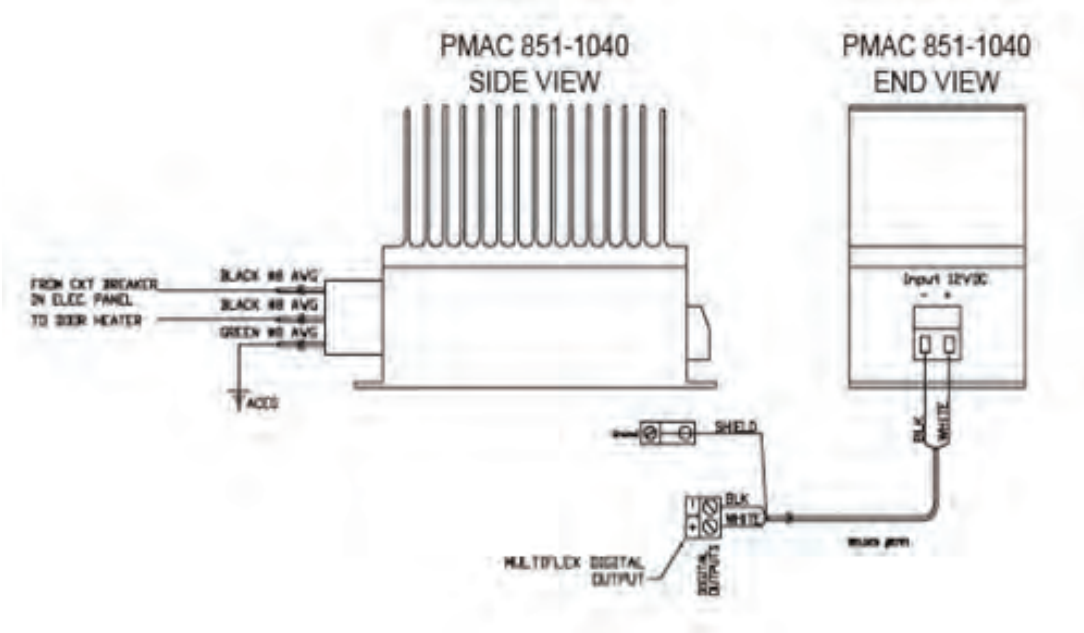

PMAC Wiring Diagram

E2 Programming

1. Press **Menu**, **6**, **1**, **F4**, **5**, **Enter**, **1**, **Y** to add an Anti-sweat application and enter the configuration screen.
2. On the **C1: General** screen:
 - Type in the Name for the Anti-sweat application in the **Name** field.
 - Typically, the controller calculates the dew point based on a humidity and temperature sensor. If a separate dew point sensor is used, change the Use **DewPt Snsr** value to **Yes**. This will change the **C3: inputs** tab from a temperature and humidity sensor to a single dew point sensor.
4. Press **F2** to view the **C3: Inputs** screen.
 - If the DewPt Snsr value on the **C1: General** screen is **No**, enter the **TEMPERATURE** and **REL HUMIDITY** sensors board and point location.
 - If the **DewPt Snsr** value on the **C1: General** screen is **Yes**, enter the **DEWPOINT IN** sensor board and point location.
5. Press **F2** to view the **C4: Outputs** screen.
 - Enter the **OUTPUT** board and point for the digital output (DO) to the PMAC 12V input.

NOTE: Do not change any other fields on the screen.

3. Press **F2** to view the **C2: Setpoints** screen.
 - Enter the **FULL ON DEWPT** value.
 - Enter the **FULL OFF DEWPT** value.

The value will vary depending on customer specifications and environmental conditions.

Typically, a **FULL ON DEWPT** value of **50-65** is used, and a **FULL OFF DEWPT** value of **20-25** is used.

Hand-Held Terminal

P/N 814-3110

Overview

The new Hand-Held Terminal (HHT) is a direct replacement for the previous generation HHT (P/N 811-3110), which has been discontinued. The new version has all of the features and benefits of the previous version.

The HHT is used by manufacturers and service technicians to diagnose and test several of Copeland's existing and legacy products. The HHT can be used on any Copeland product with an RJ-11 connector. The most common applications include:

- All MultiFlex I/O boards and the 8ROSMT
- All Gateway boards
- Stand-alone MultiFlex boards (RTU, RCB, PAK, CUB)
- CCB and CC-100 case controllers

The HHT does not require a separate power source. The unit is powered from the RJ-11 connector on the peripheral equipment. The 9V battery and 9-12VDC adapter connection are not used on this model. The HHT includes a standard male RJ-11 to male RJ-11 cable.

Specifications

Connector	Female RJ-11 plug
Display	Graphic LCD (128 x 64 pixels)
Power Requirements	None (9V battery optional)
Dimensions	3.9" Wide x 8.3" Tall x 1.6" Deep (approx.)
Operating Environment	-20°C to 50°C
Storage Environment	-40°C to 65°C
Approvals	UL/CSA, CE, FCC

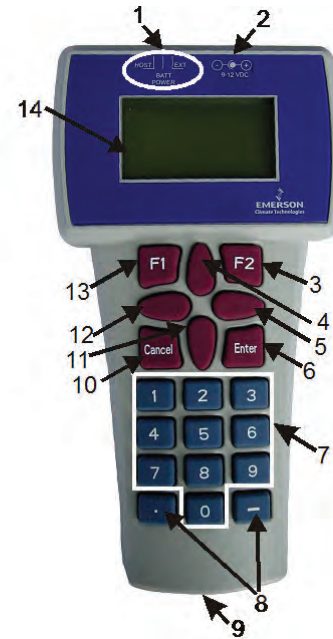

Legend			
1	The power switch determines if the HHT is in self-powered mode (BATT), ext power (EXT), or if powered from a target device (Host).	8	Scrolls list selections and scrolls through ASCII characters if in a text field.
2	External Power Connector (9-12 VDC)	9	RS-485 Connector
3	F2- Main Menu	10	Cancel - clears/erase text in editable field; cancels overrides.
4	Up Arrow - moves to previous screen, editable field, or top of screen.	11	Down Arrow - moves to next screen, editable field, end of screen, or advances.
5	Right Arrow - selects last editable field starting from bottom of screen; selects last editable field from bottom to top.	12	Left Arrow - selects first editable field from top of screen, and next editable field from top to bottom.
6	Enter - save into memory	13	F1 - Home Screen
7	Numeric keypad	14	LCD - Four lines of 16 characters.

Hand-Held Terminal

Light Dimming Module Kit

P/N 603-0400 and 603-0410

Overview

The Light Dimming Module is used to control light dimming ballast(s). The module is approximately 3" x 5" and uses a single 0-10VDC analog output from a MultiFlex board. The input and output voltages are listed in the below table:

Board Input (MultiFlex)	Board Output (Light Ballast) 1.2 Amp	Light Condition
0VDC	0VDC	Full Dim
10VDC	10VDC	Full Bright

Input and Output Voltages



Light Dimming Module Kit

The module has a proof output. The proof output is connected to a NC relay output. If proofing is used, the output should be connected to any available analog input on a MultiFlex board. The dip switch for the analog input should be ON.

For ordering information, refer to the table below:

Part Number	Description
603-0400	The module kit includes the dimming board, Snap-Track, signal isolator, connectors, 56VA transformer, and this instruction sheet.
603-0410	The module kit includes the dimming board, Snap-Track, connectors, 56VA transformer, and this instruction sheet. The 603-0410 module kit does not include the signal isolator.

Ordering Information

Installation

The Light Dimming Module can be installed in any orientation. The module includes a Snap-Track. The Snap-Track should be mounted in a standard enclosure. The module requires 12VAC. **Connecting the power input to the AC1 and AC2 side of a standard 24V transformer will damage the module.** A center-tap 24V transformer should be used to power the module as shown in the wiring diagram (Typical Light Dimming Module Wiring Diagram).

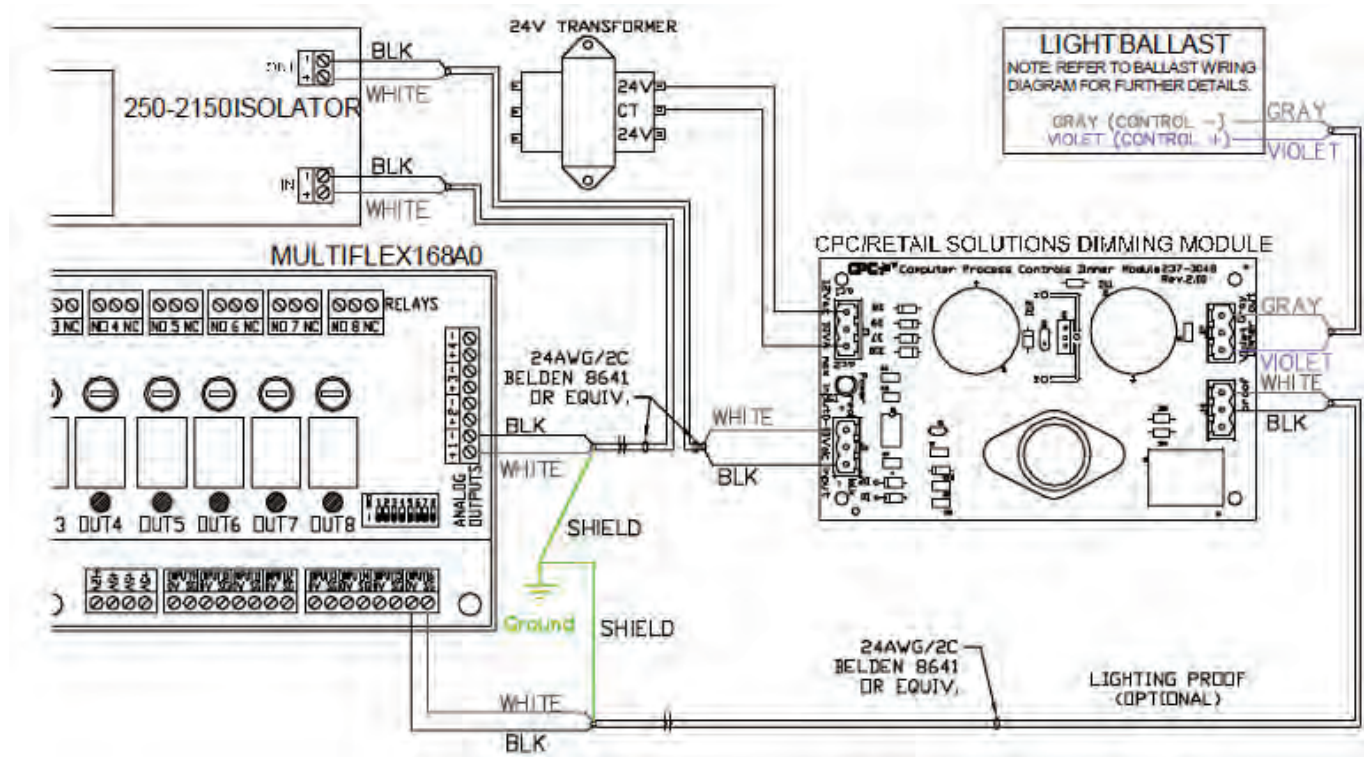

Typical Light Dimming Module Wiring Diagram

Programming

- The Light Dimming Module is configured in a Lighting Control application.
- The E2 software must be 2.40F01 or later.
- A light level sensor is required to control the light dimming.

Program the Lighting Application normally. Then, make the following additional programming changes:

1. Press **Log In/Out** and log in to the E2 with Level 4 access.
2. Press **F2** view the Lighting Summary screen. If a list of Lighting Control applications appears, highlight the one you wish to edit and press **Enter** to view the **C1: Setup** screen.
3. If proofing is desired, change the **Enable Proofing** field to Yes. Change **Enable Dimming** field to **Yes**.

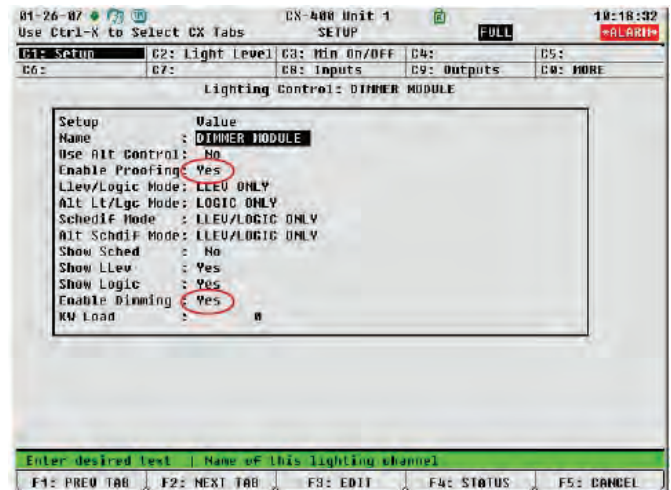

E2 Setup Screen

1. Press **F2** to view the **C2: Light Level** screen.
2. Set the values encircled in the next graphic based on the desired lighting operation.
 - **Dim Upper:** Light output percent at Dim LL @ Upper % light level
 - **Dim LL @ Upper:** Light level for Dim Upper % output
 - **Dim Lower:** Light output percent at Dim LL @ Lower % light level
 - **Dim LL @ Lower:** Light level for Dim Lower % output
 - **Dim Ramp Speed:** Ramp speed in percent change per minute.

4. Assign the **Dimmer** output to the MultiFlex Analog Output connected to the dimmer module.
5. Press **F2** to view the **C0: More** screen.
6. Change the **Proof Type** to **ON Only**.
7. Assign the Proof IN input to the MultiFlex Analog Input connected to the dimmer module.

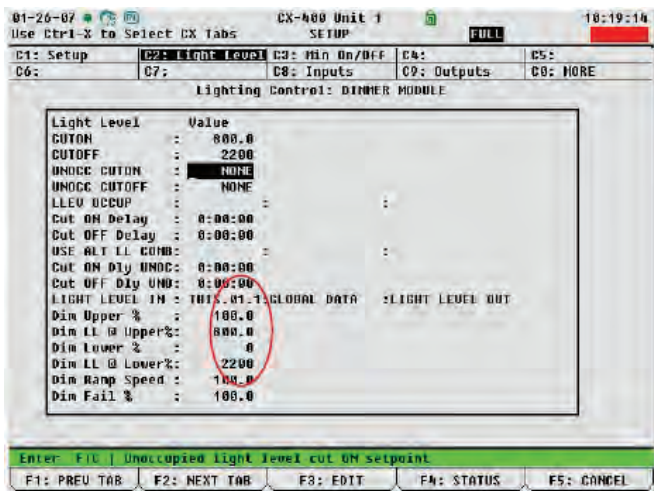

E2 Setup Screen (Dim Values)

- **Dim fail:** Light level output if light level sensor fails.
3. Press **Ctrl** + **S** to view the **C9: Outputs** screen.

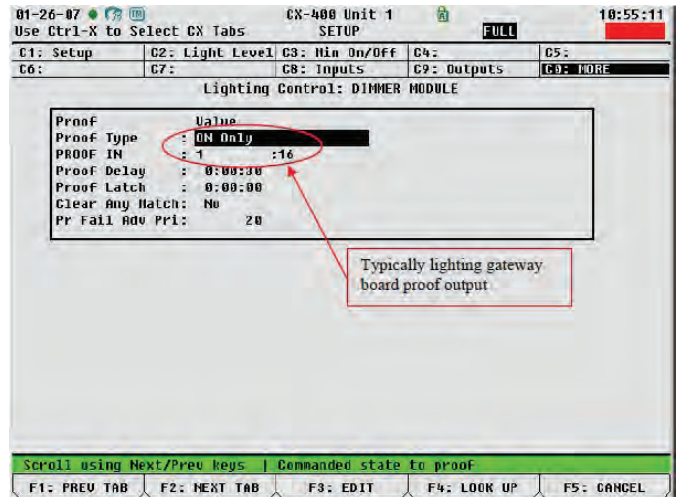

E2 Setup Screen (Dimmer Module Proof Type)

Application Notes

1. Typically, the physical proof output from the Light Dimming Module is used as an alarm from a Digital Sensor Control application in the E2 controller. A delay of 5 minutes is recommended to minimize nuisance alarms.
2. The isolator provides electrical isolation between the ballasts and the Light Dimming Module. The isolator separates the ground on the control wire from the input board. It is highly recommended that the signal isolator be used in all applications to prevent grounding issues with the lighting fixtures and the 4AO (-).

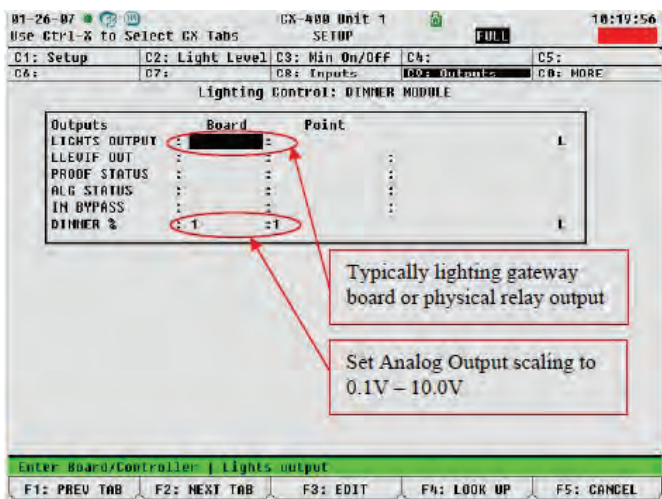

E2 Setup Screen (Dimmer Module)

Defrost Timer Board

P/N 537-3047

Overview

Defrost Timer replacement board is designed to physically replace the defrost clock in refrigeration condensing units. Refrigeration solenoid control, defrost heater contactor, and evaporator fans are done through the use of 24VAC Class 2 transformer. Low temperature systems such as a walk-in freezer will use all three relays on the defrost board to control the refrigeration solenoid, defrost heaters, and evaporator fans. Medium temperature systems like walk-in coolers use only one relay on the defrost board, switching the liquid line solenoid.

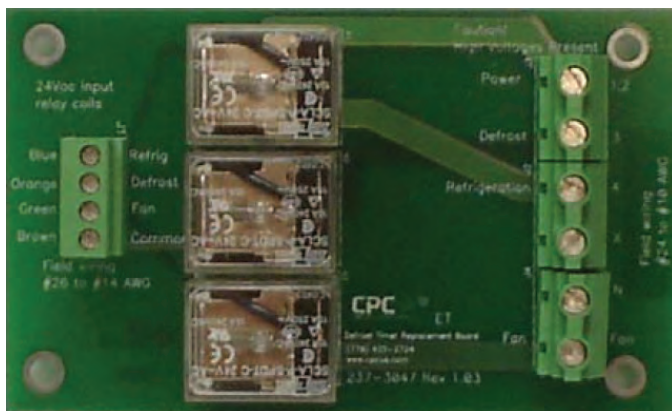

Defrost Timer Board

- When the defrost heater Klixon senses enough heat, it closes, sending voltage back to the time clock to Terminal X. This activates an internal plunger that forces the time clock out of defrost and back into refrigeration mode.
- Terminal 4 is now active again, supplying voltage to L1 of the solenoid and fans. Because the thermostat is closed due to the box temperature being above set point, the solenoid opens starting the refrigeration cycle. The fans do not start because the Klixon on L2 is still open. When the evaporator closes, allowing the fans to start. This prevents a blast of hot air from the built-up heat of the defrost heaters.

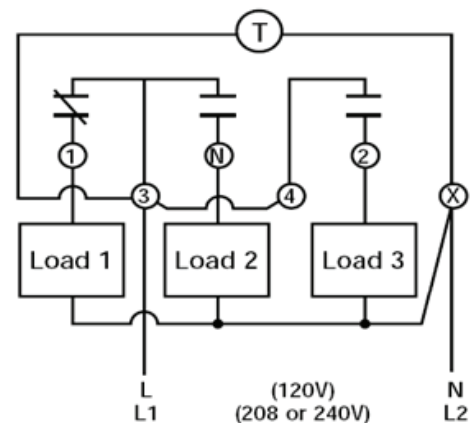

Time Clock Operation

Original Time Clock Operation

- Time Clock enters defrost. Terminal 4 on the clock is deactivated. Terminal 4 shuts off L1 of the fans. Fans are OFF. It also shuts off L1 of the liquid line solenoid. Solenoid is OFF and the system pumps down. L1 is now active to the defrost heaters from Terminal 3 of the time clock, so the heaters are ON.
- During the defrost cycle, the Fan Klixon opens due to temperature increase. L2 for the fan circuit is now OFF. The defrost heaters remain ON.

Defrost Timer Board Installation

The Defrost Timer Board is installed in the old time clock location. To simplify the installation, the defrost timer board includes snap track.

The snap track should be secured using the appropriate mounting hardware. Then, install the installation paper inside the snap track. The defrost timer board can then be mounted inside the snap track. The defrost timer board is wired to an 8RO board as shown in the 537-3047 Defrost Timer Board to 8RO Wiring Diagram.

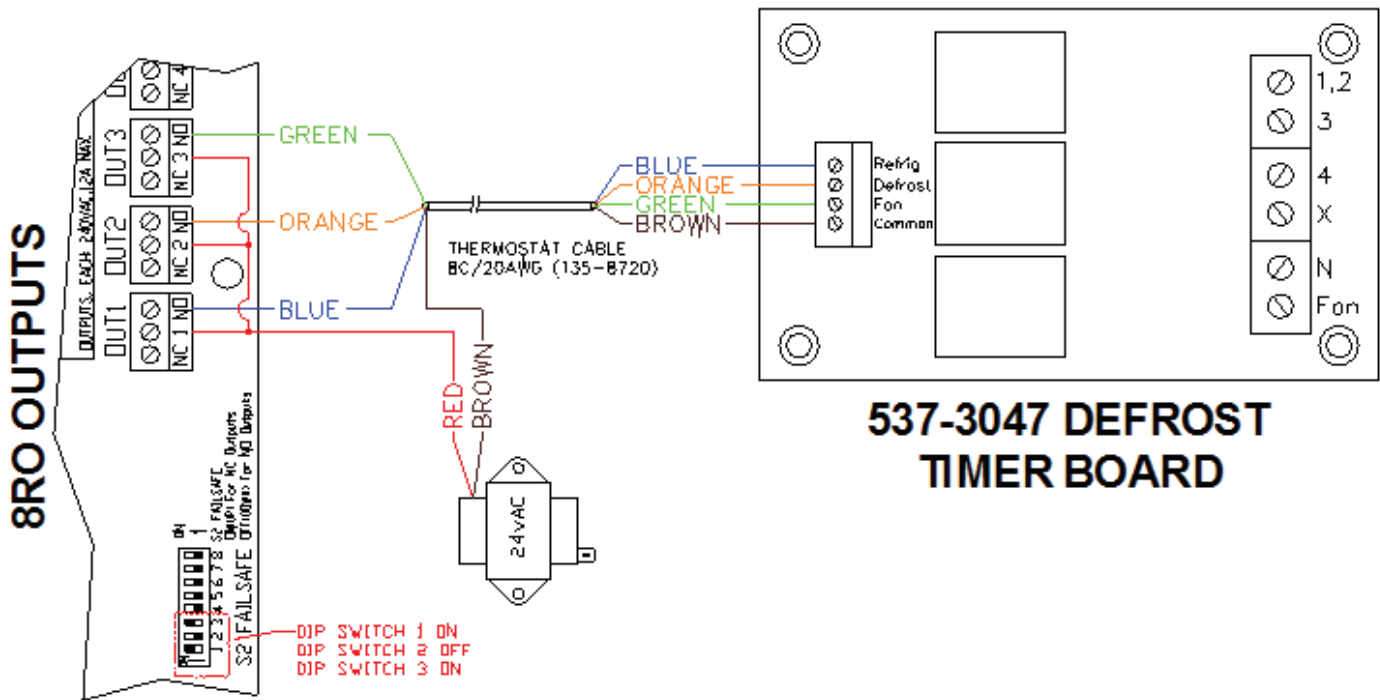

537-3047 Defrost Timer Board to 8RO Wiring Diagram

The system controls the solenoid, fans, and defrost heat separately. The controller has the ability to adjust the fan delay and defrost duration through programming. Defrost termination is accomplished with the use of an evaporator-mounted temperature sensor. Thus, you must eliminate both coil-mounted Klaxons.

During the retrofit, you may find that you are lacking one wire between the time clock and evaporator to accomplish independent control of the fans and solenoid. Because you no longer need the defrost termination Klaxon (wired to terminal X), you can reuse this wire to separate the fans from the refrigeration solenoid.

1. Power-down the condensing unit. Remove the time clock and install the Defrost Timer Replacement Board as illustrated in the 537-3047 Defrost Timer Board to 8RO Wiring Diagram. Connect the wire from terminal X of the time clock to Fan on the replacement board.
2. In the freezer, remove the existing mechanical thermostat. Install a weatherproof junction box in its place and wire the two leads together.
3. In the evaporator, remove the defrost termination Klaxon and rewire in accordance with NEC guidelines for wet locations. Install the defrost termination sensor (Part # 501-1127).
4. At the point on the terminal block where the wire

from Terminal 4 from the original time clock is attached, trace the wires leaving that terminal to determine which control the fans and which go to the solenoid. Leave the solenoid attached, but remove the fan connection and attach it to the wire that was originally connected to the defrost termination Klaxon (Terminal X on the original time clock).

5. Locate the fan Klaxon installed in series with L2 of the fan circuit. Remove the Klaxon and rewire in accordance with NEC guidelines for wet locations.
6. Confirm all wiring connections, re-power the unit, and check all modes of operation. The fans should shut off immediately upon defrost initiation, and should delay coming back on for the fan delay duration programmed in the controller, following expiration of the drip time. Make sure the fans remain running when the system reaches set point and the refrigeration solenoid cycles off. If they do not, confirm in the circuit application of the controller that the fan strategy is set to ON during offcycle. If this is correct, re-check your wiring of the evaporator

The rewiring of the evaporator will vary based on the type of evaporator. The typical rewiring sequence is shown in the Evaporator Wiring Diagram Before Installation and Evaporator Wiring Diagram After Installation below.

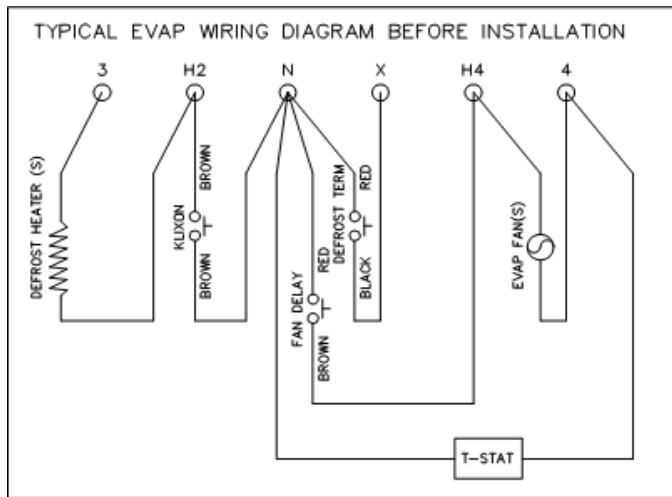

Evaporator Wiring Diagram Before Installation

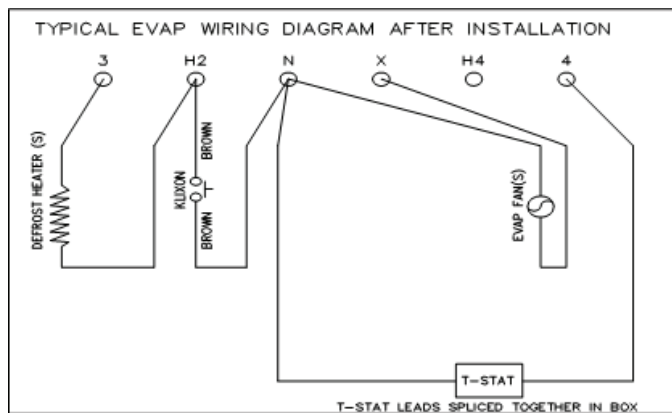

Evaporator Wiring Diagram After Installation

Proper Operation, Confirmation and Troubleshooting

The refrigeration and fan relays are normally closed, while the defrost relay is normally open. In the event of a system failure, refrigeration and fan relays will remain closed, and defrost will be open. When activating the relays in this configuration, we send 24VAC to the terminal on the left-hand side of the board for each load.

For refrigeration and fans, we send this voltage to turn the load OFF. We send the voltage to the defrost relay to turn the heaters ON. When using a voltmeter to troubleshoot this board, measuring AC voltage on the low voltage connection, you will see the following values:

Present Condition	Terminals Tested	Voltage
Refrigeration ON	24V Common to Refrigeration	0V
Refrigeration OFF	24V Common to Refrigeration	24V
Defrost ON	24V Common to Defrost	24V
Defrost OFF	24V Common to Defrost	0V
Fan ON	24V Common to Fan	0V
Fan OFF	24V Common to Fan	24V

When using this board for a walk-in freezer, or a multi-deck case with electric defrost heat, all 24V control points will be used. Eliminate the fan Klixon located on the evaporator. The E2 Controller will then assume all operation of the fan delay following defrost.

In some instances, the condensing-unit-to-evaporator wiring will not include a wire dedicated for fan control. These units use terminal 4 from the existing time clock to power L1 of the refrigeration solenoid and L1 of the fan circuit. Because the E2 Controller activates defrost termination based on coil temperature, you must remove the defrost termination Klixon from the evaporator. The wire that was previously connected to the defrost Klixon—X on the existing time clock—is rewired to L1 of the fan circuit and connected to the fan relay of the Defrost Timer Replacement Board.

When this board is used in a walk-in cooler application where fan control and defrost heat are not needed, the 24V control will consist of the refrigeration solenoid only. The two remaining control relays on the Defrost Timer Replacement Board will not be used.

Terminals N and X on the Defrost Timer Replacement Board are passive in that they do not connect to anything control related. They are simply there to land the unused wires from the time clock during conversion to control.

Because the voltages to the Defrost Timer Replacement Board low-voltage inputs originate at the outputs of the Form C relays of the 8RO boards, you may need to check voltages there as well if the readings listed above are incorrect. Follow these guidelines to confirm proper operation of the outputs. Testing the voltages here will be the same as checking them at the Defrost Timer Replacement Board. If no voltages are present regardless of the state of the output, check the 2-amp fuse located on the 8RO board. If the fuse is not blown, trace the control circuit back to the control transformer, making sure all connections are sound. If all connections are good, disconnect the quick-connect spade connectors located near the secondary output of the control transformer and check the voltage. If 24VAC is not present, check the 120V primary voltage to the transformer. If the 120V supply is present, replace the control transformer with a Class 2, non-center-tapped, 120V primary, minimum 50VA rated transformer.

If some or all of the voltages between Terminals Tested and Voltage Present in the chart above appear to be reversed (meaning, for example, that Refrigeration ON shows 24V, and Refrigeration OFF shows 0V, etc.) then the problem can be resolved by checking the failsafe dip switches on the 8RO board. Printed on the board near the failsafe dip switches you will see markings indicating the correct position of the switches for ON or OFF. Follow these simple rules to confirm the correct positions. If the output is for refrigeration or evaporator Fans, the switch should be in the ON position.

If the output is for defrost or HVAC Heat/Cool/Fan stages, the switch should be in the OFF position. If you make changes to the network dip switches, you must power the board down for five seconds by pulling the 24VAC plug. When you restore power to the board, it will re-read the switch settings.

Carbon Dioxide Aspiration Box - Duct Enclosure

P/N 210-2009

Overview

The CO₂ aspiration box (P/N 210-2009) is designed specifically for use with CO₂ sensor (P/N 510-2001). The enclosure allows the standard wall mounted room sensor to be used as a duct sensor. The enclosure is designed for in-duct sampling of CO₂ concentrations at flow rates greater than 400 fpm. The enclosure is screwed to the duct with the probe inserted into the airstream. The air sampling probe is 1 in. (25.4 mm) in diameter and 8 in. (203.23 mm) long. The enclosure is made of ABS plastic. It has knockouts for conduit connections. The CO₂ sensor is not included with the enclosure. The CO₂ sensor (P/N 510-2001) must be ordered separately.

Enclosure Dimensions

The enclosure is 7" Tall x 4.25" Wide x 3.5" Deep (with cover). The four mounting holes are equally spaced at 6.5" x 3.75". The insertion tube is located in the center of the enclosure.

Digital Scroll Condenser Board

P/N 810-3250

Overview

The Digital Scroll Condenser Unit Controller is designed to control condensing units with a Copeland's Digital Scroll compressor. The controller will operate the Digital Scroll's motor, solenoid valve, and vapor injected solenoid valve to vary the compressor's capacity from 10% to 100%. The controller can control up to two condenser fan motors. The controller can maintain the operating setpoint by suction pressure, lead case temperature, or both.

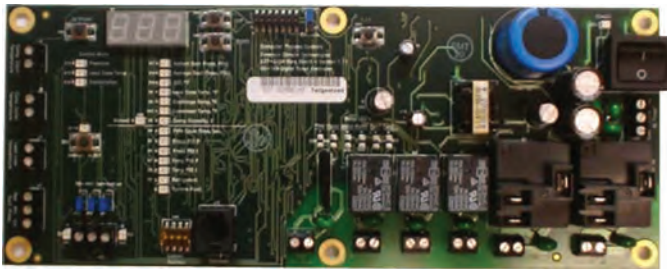

Digital Scroll Condenser Board

Inputs

- Digital Scroll Discharge Temperature Sensor
 - Condenser Temperature
 - Lead Case Temperature (optional) *
 - Suction Pressure Transducer (optional) *
- *One (or both) of the sensors must be installed

Outputs

PWM Solenoid Valve

- > 1.5A@24 to 240VACBu

Vapor Injection Solenoid Valve

- > 7A @ 240VAC, 10A@120VAC, 180VA Pilot Duty

Compressor Motor Contactor

- > 7A @ 240VAC, 10A@120VAC, 180VA Pilot Duty

Condenser Fan 1

- > 600VA Pilot Duty at 120, 208, or 240VAC

Condenser Fan 2

- > 600VA Pilot Duty at 120, 208, or 240VAC

Alarm

- > > 7A@240VAC, 10A@24 to 120VAC, 7A@30VDC

Highlights

- Three LED "seven segment" display
- Alarm Output
- Compatible with R-404A, R-407C, R-22, R-134a, or R-410A
- High Discharge Protection
- Condenser Fan Lead / Lag Operation
- Compressor and Fan Short Cycle Protection

Physical Dimensions	4" Tall x 10" Wide x 3" Deep
Power Requirements	120/240 Volt
Input/Output Terminals	Fixed screw terminals
Operating Temperature	-40°F to +149°F (-40°C to +65°C)
Humidity	5% to 95% Relative Humidity (non-condensing)
Vibration	V2 vibration level

Block Diagram

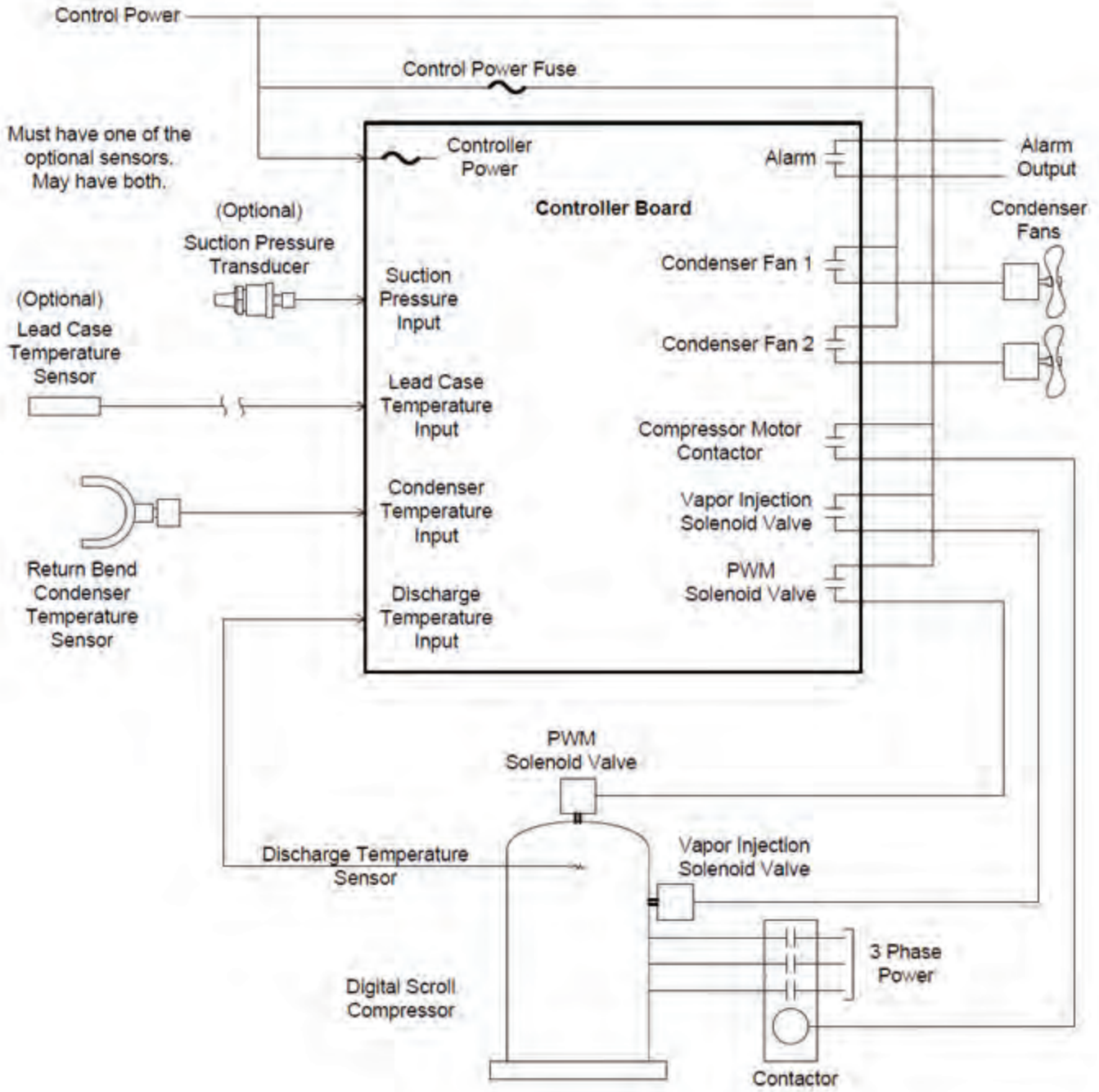

Digital Scroll Condenser Board Block Diagram

DPC-5 Dewpoint to Temperature Converter

P/N 812-0102

This device, Part Number 812-0102, is used to convert a 0-10VDC signal to 0-5VDC. The output mimics the curve of a standard 10k temperature thermistor.

One use of the device is to, through an analog combiner, read space temperature and space humidity, convert those readings into dewpoint, scale the dewpoint reading to a 0-10VDC analog output, then connect the output of the DPC-5 to a 16AI point to reference dewpoint temperature.

The labeling on this device can be a bit misleading. The connection bank listed as Output is in fact the input of the AO point voltage. The connection bank listed as Input connects to the 16AI board point.

The following steps can be used to troubleshoot the device in the field. You must have a Hand-Held Terminal, Part Number 814-3110, to properly check the device. The DPC-5 must be powered using a minimum 10VA, 24VAC, Class II Non-Center-Tapped Transformer.

1. Connect the HHT to the DPC-5. Apply **0 volts** to the input harness.
2. From the main menu of the HHT (F2) select option **2** (In Volt). Right arrow (→), **2** (In Volt), then down arrow (↓) twice to get to the input screen. Record the input voltage reading for each input.
3. Go to the Configuration Screen (CFG). Using the HHT press **F2**, right arrow (→), **4** (CFG), then down arrow (↓) twice to get to the configuration screen.
 - If necessary, change the **EU** (Engineering Units) from DC to **DF** using the period (.) key. Use the right arrow (→) to get to this field.
 - Use the right arrow (→) to move to each input and enter the recorded voltage reading for that input from Step 3.
 - Press down arrow (↓) twice to return to the main menu.
4. Apply 5.000 volts to the input harness.
5. Go to Out Temp screen to verify the converted

temperature. Press right arrow (→), 1 (Out Temp), then down arrow (↓) twice to get to the output screen. The reading for each output should be 50 +/- 0.5 degrees (>= 49.5 and <= 50.5).

6. On output connector J6 verify that the output voltage for each output is 2.25 +/- 0.5 volts (>= 2.20 and <= 2.30).
7. Remove 24 VAC. Remove the output harness, 5VDC source, and HHT. The unit is ready for use once all final connections are made.

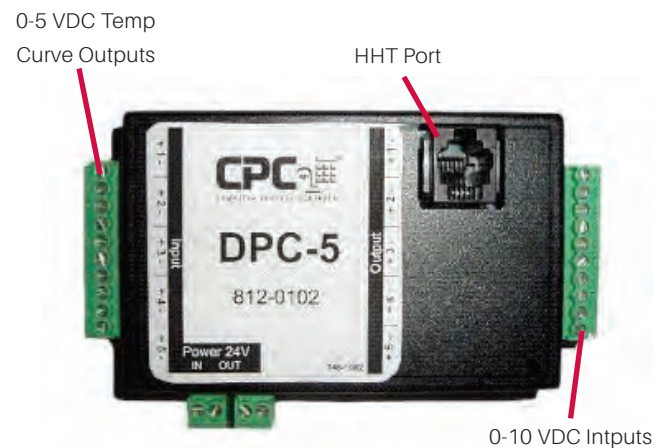

AC Power Meter

P/N 250-0450

Overview



The WattNode® Plus is a LonWorks® and an open echelon device that can be controlled by the E2. The WattNode Plus is a networked, multi-function digital power meter and monitor that offers energy monitoring, sub-metering, demand management, power factor control, and phase-load monitoring.

For more information on WattNode Plus device, refer to the official website of Continental Control Systems (<http://www.ccontrols.com>).

Installation



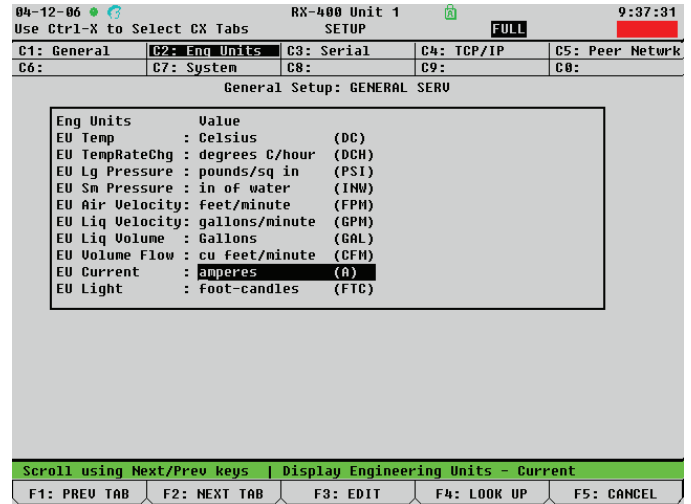

The WattNode Plus device requires a license key and a description file before installing the device. If the license is ordered with the E2, the description file and the license will be installed before shipping. The echelon cable should be connected to the Echelon port on the E2 power interface board.

Outputs

1. Press    to view the **C2: ENG UNITS** screen.
2. Scroll down to EU CURRENT parameter and change the parameter value to “amperes (A)”.



General Setup Screen

3. Press     to display the CONNECTED I/O screen.
4. Under the THIRD PARTY DEVICES section, add the number of Open Echelon devices. Use the E2 number keypad on the front panel to enter the number of WattNode devices.

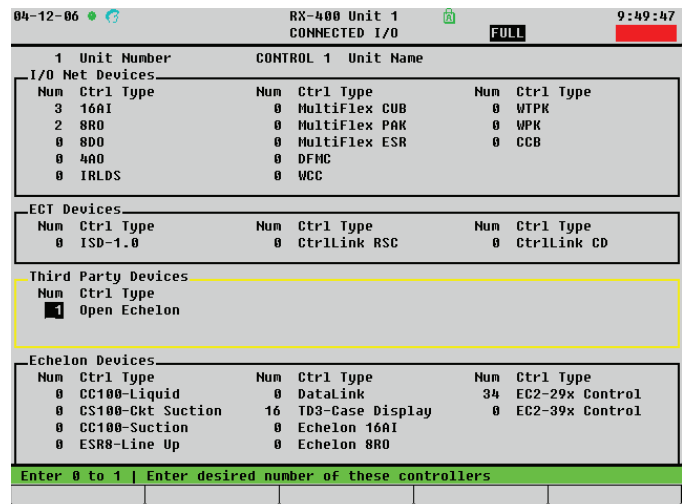

Connected I/O Screen

1. Press **Menu** **F7** **F7** **F3** to view the CONTROLLER SETUP screen.

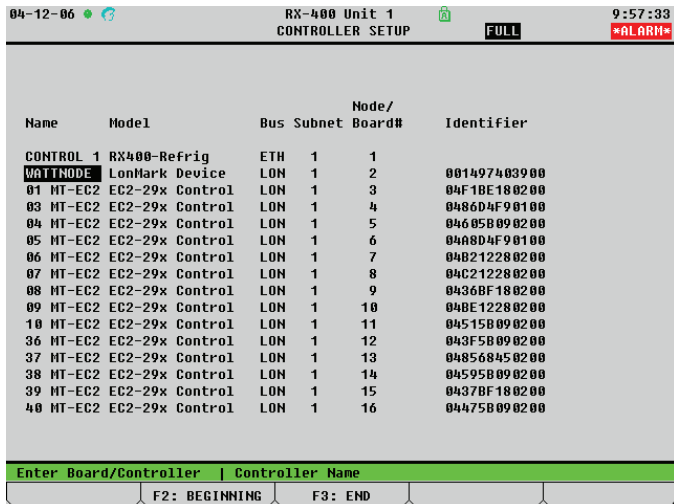

Controller Setup Screen

2. On the CONTROLLER SETUP screen:
 - Scroll down to WATTNODE (this will highlight the device name).
 - The Identifier field will display UNKNOWN for the device if the address is not set up. To set up the address, press **F4**. On the pop-up window, select the method to use in setting the controller address:
 - > Press **1** to use the service pin on the WattNode Plus device. The device will send its address to E2.
 - > Press **2** to manually enter the Neuron ID(s) located on the WattNode Plus device.

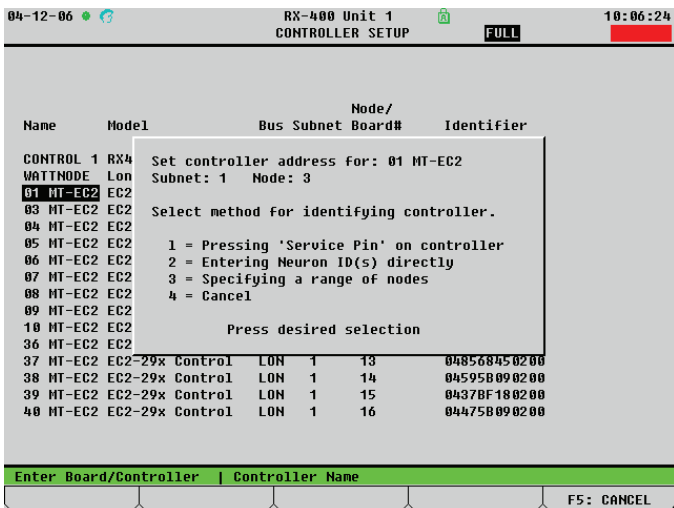

Controller Setup Screen(Set Controller Address)

3. Press **Menu** **F5** (CONFIGURED APPLICATIONS), and select WattNode in the list of applications.
4. On the device status screen, press **F5** (SETUP). Press **F2** (NEXT TAB) to view the C2: SETPOINTS screen.
5. For the CTAMPS parameter, enter the Amperage rating of the Current Transducer (CT) that is connected to the WattNode device. CTs come in varying sizes and Amperage ratings; see CT tables on the next section for reference on CT Amperages and Inside Diameter sizes.

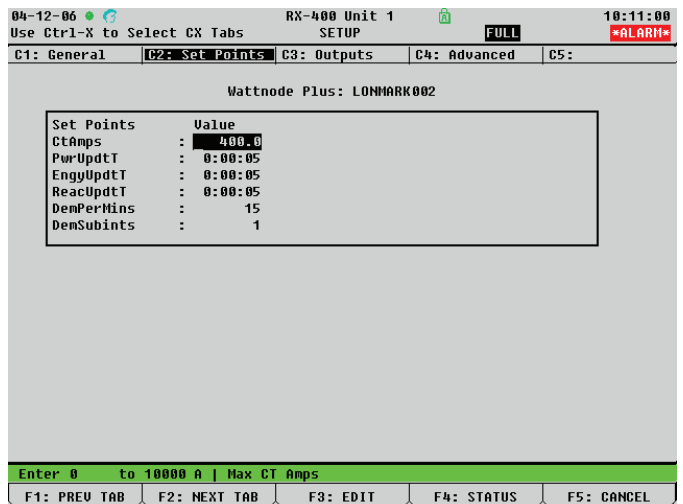

Controller Setup Screen (CTAMPS Parameter)

6. From the C2: SETPOINTS screen, press **F2** to move to C3: OUTPUTS screen.
7. Scroll down to POWERSUM parameter and enter the board and point address to the WattNode Plus application input, or press **F4** to LOOK UP.

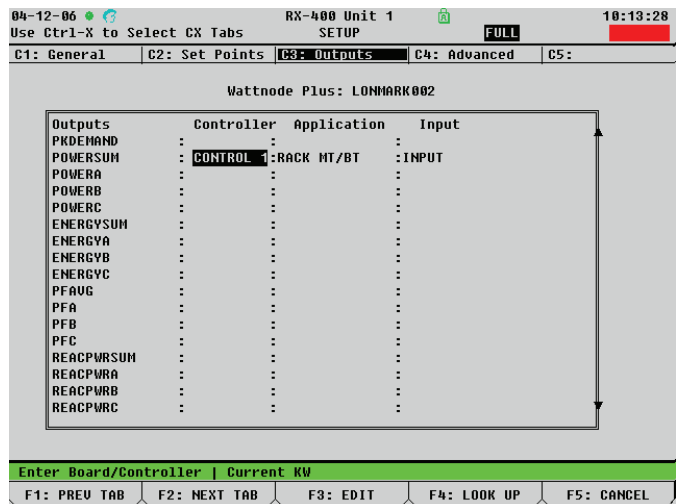

Controller Setup Screen (POWERSUM Parameter)

Current Transducers Compatible with WattNode Plus

P/N	Inside Diameter	Amperage
251-1000	0.75"	5
251-1001	0.75"	15
251-1002	0.75"	30
251-1003	0.75"	50
251-1004	1.25"	70
251-7010	0.75"	100
251-1005	1.25"	100
251-1006	1.25"	150
251-7021	0.75"	200
251-7020	1.25"	200
251-1007	1.25"	250
251-1008	1.25"	300
251-7030	1.25"	300
251-1009	1.25"	400
251-7040	2.00"	400
251-7080	2.00"	800
251-7120	2.00"	1200

Split Core Current Transducers

P/N	Inside Diameter	Amperage
251-1020	0.30"	5
251-1021	0.50"	15
251-1022	0.50"	30
251-1023	0.75"	50
251-1025	1.00"	50
251-1024	0.75"	70
251-1026	1.00"	70
251-1030	1.25"	70
251-1027	1.00"	100
251-1031	1.25"	100
251-1028	1.00"	150
51-1029	1.00"	200
251-1032	1.25"	200
251-1033	1.25"	250
251-1034	1.25"	300

Solid Core Current Transducers

New Center-Tapped Transformers

P/N 640-00XX

This technical bulletin announces the discontinuation of the Three-Board and Six-Board center-tapped transformers used to power 16AIs and other I/O boards. This bulletin also introduces two new center-tapped transformers offered as replacements, along with instructions on how to install them.

Overview

Effective immediately, two of the three center-tapped transformers supplied by Copeland for powering 24VAC I/O boards will no longer be shipped with new orders. The discontinued transformers are:

- P/N 640-0043, Three-Board Transformer, 56VA, 110/220VAC to 24VAC, center-tapped.
- P/N 640-0045, Six-Board Transformer, 100VA, 110/220VAC to 24VAC, center-tapped.

The new transformers that are offered in place of the discontinued transformers are:

- P/N 640-0056, Three-Board Transformer, 56VA, 120/208/240 to 24VAC, center-tapped.
- P/N 640-0080, Four-Board Transformer, 80VA, 120/208/240 to 25VAC, center-tapped.

Handling New Orders for Discontinued Transformers

All new orders for the discontinued 640-0043 transformer will be fulfilled with the replacement 640-0056 transformer. However, since there is no equivalent replacement for the 640-0045 (100VA) transformer, new orders for this transformer will not be fulfilled. Customers who want the 640-0080 (80VA) transformer in place of the obsoleted 640-0045 must specifically order the new 640-0080 transformer.

Installation

The 56VA and 80VA transformers are wired in the same manner. The diagram below shows how to wire both transformers.

Primary Side

1. Wire the BLUE (neutral) wire to the quick-connect terminal marked C.
2. Wire the BROWN (hot) wire to the 120, 208, or 240 terminal, depending on the input voltage being used.

Secondary Side

1. Wire the 24V or 25V quick-connect terminal to terminals AC1 and AC2 on the I/O board.
2. Connect the CT quick-connect terminal to terminal 0V on the I/O board.

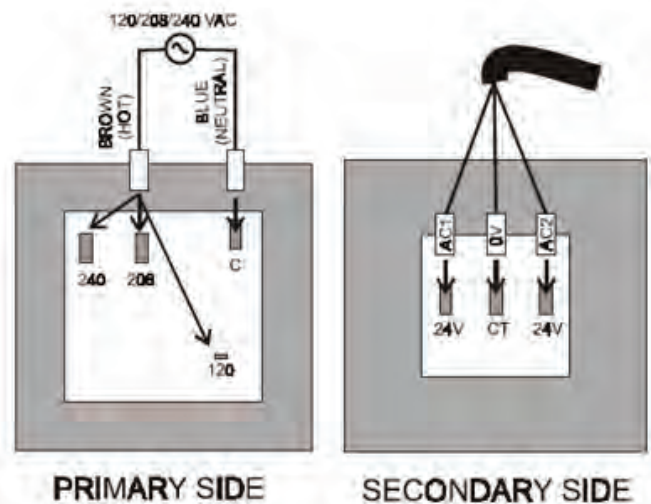

Hot Food Temperature Monitor

P/N 508-9121

Overview

The 508-9121 is Copeland's Hot Food Temperature Monitor. The monitor is available in black (P/N 508-9121). The temperature sensor has a 10K Ω thermistor that is enclosed in a stainless steel housing with FDA-EP2 epoxy. The sensor has a black 20' pigtail. The wire is NSF approved 22 AWG / 2 Conductor. The sensor has been tested to maintain less than 0.72°F error between 70 and 250°F.

Do not exceed 250°F (maximum temperature 250°F).

Installation

The sensor connections to the input point on the 16AI board are not polarity sensitive. The sensor is connected as shown in the Sensor Wiring Diagram. The sensor can be wired to any available point on the 16AI board. Connect one lead to the 0V input, and connect the other lead to the SIG input.

The dip switch for the 16AI input should be set to the ON position.

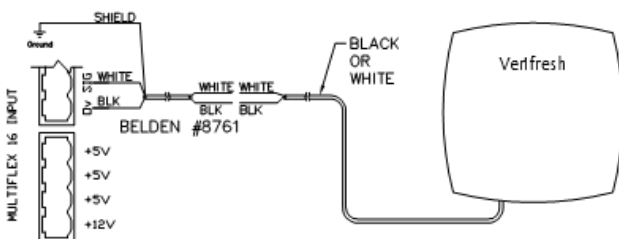

Sensor Wiring Diagram

The sensor includes a plastic insulated clamp for securing the sensor. Mounting hardware is not included with the clamp. The sensor can also be secured using standard cable ties (not provided).



Hot Food Temperature Monitor P/N 508-9121

Resistance Chart

The accuracy of the resistor can be verified using an Ohm meter. The chart below shows the resistance for various temperatures.

Temperature (°F)	Temperature (°C)	Resistance (Ohms)
70	21	11,883
80	27	9,299
90	32	7,334
100	38	5,828
110	43	4,664
120	49	3,758
130	54	3,048
140	60	2,488
150	66	2,043
160	71	1,668
170	77	1,400
180	82	1,169
190	88	981
200	93	827
210	99	701
220	104	597
230	110	511
240	116	439
250	121	378

Pressure Transducers

P/N 800-2XX0

Overview

The family of pressure transducers has a stainless steel housing with a 1/8" male national pipe thread (NPT) fitting. The rugged design makes the transducer compatible with all HFC/HCFC refrigerants, water, glycol, CO2, and ammonia. The sensor includes a 20' cable with a weather-proof Packard connector to allow for ease of sensor replacement. The sensor is available in six pressure ranges. The specifications for each sensor are listed below:

Part Number	800-2100	800-2200	800-2500	800-2650	800-2710	800-2720
Pressure Range	0-100 PSI	0-200 PSI	0-500 PSI	0-650 PSI	PSI 0-1000 PSI	0-2000 PSI
Proof Pressure (PSI)	200	400	1000	1087	2000	4000
Burst Pressure (PSI)	500	1000	2500	3250	5000	10000
Supply Current	10mA max			13mA max		
Max per MultiFlex or 16Al (50mA max)	5			3		
Accuracy	Less than ±2% span			Less than ±2.5% span		
Operating Supply Voltage	5.0±0.05 VDC 1%					
Output Voltage	0.5 to 4.5 VDC					
Output Load	10 kOhm min					
Insulation Resistance	Greater than 100 MOhm at 50 VDC for 1 minute					
Operating Temperature	-40°F to +257°F (-40°C to +125°C)					
Storage Temperature	-40°F to +257°F (-40°C to +125°C)					
Durability	Greater than 1 million cycles					
Response Time	Less than 5 msec					
Vibration	11 g					
Drop Test	1 meter on 3 axis					
Electrical Connection	Packard Electric Metri-Pack Series					
Pressure Connection	1/8- 27 NPT					
Vacuum Tightness	Yes					
Agency Approval						



P/N 800-2100

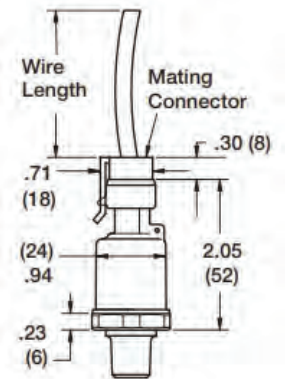

P/N 800-2XX0 Dimensions

Installation

The sensor connections to the input point on the 16AI board are polarity sensitive. The sensor is connected as shown in the wiring diagram. The sensor can be wired to any available point on the 16AI board.

The dip switch for the 16AI input should be set to the ON position.

ONLY CONNECT THE PRESSURE TRANSDUCER TO A +5V DC TERMINAL.

During routine troubleshooting and commissioning, transducer may be exposed to a vacuum environment.

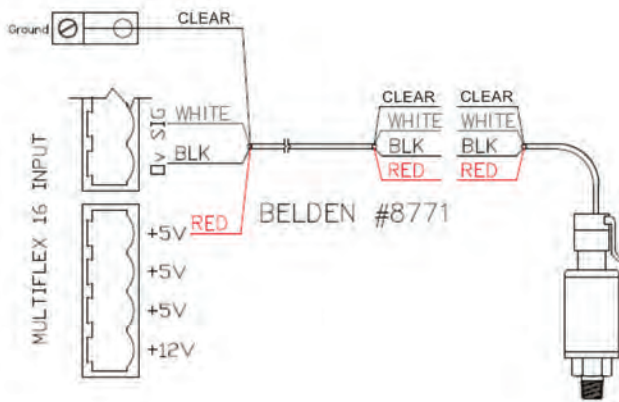

4. Press **F1** **I** to create an analog input and set the following parameters.
 - a. Change Sensor Type to Linear
 - b. Change Eng Units to PSI
 - c. Setup Method: Endpoint
 - d. Low End Point: 0.5V
 - e. HighEnd Point: 4.5V
 - f. Low End EU: 0
 - g. High End EU: the Highest Pressure range based on the model
 - h. Low End Limit: 0.1
 - i. HighEnd Limit: 4.9
5. Type in the desired name for the point in the point Name field.



E2 Programming - Manually Set Up Pressure Transducer Inputs

1. Press **Log In/Out** and log in to the E2 with Level 4 access (default login USER/PASS).
2. Press **Alt** + **I** to view the INPUT STATUS screen.
3. Use the arrow keys to highlight the correct board and point for the pressure transducer.

Type	Board	Point	Type	Application	Association	Value	ADVISORY SUMMARY
16A1	01	01	A	PRESSURE	SUCTION PRES	356.25 PSI	Falls: 0 Alarms: 0 Notices: 0
16A1	01	02	A	PRESSURE	DISCHARGE PRES	765.00 PSI	
16A1	01	03	-	-	-	-	
16A1	01	04	-	-	-	-	
16A1	01	05	-	-	-	-	
16A1	01	06	-	-	-	-	
16A1	01	07	-	-	-	-	
16A1	01	08	-	-	-	-	
16A1	01	09	-	-	-	-	
16A1	01	10	-	-	-	-	
16A1	01	11	-	-	-	-	
16A1	01	12	-	-	-	-	
16A1	01	13	-	-	-	-	
16A1	01	14	-	-	-	-	
16A1	01	15	-	-	-	-	
16A1	01	16	-	-	-	-	

6. Use the arrow keys to highlight the **Sensor Type** field and press **F4** to change the sensor type.
7. For an **800-2100**, press **E**; for an **800-2200**, press **F**; for an **800-2500**, press **G**; for an **800-2650**, press **A**.
8. Press **Enter** to accept the sensor input.

XM Series Case Controls

P/N 318-6522, 318-6601, 318-6702

Overview

The new version of the XM series case controls is performance enhanced, efficient and flexible to meet market needs. One of the strengths of the 5.4 version is its pre-configured maps for easy installation and backwards compatibility in existing installations.

Now it is also possible to update the controller directly from the field by adding new refrigerants or updating the firmware with new functions.



XM 5.4

New Features

The 5.4 version introduces important functions that improve performance for the entire controller family while complying with new environmental protection rules.

1. Ease & performances



All models have the same firmware platform to ensure the same robust performance whether using a stepper or a PWM valve. Common parameters and functions provide ease of use and maintenance.

2. Auto-adaptive superheat

The new auto-adaptive algorithm for superheat management improves the case performance for ease of use and energy savings.

3. Multi map



XM600 controllers have different kinds of applications that have been optimized after laboratory testing. The customer can choose the most suitable solution: low temperature, medium temperature with or without auto-adaptive superheat, and more.

4. Quick update



All XM600 controllers can be easily reprogrammed directly in the field.

5. Natural refrigerant updating



XM600 controllers can be updated directly in the field by adding new refrigerants or updating the software with new functions that align with market trends and comply with current regulations.

6. Service functions



- > Clean mode function - This new function allows the case to be washed safely without disconnecting it from the monitoring system.
- > Stepper valve auto-calibration - This useful function allows the autocalibration of the stepper valve in order to optimize the step adjustment.

7. High compatibility

Compatible with previous versions (r2.8, 4.2, 3.0), the LAN allows new controllers to be installed in pre-existing networks receiving the same commands and sharing the same information, such as: pressure, defrost synchronization, light synchronization, cold demand, auxiliary activation to drive the anti-sweat heaters, and more.

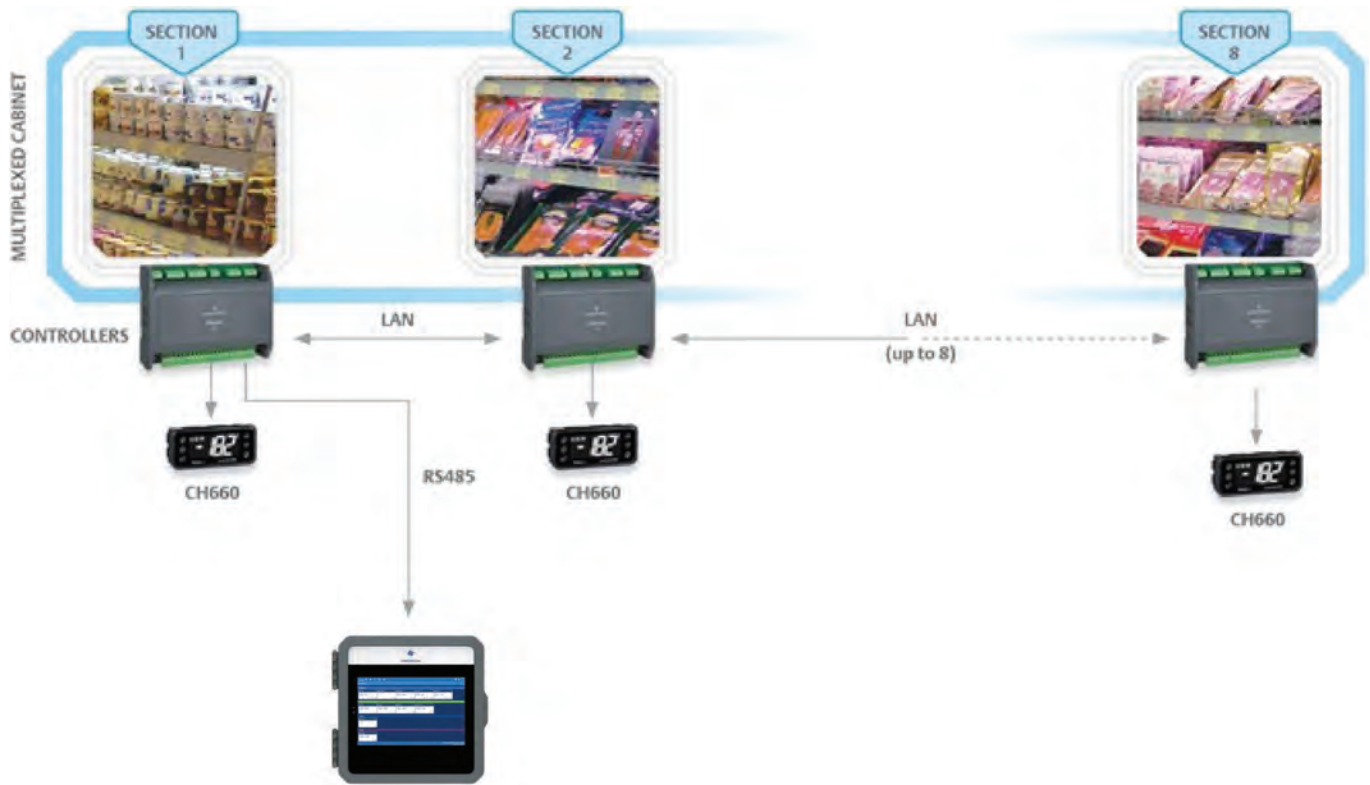

1. Fast communication



Faster communication (19.2k) between controllers and supervisory systems allow the case to be monitored in real time for prompt intervention in case of alarms.

2. High flexibility



The XM600 series is even more flexible. It can be also be used in self contained cases where 2 probes can be configured as digital inputs to monitor compressor status.

3. Cold room application



Use up to 5 probes for temperature regulation to ensure uniform room temperature. Room temperature can be set according to the probe average or on the highest detected temperature.

4. Hot Key 64K



XM600 controllers 5.4 version use the new programming key (code DK00000300) to download the parameter map. The previous Hot Key in 4K is no longer compatible.

5. On demand defrost

In addition to standard defrost modes (interval or time), XM600 controllers are now equipped with a new self-learning algorithm to start defrost only if needed. Evaporator operating conditions are monitored constantly, and the defrost starts automatically only when the controller detects that it is needed. This ensures consumption optimization because the defrost is performed according to the real working conditions and only when the evaporator starts losing efficiency. It is possible to set safety conditions such as the minimum or maximum interval between defrosts in order to meet different case features.

Specifications

	XM670K ALL VERSIONS	XM678D ALL VERSIONS	XM679K ALL VERSIONS
Power Supply	110/230V	24V	
Communication	RS-485 Modbus	RS-485 Modbus	RS-485 Modbus
Analog/Digital	Analog inputs: 4 Digital inputs: 3	Analog inputs: 6 Digital inputs: 3	Analog inputs: 6 Digital inputs: 3
Relay Outputs	5 outputs	5 outputs	6 outputs
Superheat Control?	No	Yes	Yes
Antisweat?	Yes	Yes	Yes
Power Consumption	9VA	20VA	9VA
Type of Valve	Solenoid valve	Stepper valve	Pulse valve

Specifications

Specifications

	PART NUMBER	CONTROLLER
XM CASE CONTROLLERS	318-6522	XM670K Solenoid Control New Version 5.4
	318-6601	XM678D Stepper Control New Version 5.4
	318-6702	XM679K Pulse Control New Version 5.4
XM ACCESSORIES	318-6510	XM-F16 Connectors for XM670K
	318-6610	XM-FC26 Connectors for XM678D
	318-6710	XM-FC21 Connector for XM679K
	318-6750	CX660 Remote Display & Keyboard for XM's
	501-1125	Temperature Sensor Blue (Coil-in)
	501-1126	Temperature Sensor Red (Dis. Air)
	501-1127	Temperature Sensor Org (Def. Term)
	800-2100	Pressure Transducer 0-100

New Part Numbers

Pricing and Availability

Please contact our sales department for prices and availability.



Standard Probes & Assemblies

OUTDOOR AIR TEMPERATURE SENSOR

Features:

- General purpose outdoor air temperature sensor
- Available in threaded PVC version with rugged weatherproof electrical box
- Easy installation - just threads into mounting hole or standard handy box installation
- Fully potted metal housing protects sensing element and provides fast, accurate temperature sensing
- Cost efficient design
- Sturdy construction - all metal housing with PVC solar shield with optional weatherproof electrical box

Options:

- Sensor values, curves and accuracies
- Alternate configurations for sun shield
- Weatherproof electrical box

Description:

The ATP Outdoor Air Temperature Sensor is designed for use in residential and commercial building automation controls. It features a fast response, precision thermistor sensing element that is totally sealed against the outdoor elements. The PVC sun-shield prevents false readings from direct sunlight. An optional weatherproof electrical box allows for simple installation and provides an extra rugged and reliable sensor for energy management and HVAC applications.



Standard Outdoor Air Temperature Sensor



Outdoor Air Sensor with Weatherproof Box

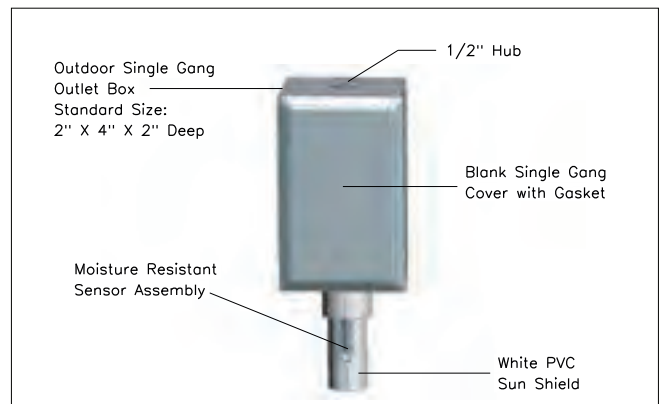
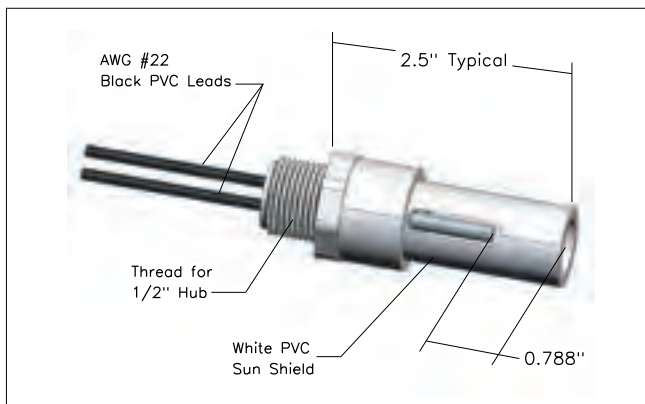

Thermistor Temperature Sensors



ACI/2252 Series
ACI/3K Series
ACI/5K Series
ACI/10K-AN (Type III)
ACI/10K-CP (Type II)



Product Description

The ACI/2252, ACI/3K, ACI/5K, ACI/10K-AN (Type III), and ACI/10K-CP (Type II) Series temperature sensors are thermistor type sensors. These sensors provide a predictable output over a specified temperature range to meet each manufacturer's required input values.

Thermistors offer high accuracy and interchangeability over a wide temperature range.

The thermistors higher resistance relative to Platinum RTD's, creates a larger signal with the same measuring current, negating most lead wire resistance problems and eliminating the need for signal conditioners.

These units are offered in Room, Room with Set Point, Room with Override, Room with Setpoint and Override, and Room w/ Setpoint, Override, and RJ11 Jack, Stainless Steel Duct and Duct without Box, Immersion, Stainless Plate, Raw, Bendable Copper and Stainless Steel Rigid Averaging, Strap-On, Bullet Probe, Button Sensor, and Outdoor Air Configurations.

Setpoint options include a linear 400 Ohm, 1K, 2K, 3K, 5K, 8.5K, 10K, 20K, or 100K slide potentiometer. An optional series resistor allows for any offset of the setpoint potentiometer. These may be either Direct or Reverse Acting.

Indication stickers for setpoint include Cool/Warm, 55 to 85, and 10 to 30°C. Others are available upon request.

Override options include a N/O switch in parallel with the sensor or a separate 2 pole terminal block for Tenant override.

All ACI sensors can be ordered with an optional 4 pin RJ11 or 6 pin RJ12 or 1/8" RS232 Stereo communication jack with terminal blocks for remote programming.

All units come with a two year factory warranty.

Product Specifications

Output	2,252 Ohms @ 77°F(25°C)	Dissipation Constant	3 mW / °C
	3,000 Ohms @ 77°F(25°C)		
Temperature Range	5,000 Ohms @ 77°F(25°C)	Stability	+/-0.13°C
	10K Ohms @ 77°F(25°C) Type II		
	10K Ohms @ 77°F(25°C) Type III		
Interchangeability	-40 to 302°F (-40 to 150°C)	Accuracy	+/- 0.2°C (0 to 70°C)
	+/- 0.2°C (0 to 70°C)	Operating Humidity	0 to 90% RH non-condensing

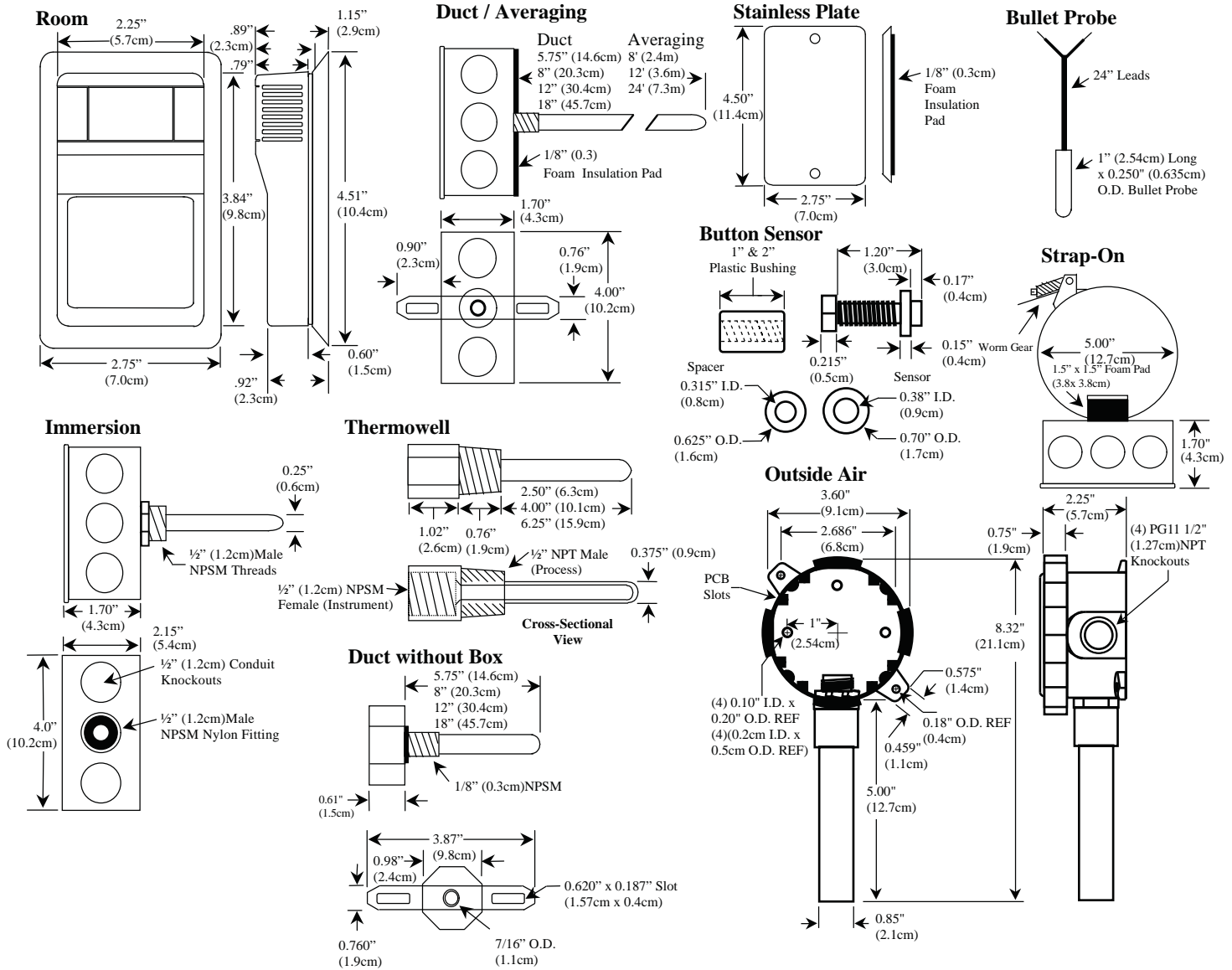

For CE compliance, sensor leads must be no longer than 3 meters in length. Additionally, certain product variations may not be CE compliant.



TEMPERATURE

ALL-PURPOSE THERMISTOR AND RTD SENSORS

ST-A* SERIES

DESCRIPTION

The Precon **ST-A* Series All-Purpose Sensors** provide precision remote temperature sensing for building automation systems and mechanical equipment room instrumentation. The active sensing element is made of a highly stable precision thermistor material or platinum RTDs.

The **ST-A* Series** sensors are rugged, point-sensitive waterproof sensors featuring a 9" (22.8 cm) 304 stainless steel probe and brass fitting. The brass fitting has a 1/2" NPT male thread. The sensors are supplied with two 1/2" locknuts for easy installation in handy boxes (or other enclosures with 1/2" knockouts).

FEATURES

- **Lifetime warranty**
- **$\pm 0.36^{\circ}\text{F}$ ($\pm 0.2^{\circ}\text{C}$) thermistor accuracy**
- **$\pm 1^{\circ}\text{F}$ ($\pm 0.53^{\circ}\text{C}$) RTD accuracy**
- **Wide selection of thermistor and RTD curves**
- **Tip sensitive for precise temperature response**
- **Adaptable with many options**
- **All metal construction with 304 stainless steel probes**
- **Easy to mount to duct, wall, or back box**
- **Waterproof probe**



OPTIONS

- **Custom lengths up to 9' (2.74m)**
- **Matched sensor pairs**
- **Dual sensor probe**
- **NIST traceable**

APPLICATION

The **ST-A* Series** sensors are waterproof and can be used where it is possible for the sensed temperature to fall below the ambient dew point, causing condensation to occur on the sensor. However, it is important that the field connection be made as far as possible from the sensed media. The sensing element is sealed with a thermally conductive compound in a versatile 9" long stainless steel tube with a brass electrical fitting. The all-purpose probe is suitable for plenum mounting, duct mounting, immersion wells, or outside air.

SPECIFICATIONS			
Sensors	Thermistor (thermal resistor) RTD (resistance temperature device)	Sensitivity	See Sensor Resistance Charts in the Technical Reference section
Accuracy		Stability	
Thermistor	$\pm 0.36^{\circ}\text{F}$ (0.2°C)	Thermistor	0.24°F (0.13°C) over five years
RTD	$\pm 1^{\circ}\text{F}$ (0.53°C)	RTD	<0.09°F (0.05°C) over five years
Sensor types available		Heat dissipation	2.7 mW/°C (power needed to raise the temperature by 1°C)
Thermistor @ 77°F	2.252 kΩ, 3 kΩ, 10 kΩ, 20 kΩ, 100 kΩ	Connection	8' (2.4m) of 24 AWG pigtailed with prestripped ends
RTD @ 32°F	Platinum 100Ω, 385 curve Platinum 1000Ω, 385 curve Platinum 1000Ω, 375curve	Mounting	Directly to duct, wall, or customer-supplied back box, no adapters needed for standard boxes
Temp range			
Thermistor	-30° to 230°F (-34° to 110°C)		
RTD	-67° to 240°F (-55° to 115°C)		
Temp response			
Thermistor	Negative temperature coefficient		
RTD	Positive temperature coefficient		



TEMPERATURE

MOUNTING

Locknuts provide direct mounting and can be used where conduit is not required. Mount directly to electrical outlet boxes as shown below.

Basic model comes with two locknuts for mounting to a variety of box options.

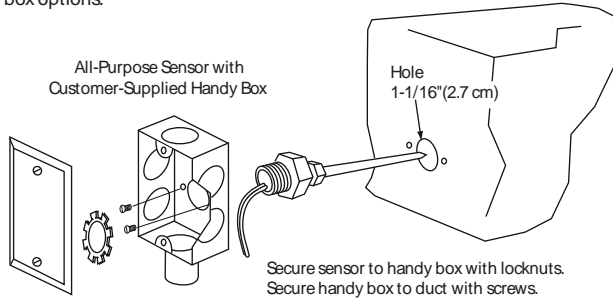

DIMENSIONS

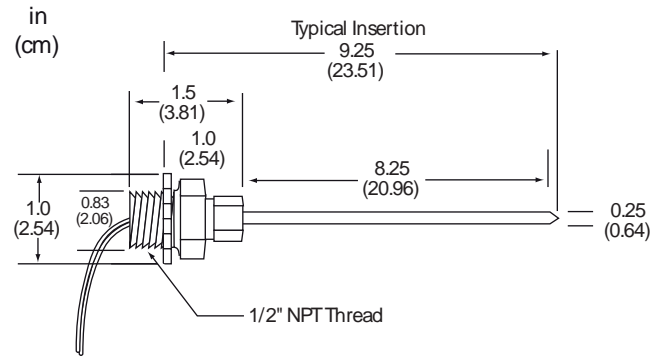

Use the full 8' (2.4m) lead length provided to avoid moisture migration at the field connection.

GREYSTONE

ACCURACY BY DESIGN



RELATIVE HUMIDITY TRANSDUCER



The RH series of Humidity/Temperature Transducer is designed for use with automation, energy management, and process computer control/monitoring systems. Provisions are included for mounting of various temperature sensors.

FEATURES:

- Highly stable RH sensor element
- Humidity span: 0-100%
- Accuracy available 2%, 3%, & 5%
- Choice of precision temperature sensors
- LCD display available
- Field selectable outputs
- AC/DC operation
- Custom logo application

*Peace of mind
through reliable
humidity monitoring*

GREYSTONE HAS AN **ISO 9001** REGISTERED QUALITY SYSTEM

DESCRIPTION: (Humidity transmitter with temperature sensor)

The RH series transducers are intended specifically for use in environmental monitoring and control systems and comes in a variety of enclosures. Its state-of-the-art design combines microprocessor based linearization and temperature correction with a world class capacitance sensor. Reliability and accuracy for even the most critical of measurements.

Excellent long-term stability and quick response time combined with temperature compensation make the RH series transducers an ideal choice in the HVAC market. Various models offer accuracy within 2%, 3%, or 5%.

The RH100 Wall Mount comes in a very compact enclosure which mounts directly to a single electrical box. The RH200 Duct comes standard with a 230 mm (9-inch) stainless steel probe, and an ABS enclosure is provided for wire terminations. The RH300 OSA comes mounted in a weatherproof sun and wind shielded enclosure.

Temperature sensor options of RTD's and thermistors are available in all three configurations.

SPECIFICATION: (Humidity)

System Accuracy:	±2, 3, or 5% RH, 5% to 95% RH
Compensated Temp.:	-40°C to 85°C (-40°F to 185°F)
Sensor Construction:	Thermoset Polymer based capacitive
Protection:	60 micron HDPE cover
Repeatability:	±0.5% RH
Hysteresis:	±1% of span max
Linearity:	±0.5% RH typical
Response Time:	15 seconds @ 25°C
Stability:	±1% RH typical at 50% RH in 5 yrs.
Output Signal Types: (jumper selectable)	4 – 20mA 0 – 1 VDC 0 – 5 VDC 0 – 10 VDC
Power Supply:	18 – 35 VDC at unit (Loop Powered) 18 – 32 VAC nominal ±10% (3-wire)
Wiring Connections:	Screw Terminals (14 to 22 AWG)
Optional Temperature sensor:	100 Ohm RTD, 1000 Ohm RTD, thermistors and transmitters

Note: all output signals are scaled 0-100% RH

RH100B



SPECIFICATION: (Temperature Transmitter)

Supply Voltage:	24VDC/VAC
Output:	4-20mA, 0-5VDC or 0-10VDC
Accuracy:	±0.1% of span
Operating temp:	0°C – 70°C (32°F – 158°F)
OSA operating temp:	-40°C – 85°C (-40°F – 185°F)
Temperature sensor:	1000Ω RTD standard 100Ω RTD optional

RH300A



RH200A c/w LCD option

DESCRIPTION: (Humidity transmitter c/w temperature transmitter)

The RH110, 210, and 310 series of transducers are specifically designed for use in applications where both a temperature and RH signal are required. Each product includes an RH transmitter similar to the RH100, 200 or 300 and also an RTD temperature transmitter conveniently designed onto one PCB to ensure the highest accuracy and reliability available.

The RH110 Wall Mount comes standard in the Designer Space enclosure designed for ease of installation and is available as a 24 VDC loop powered device with both temperature and RH signal outputs. The RH210 Duct Mount features a 9" stainless steel probe with integral 60 micron filter, operates on 24 VAC/DC and is available with either voltage or loop powered current output signals for both temperature and RH. The RH310 OSA transducer is mounted in a compact 4"x4" weatherproof enclosure with integral sun shield and potted sensor assembly. It also operates on 24 VAC/DC with both current and voltage outputs available and includes industrial electronics rated for use from -40°-85°C (-40°-185°F).

SPECIFICATIONS:

These devices feature the same humidity specifications as the RH100, 200 and 300 products, except the output signal types are specified when ordering (not jumper selectable) and note that the RH110 is only available as a DC loop powered device.

The temperature transmitter specifications are also the same as those listed for the RH100, 200 and 300 products except the RH110 is only a DC loop powered device. For all devices, the RH and temperature signals are completely independent from each other.



ISO 9001:2000



Greystone Energy Systems Inc., established in 1983, is one of North America's largest manufacturer of HVAC sensors and transducers for Building Automation Management Systems. We have conscientiously established a worldwide reputation as an industry leader by maintaining leading-edge design technology, prompt technical support, and a commitment to on-time deliveries. We take pride in our Quality Management System which is ISO 9001 certified, assuring our customers of consistent product reliability.

V.06/06

GREYSTONE

ACCURACY BY DESIGN



RELATIVE HUMIDITY TRANSDUCER



The RH series of Humidity/Temperature Transducer is designed for use with automation, energy management, and process computer control/monitoring systems. Provisions are included for mounting of various temperature sensors.

FEATURES:

- Highly stable RH sensor element
- Humidity span: 0-100%
- Accuracy available 2%, 3%, & 5%
- Choice of precision temperature sensors
- LCD display available
- Field selectable outputs
- AC/DC operation

*Peace of mind
through reliable
humidity monitoring*

GREYSTONE HAS AN **ISO 9001** REGISTERED QUALITY SYSTEM

DESCRIPTION: (Humidity transmitter with temperature sensor)

The RH series transducers are intended specifically for use in environmental monitoring and control systems and comes in a variety of enclosures. Its state-of-the-art design combines microprocessor based linearization and temperature correction with a world class capacitance sensor. Reliability and accuracy for even the most critical of measurements.

Excellent long-term stability and quick response time combined with temperature compensation make the RH series transducers an ideal choice in the HVAC market. Various models offer accuracy within 2%, 3%, or 5%.

The RH100 Wall Mount comes in a very compact enclosure which mounts directly to a single electrical box. The RH200 Duct comes standard with a 230 mm (9-inch) stainless steel probe, and an ABS enclosure is provided for wire terminations. The RH300 OSA comes mounted in a weatherproof sun and wind shielded enclosure.

Temperature sensor options of RTD's and thermistors are available in all three configurations.

SPECIFICATION: (Humidity)

System Accuracy:	±2, 3, or 5% RH, 5% to 95% RH
Compensated Temp.:	-40 °C to 85 °C (-40 °F to 185 °F)
Sensor Construction:	Thermoset Polymer based capacitive
Protection:	60 micron HDPE cover
Repeatability:	±0.5% RH
Hysteresis:	±1% of span max
Linearity:	±0.5% RH typical
Response Time:	15 seconds @ 25 °C
Stability:	±1% RH typical at 50% RH in 5 yrs.
Output Signal Types: (jumper selectable)	4 – 20mA 0 – 1 VDC 0 – 5 VDC 0 – 10 VDC
Power Supply:	18 – 35 VDC at unit (Loop Powered) 18 – 32 VAC nominal ±10% (3-wire)
Wiring Connections:	Screw Terminals (14 to 22 AWG)
Optional Temperature sensor:	100 Ohm RTD, 1000 Ohm RTD, thermistors and transmitters

Note: all output signals are scaled 0-100% RH

RH100B



SPECIFICATION: (Temperature Transmitter)

Supply Voltage:	24VDC/VAC
Output:	4-20mA, 0-5VDC or 0-10VDC
Accuracy:	±0.1% of span
Operating temp:	0 °C – 70 °C (32 °F – 158 °F)
OSA operating temp:	-40 °C – 85 °C (-40 °F – 185 °F)
Temperature sensor:	1000Ω RTD standard 100Ω RTD optional

RH300A



RH200A c/w LCD option

DESCRIPTION: (Humidity transmitter c/w temperature transmitter)

The RH110, 210, and 310 series of transducers are specifically designed for use in applications where both a temperature and RH signal are required. Each product includes an RH transmitter similar to the RH100, 200 or 300 and also an RTD temperature transmitter conveniently designed onto one PCB to ensure the highest accuracy and reliability available.

The RH110 Wall Mount comes standard in the Designer Space enclosure designed for ease of installation and is available as a 24 VDC loop powered device with both temperature and RH signal outputs. The RH210 Duct Mount features a 9" stainless steel probe with integral 60 micron filter, operates on 24 VAC/DC and is available with either voltage or loop powered current output signals for both temperature and RH. The RH310 OSA transducer is mounted in a compact 4"x4" weatherproof enclosure with integral sun shield and potted sensor assembly. It also operates on 24 VAC/DC with both current and voltage outputs available and includes industrial electronics rated for use from -40°C to 85°C (-40°F to 185°F).

SPECIFICATIONS:

These devices feature the same humidity specifications as the RH100, 200 and 300 products, except the output signal types are specified when ordering (not jumper selectable) and note that the RH110 is only available as a DC loop powered device.

The temperature transmitter specifications are also the same as those listed for the RH100, 200 and 300 products except the RH110 is only a DC loop powered device. For all devices, the RH and temperature signals are completely independent from each other.



Greystone Energy Systems Inc., established in 1983, is one of North America's largest manufacturer of HVAC sensors and transducers for Building Automation Management Systems. We have conscientiously established a worldwide reputation as an industry leader by maintaining leading-edge design technology, prompt technical support, and a commitment to on-time deliveries. We take pride in our Quality Management System which is ISO

V.06/06

GREYSTONE HAS AN **ISO 9001** REGISTERED QUALITY SYSTEM

SUBMITTAL

Outside Air Humidity Transducer



Part Number:

The RH300 series uses a highly accurate and reliable Thermoset Polymer based capacitance humidity sensor and state-of-the-art digital linearization and temperature compensated circuitry to monitor humidity levels. A 60 micron HDPE filter protects the sensor for contaminants. The hinged, gasketed, weatherproof ABS enclosure or the round, weatherproof ABS enclosure provides ease of installation and protection from the elements.

Sensor Type	Thermoset Polymer based capacitive
Range	0 to 100% RH
Accuracy	±2, 3, or 5% RH (5 to 95% RH)
Response	15 Seconds typical
Stability	±1% RH typical @ 50% RH in 5 years
Operating Temperature	-40 to 70 °C (-40 to 158 °F)
Power Supply	18 to 30 Vdc, 15 to 26 Vac
Output Signal	Jumper-selectable 4-20 mA current loop 0-1, 0-5, or 0-10 Vdc
Consumption	22 mA maximum
Optional Temperature Sensor	Various RTDs and thermistors available as 2 wire resistance output (See ordering chart)
Enclosure	ABS - Nema 4 (IP65) - Weatherproof
Wiring Connections	Screw terminal block (14 to 22 AWG)

Installation:

For complete installation and wiring details, please refer to the product installation instructions.

The RH300 should be mounted on an outside North facing wall, under the eaves which will provide protection from direct sunlight and wind.

The RH300 can be mounted directly to buildings wall face using the provided mounting holes. There are 0.85" holes for conduit connection.

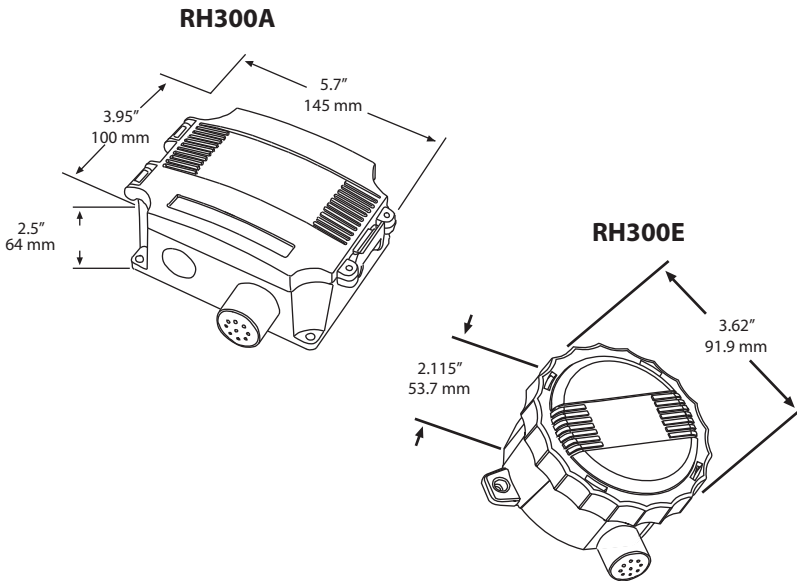
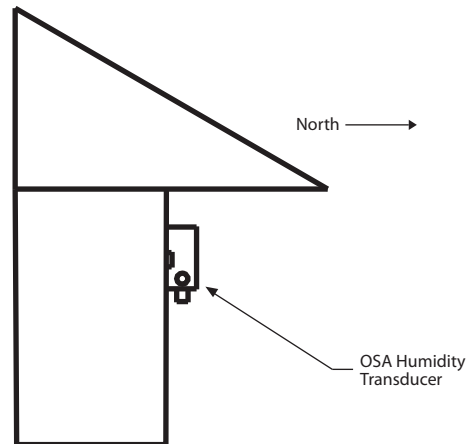

GMT220 Series Carbon Dioxide Transmitters for Harsh and Humid Industrial Applications



Vaisala CARBOCAP® Carbon Dioxide Transmitter Series GMT220 withstand harsh and humid environments.

The Vaisala CARBOCAP® Carbon Dioxide Transmitter Series GMT220 is designed to measure carbon dioxide in harsh and humid environments. The housing is dust and waterproof to IP65 (NEMA 4) standards. The materials have been chosen for good corrosion resistance.

High-end measurement technology

The GMT220 series incorporate the advanced Vaisala CARBOCAP® Sensor. The patented sensor has unique reference measurement capabilities. Its critical parts are made of silicon; this gives the sensor outstanding stability over both time and temperature. By lengthening the time between calibration intervals, the user saves both time and money.

Optimal measurement range for each application

The user has a choice of measurement ranges up to 20 % CO₂; the GMT221 for higher concentrations of CO₂ and the

GMT222 for lower concentrations of CO₂. The transmitter can be connected to various measurement systems. In addition to standard analog, voltage and current outputs, there are also two configurable alarm relay outputs. Activated relays are indicated by LED lights on the cover. An optional LonWorks® digital interface is also available.

Interchangeable probes

The GMT220 probes are truly interchangeable. They can be removed and reattached or replaced at any time – without the need for calibration and adjustment. The probes can be attached directly to the transmitter body or, when used with a cable, installed remotely into hard-to-reach places or areas with dangerously high levels of CO₂.

Simple installation

A separate mounting plate makes installing the transmitter easy - simply attach the mounting plate to the wall and lock the transmitter body in place.

Features/Benefits

- Incorporates Vaisala CARBOCAP® Sensor - the silicon-based NDIR sensor
- IP65 (NEMA 4) protected against dust and spray water
- Choice of several measurement ranges
- Easy installation
- Interchangeable probes – easy maintenance

Applications

- Horticulture and fruit storage
- Greenhouses and mushroom farming
- Safety alarming and leakage monitoring
- Demand controlled ventilation in harsh environments

Easy field maintenance

Since the probes of the GMT220 transmitters are truly interchangeable, they facilitate easy field maintenance.

The probes can either be replaced with newly calibrated probes or with separate probes that are only used as a reference for calibration checking. This minimizes downtime. The end user can do field maintenance without any additional equipment or heavy and expensive calibration gas bottles. Any replaced probes can be sent to Vaisala for recalibration.

The Vaisala CARBOCAP® Hand-Held Carbon Dioxide Meter GM70 is ideal for field verification and/or calibration.



Technical Data

General

Measurement Ranges	
GMT221	0...2% CO ₂ 0...3% CO ₂ 0...5% CO ₂ 0...10% CO ₂ 0...20% CO ₂
GMT222	0...2000 ppm 0...3000 ppm 0...5000 ppm 0...7000 ppm 0...10 000 ppm
Accuracy at +25 °C (+77 °F) against certified factory references	
GMT221	<±[0.02% CO ₂ + 2% of reading]
GMT222	<±[20 ppm CO ₂ + 2% of reading]
(incl. repeatability and calibration uncertainty)	
Nonlinearity	<±1.0 %FS
Temperature dependence of output (typical value)	0.1 %FS /°C (±0.05 %FS /°F)
Pressure dependence (typ.)	0.15% of reading/hPa
Long-term stability	<±5 %FS/2 years
Response time (63%)	
GMT221	20 seconds
GMT222	30 seconds

GMT221/222

Analog output signals	0...20 or 4...20 mA and 0...10 V
Resolution of analog outputs	0.03 %FS
Recommended external load:	
current output	max. 400 Ohm
voltage output	min. 1 kOhm
Two pre-or user-defined relay outputs	
Relay contacts	max. 30VAC/60VDC, 0.5A
Power supply	nominal 24 VAC/DC
Power consumption	<4 W
Warm-up time	30 seconds
Operating temperature range	15 minutes full specifications
display	-20...+60 °C (-4...+140 °F)
Storage temperature range	0...+50 °C (+32...+122 °F)
Operating humidity range	-30...+70 °C (-22...+158 °F)
	0...100 %RH
	non-condensing
Housing material	
transmitter body	ABS plastic
probe	PC plastic
Housing classification	IP65 (NEMA 4)
Weight:	
GMT221	max. 280 g
GMT222	max. 300 g
Probe cable length	2 m and 10 m (optional)

Accessories

GMP221, GMP222	spare probe
(use the order form to define measurement range etc.)	
25245GM	clips (2 pcs) for attaching the probe
GM45156	mounting flange for the probe
25665GMSP	2.0 m probe cable
210848GMSP	10.0 m probe cable

GMK220	calibration kit for interchangeable probes
19040GM	serial COM adapter for maintenance purposes
26150GM	chamber for pump aspirated sampling systems
GM70	Hand-held CO ₂ meter for field verification and calibration

Electromagnetic compatibility

Complies with EMC standard EN61326-1:1997 + Am1:1998 + Am2:2001; Generic Environment.

Dimensions

Dimensions in mm (inches)

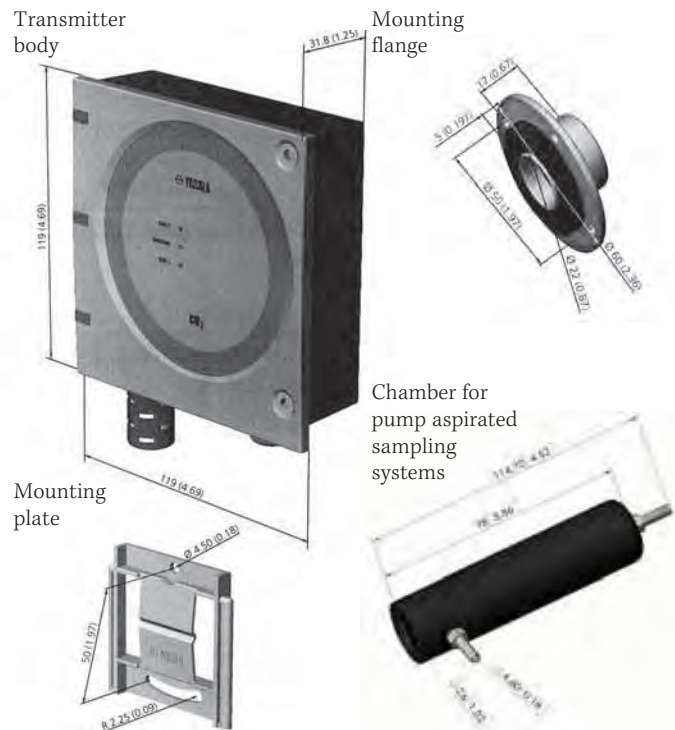

GMP221

GMP222



CARBONCAP® is a registered trademark of Vaisala.
Specifications subject to change without prior notice.
©Vaisala Oyj



VERIS CX SERIES CALIBRATION INSTRUCTIONS



PREPARATION

1. Make sure unit to be calibrated has been properly installed and has been operating for at least one hour.
2. Use only Veris Industries calibration kit model C-500. Zero calibration is performed with Nitrogen gas. Span calibration is performed with 2000ppm CO2 gas. A flow regulator is required to limit gas flow to <1 lpm. Exceeding this flow rate may cause calibration errors.

SETUP

1. Install tubing to regulator and screw regulator on gas bottle.
2. Remove front cover from unit and locate plastic barb fitting and menu pushbuttons. A label indicating pushbutton functions is located inside front cover plate.
3. Attach tubing firmly to barb fitting.

CALIBRATION

1. Press ENTER button to enter configuration mode.
2. Press ENTER repeatedly until CO2 CAL menu option appears on the display:

CO2	CAL ?
* YES	NO

3. Press “+” to select YES option.

4. Using “+/-” buttons, select ZERO or SPAN calibration. Press ENTER to continue.

NOTE: C-500 kit includes Nitrogen gas for zero calibration ONLY. In most applications, span calibration is not required. Consult factory for optional span gas. Always perform ZERO calibration first!

* ZERO	
SPAN	

5. Verify display indicates appropriate calibration and gas concentration (0ppm for ZERO / 2000ppm for SPAN) Press ENTER to continue.

ZERO	GAS
0	PPM

6. Display should prompt to flow gas:

FLOW	GAS
* START	

Open regulator valve and adjust pressure to 7PSI. This will produce the appropriate flow rate. Press ENTER to begin countdown timer.

CAL	TIME
* 420	SEC

7. Wait for countdown timer to reach zero, and for display to indicate calibration is complete:

	DONE
STOP	GAS

8. Close regulator valve and disconnect tubing from unit. Press ENTER to return to normal operation.

9. Replace sensor cover.

GE Sensing

Features

- Patented Absorption Infrared/Gas sensing engine provides high accuracy in a compact low cost package.
- Patented ABC Logic™ self-calibration system eliminates the need for manual calibration in most applications.
- Mounting bracket with terminal block provides quick, easy wiring.
- Gas permeable, water resistant diffusion filter prevents particulate and water contamination of the sensor.
- Locking screw secures cover and sensor to the mounting bracket for tamper resistance.
- Dual simultaneous analog output (V & mA).
- On board relay with adjustable setpoint and dead-band.
- Choice of nine pre-programmed “standard settings” on easy-to-use interface.
- PC interface and adjustable settings allow for simple configuration.
- Optional enclosures available.
- Thirteen minute one-step calibration process.
- Lifetime calibration guarantee.

Telaire Duct Mount

Telaire Ventostat® Duct/In-Duct Mount CO2 Ventilation Controllers

Telaire Duct Mount is a Telaire product. Telaire has joined other GE high-technology sensing businesses under a new name—GE Industrial, Sensing.



GE Sensing

Applications using a duct mounted sensor enable one sensor to control one air handling zone. Two sensor mounting configurations are available, "in-duct" and "remote" duct mount. For in-duct, the sensor (8001B, 8002B, or 8102B) is mounted inside the duct. Remote duct mount enables the user to mount the sensor (8007, 8008 or 8009) remotely with use of the pitot sampling tube. All in-duct sensors are compatible with accessory enclosures.

The Ventostat controller offers an SPDT relay (normally open or closed) and can be custom-programmed to a specific measurement and output range using the UIP software interface or on-board keypad (display units).

ABC Logic Self Calibration Program

CO2 controllers use the patented ABC (Automatic Background Calibration) Logic self-calibration system that virtually eliminates the need for manual calibration in applications where the indoor CO2 level drops to outside levels during unoccupied periods (e.g. during evening hours). ABC Logic is a special software routine in the sensor that remembers the background readings for 14 consecutive evenings and calculates if there is sensor drift, then corrects for it. ABC Logic will not work properly in applications where the space is unoccupied for less than four hours a day or where there are industrial sources of CO2 in the building, such as breweries or wineries.

Fast One-Step Calibration

The CO2 Sensors (except the 8009) feature a fast one-step calibration process should it ever be required. A zero calibration can be performed in less than fifteen minutes by flowing gas to the calibration port and activating the calibration routine. If drift occurs in the sensor, it usually affects the zero setting of the sensor only. If a two point calibration is desired, it can be performed using the UIP Program.

Lifetime Calibration Guarantee

Telaire is serious about minimizing maintenance so each sensor, comes with a lifetime calibration guarantee. If a Telaire 8000 sensor drifts out of calibration range, it can be sent back to Telaire for a free factory calibration. Further information on the guarantee is available on our web site.

User Interface Program (UIP)

All Ventostat 8000 (except the 8009) series controllers can be connected to a PC using the UIP 2072 Windows® program. Simply connect to the sensor using the onboard RJ45 jack and you can adjust the output scaling, elevation adjustment, relay setpoint, relay dead-band, select linear or proportional exponential output, perform single-point or two-point calibration, and check ppm levels. Display units can also be adjusted using the keypad.

Ventostat 8001B/8002B

Ventostat 8001B CO2 Sensor/No Display

Ventostat 8002B CO2 Sensor/With Display

In-Duct Mount for use in commercial buildings for demand controlled ventilation. The sensor can also be used as a wall mount. Conformal coated electronics and a high temperature enclosure (UL94-5 V) allow installation in harsh environments. Model 8002B includes a display and a keypad for sensor programming without software.

Ventostat 8102B

Ventostat 8102B CO2 Sensor/With Display

Equipped with a dual beam sensor, the unit provides higher accuracy and stability over time. In-Duct Mount is for use in commercial buildings. The display and keypad allow for sensor programming without software. Conformal coated electronics and a high temperature enclosure (UL94-5 V) allow for installation in harsh environments.

Ventostat 8007/8008

Ventostat 8007 CO2 Sensor/No Display

Ventostat 8008 CO2 Sensor/No Display

Pitot tube configuration - the pitot tube is installed in the duct and the sensor is mounted remotely, which allows for easy access.

Ventostat 8009

Ventostat 8009 CO2 Sensor

This duct mount includes our patented technology but omits programming ability, which allows for an economically priced sensor. It includes pitot tube configuration and a calibration guarantee.

Duct Mount Specifications

Sensing Method

- Non-dispersive infrared (NDIR) absorption
- Gold-plated optics
- Patented ABC Logic self calibration algorithm

Sample Method

- 8001B/8002B/8102B - Diffusion
- 8007/8008/8009 - Flow Through

Measurement Range

0 to 2000 ppm factory default
Adjustable to 10,000 ppm

Accuracy

±40 ppm +3% of reading
@72°F (22°C) when compared against a certified factory reference*

Non Linearity

< 1% of FS

Stability

< 2% of FS over life of sensor (15 year typical)*

Temperature Dependence

±0.11% per °F (±0.2% FS per °C)

Pressure Dependence

0.13% of reading per mm Hg

Response Time

- 8001B/8002B/8102B < two minutes for 90% step change
- 8007/8008/8009 < three minutes for 90% step change typical

Warm-up Time

- < Two minutes (operational)
- 10 minutes (for maximum accuracy)

Operating Conditions

- 32°F to 122°F (0°C to 50°C)
- 0 to 95% RH, non-condensing

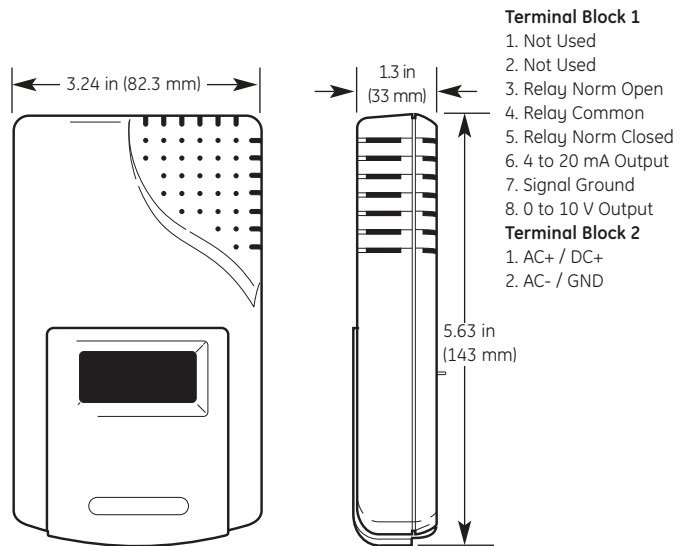

Terminal Block 1

1. Not Used
2. Not Used
3. Relay Norm Open
4. Relay Common
5. Relay Norm Closed
6. 4 to 20 mA Output
7. Signal Ground
8. 0 to 10 V Output

Terminal Block 2

1. AC+ / DC+
2. AC- / GND

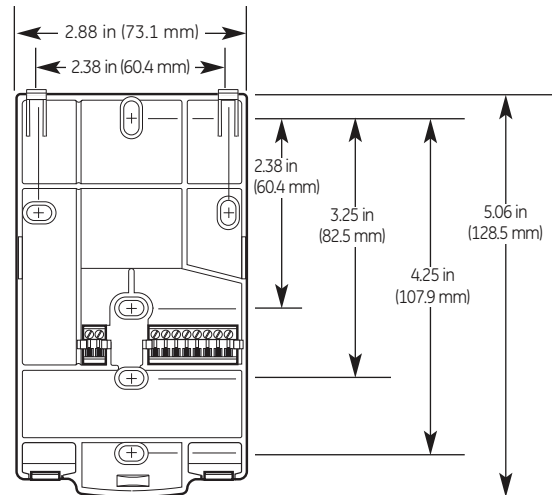

Ventostat 8100/8000 dimensions

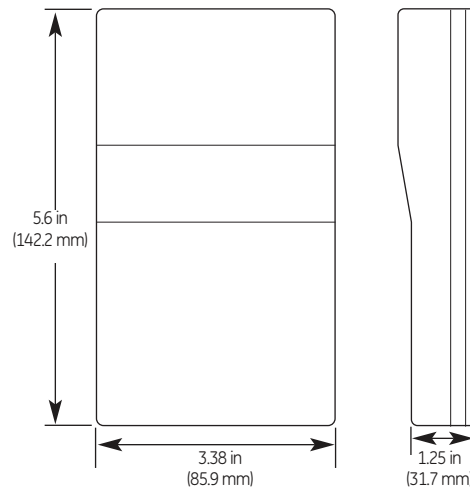

Ventostat 8009 dimensions

Connections

Removable Screw Terminal (18-22 AWG wire)

1. Vout (Analog 0 to 10 V output)
2. Gnd (Ground)
3. Vin (24 VAC (+))

Duct Mount Specifications

Storage Conditions

-4°F to 158°F (-20°C to 70°C)

Calibration Interval

- Not required
- Lifetime calibration guarantee

Output

Analog

- 0 to 10 V (100Ω output impedance) and
- 4 to 20 mA (RL maximum 500Ω) available simultaneously (4 to 20 mA not available on the 8009)

Relay

SPDT, gold bifurcated, 2 A maximum @ 24 V (Not available on the 8009)

Relay threshold 1000 ppm, dead band 50 ppm (factory set) User configurable (Not available on the 8009)

Digital

RS232 communicates with Telaire CO2 View and UIP software (Not available on the 8009.)

**Sensor employs Automatic Background Calibration (ABC) Logic a patented self-calibration technique used in applications where concentrations will drop to outside ambient conditions (approximately 400 ppm) at least three times in a 14 day period, typically during unoccupied intervals. Specified accuracy is achieved after 14 days of continuous operation.*

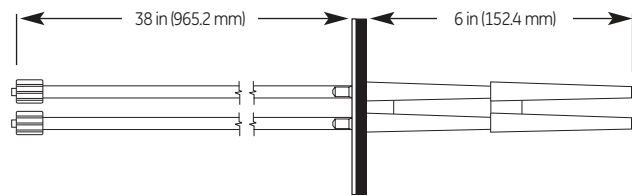
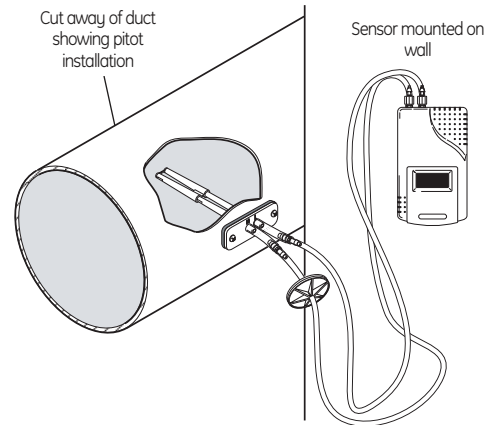

Ventostat 8007/8008 Pitot Mounting Configuration

Accessories

8001B, 8002B, 8102B

- 1505 Water Resistant Enclosure for Harsh Environments
- 1551 Outside Air Enclosure for Temperatures to -20°F (-29°C)
- 1508 Aspiration Box for Duct Mounting

8001B, 8002B, 8102B, 8007, 8008

- 2072 UIP for Customizing Settings and Calibration
- 2075 Calibration Kit for Performing Zero and Span Calibration.
- Replacement Bottles for Replacing 2075 Gas Bottles



©2006 GE. All rights reserved.
920-358A

All specifications are subject to change for product improvement without notice. GE® is a registered trademark of General Electric Co. Other company or product names mentioned in this document may be trademarks or registered trademarks of their respective companies, which are not affiliated with GE.

Installing the Sensor

!WARNING!

Before performing service or maintenance operations on the systems, turn OFF main power switches to the unit. Electric shock can cause personal injury. Please read and follow the wiring instructions precisely; miswiring may cause permanent damage to the product.

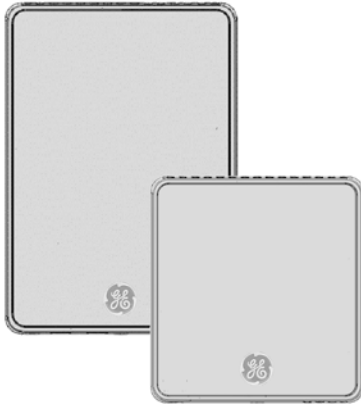

Basic Installation for Non-Display Units

1. Separate the case into its front and rear sections.
2. Secure the rear section of the case to the wall or junction box using the supplied screws, and make necessary wire connections.
3. Mount the Controller on the base by aligning the top clips and then securing to the bottom clips. Secure the Ventostat with the supplied set screw. A one-minute stabilization warmup will take place.

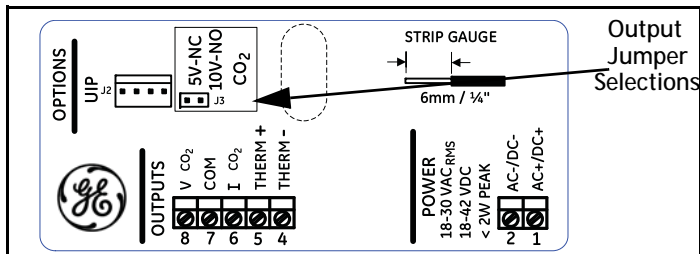

Internal Label for Non-Display Units

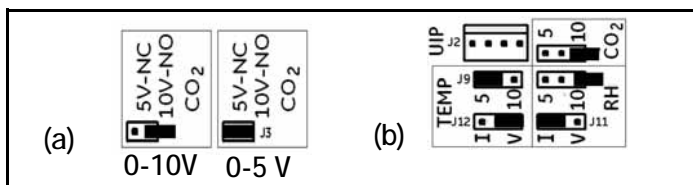

Jumper Settings for Non-Display (a) and Display (b) Units

Note: Example b shows outputs of CO₂ — 4-20 mA and CO₂ — 0-10 V, humidity — 4-20 mA, and active temperature — 0-5 V.

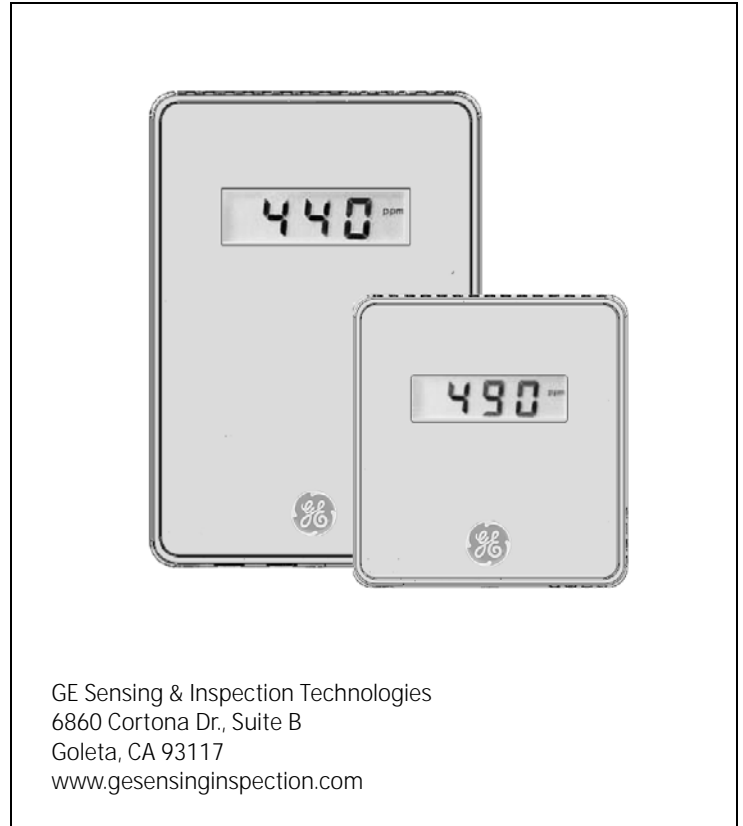

Basic Installation for Display Units

1. Separate the case into its front and rear sections.
2. Secure the rear section of the case to the wall or junction box using the supplied screws, and make necessary wire connections.
3. Mount the Controller on the base by aligning the top clips and then securing to the bottom clips. Secure the Ventostat with the supplied set screw. A one-minute stabilization warmup will take place.
4. When fitting the T8300 (pitot tube version), complete the installation by screwing the tube connectors to the input ports on the sensor. The tubing connectors can be attached to either input port. It will not affect the performance of the sensor. (See page 3 for further instructions.)

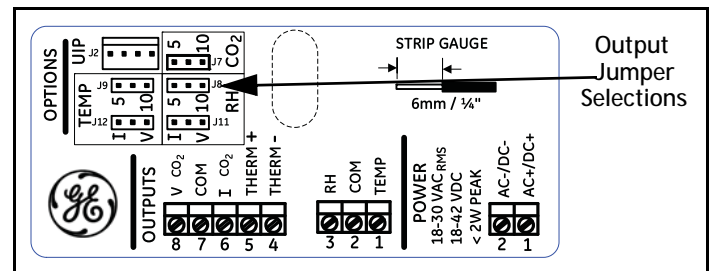

Internal Label for Display Units

Ventostat Wiring Diagrams

The Ventostat family of products has two basic configurations. One configuration provides three active outputs (CO₂, RH and temperature) and an independent thermistor. It has an output terminal block with pins #1, 2 and 3. The other configuration provides only CO₂ outputs and an independent thermistor and has no terminal block with pins 1, 2, and 3 installed. For electrical wiring and power supply requirements, these two configurations are identical; please follow the specific instructions for wiring. The recommended wire gauge is 18-22 AWG (1.0 to 0.75 metric).

!WARNING!

Ventostat products have three terminal pins that are connected inside the sensor to a common/ground: pin #2, 5 and 7 on the I/O terminal blocks and pin #2 on the power block. Do NOT connect positive (hot) 24 VAC power line to terminal number 2 of the terminal block.

Caution!

The T8100 Ventostats are either 3-wire or 4-wire type configurations, powered by either AC or DC voltage. They are not 2-wire or loop-powered devices. Wiring the units as 2-wire or loop-powered devices will irreparably damage the sensors and void the warranty.

Note: For temperature measurements, Ventostat models contain a passive thermistor (terminal pins #4 and 5), which is electrically isolated from the other circuitry and should be wired independently from active CO₂/RH/temperature outputs. The thermistor has no connection to the Ventostat common ground and/or power. The active temperature output has the same common (ground) as CO₂ and RH outputs.

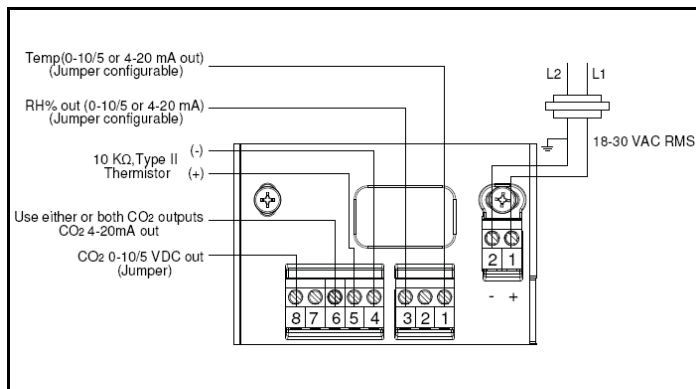

Figure 1: Display Unit Wiring for 3-Wire System, AC Power

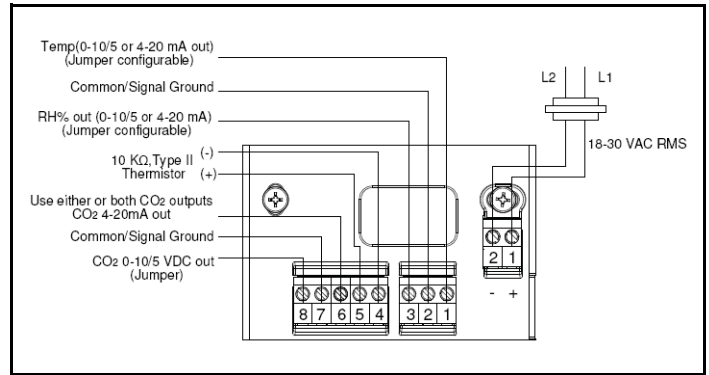

Figure 2: Display Unit Wiring for 4-Wire System, AC Power

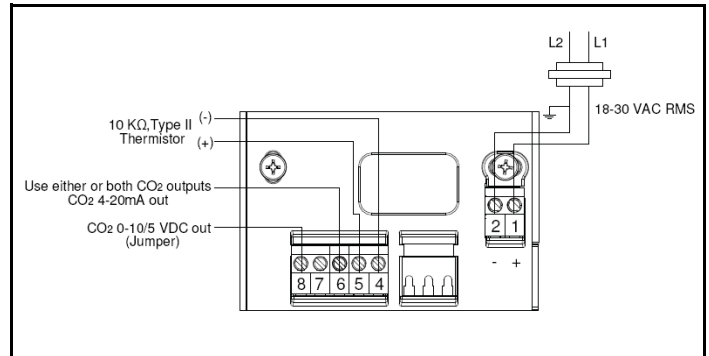

Figure 3: Non-Display Unit Wiring for 3-Wire System, AC Power

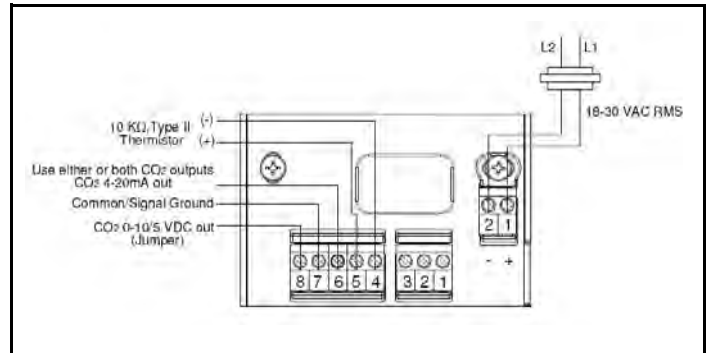

Figure 4: Non-Display Unit Wiring for 4-Wire System, AC Power

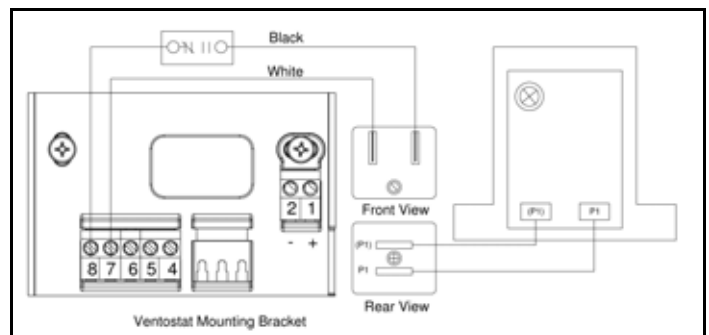

Figure 5: Wiring CO₂ Sensor Voltage Output to Honeywell M7415 Damper Actuator with W7459 Logic Module

Sensing Duct CO₂ Concentrations

Duct-Mounting the Enclosures

Ventostat products can be installed inside the return air ductwork, if needed. As an alternative, please consider the T8031 unit. When mounting these products inside the ductwork, seal the hole around the wires and leave the duct insulation in place to prevent condensation which may damage the sensor.

Pitot Tube Installation for T8300 and T8300-D

Install the mounting bracket, then install the pitot tube assembly as follows:

Note: *The length of the Tygon® tubing is 6 ft. (1.8 m) with the optional T62892 pitot kit for the T8300. In order to maintain optimum accuracy, the tubing should not be lengthened. If the sensor is mounted closer than 3 ft. (0.9 m) the excess tubing should be shortened to avoid interference with mechanical or moving devices.*

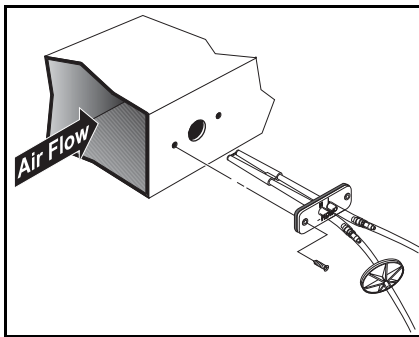

1. To mount the pitot tube, drill one 7/8" hole through the duct.
2. Insert the pitot tube and mark the two remaining holes for the mounting screws.
3. Punch or drill the two marked holes.
4. Note the direction of airflow in the duct.
5. Note the marking on the pitot tube flange and insert so that it is properly aligned with the airflow.
6. To ensure an air tight seal, make sure the mounting surface of the duct is clear of dirt or obstructions. Then, attach the pitot tube to the duct with sheet metal screws or rivets.
7. Check the length of the tubing before attaching to the sensor. The tubing should connect without stretching or pulling. If the length is long enough to create a loop or bind in the tubing, it should be shortened.
8. To shorten the tubing, remove the connectors that attach to the sensor and cut the tubing to length.
9. Replace the tubing connectors by using a twisting or screwing motion. Verify the connection is secure.

Note: *If the tubing length has been shortened, be sure the in-line filter is replaced on the pitot tube connector marked with an "H".*

Accessory Enclosures

Model 1508 Duct Mount Enclosure (Aspiration Box)

The T8100/T8200/T8300 units can be installed inside a Model 1508 Duct Mount Enclosure.

Model 1551 Outside Air Measurement Enclosure

This NEMA-3R weatherproof enclosure includes thermostat and allows installing the sensor in environments with temperatures down to -40°F.

Model 1505 Harsh Environment Enclosure

For extreme environments where the sensor might be subjected to condensation or water spray such as those found in greenhouses or breweries- NEMA-3R rated.

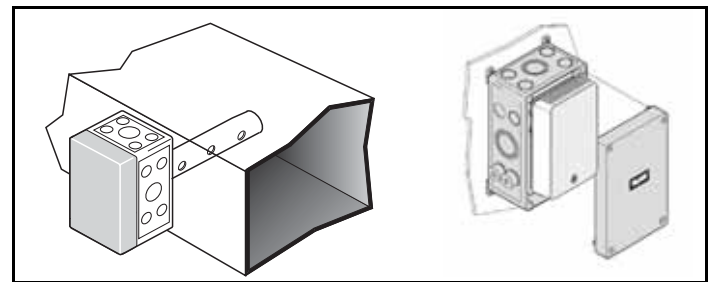

Ventostat Specifications

Sensing Method

Non-dispersive infrared (NDIR) absorption
Gold-plated optics
Patented ABC Logic self calibration algorithm

CO₂ Measurement Range

T8100/T8300 - Single Channel: 0 to 2000 ppm
(0 ppm = 0 V, 4 mA)

T8200 - Dual Channel: 0 to 2000 ppm
(0 ppm = 0 V, 4 mA)

CO₂ Accuracy

T8100/T8300 - Single Channel
400-1250 ppm ±30 ppm or 3% of reading, whichever is greater*,**
1250-2000 ppm ±5% of reading + 30ppm *,**

T8200 - Dual Channel
75 ppm or 10% of reading (whichever is greater)

*Tolerance based on span gas of ±2%
** ABC Logic not deactivated

Power Supply Requirements

18-30 VAC RMS 50/60 Hz

Power Consumption

Typical 0.7 W at nominal voltage of 24V AC RMS

Temperature Dependence

0.2% FS per °C ($\pm 0.11\%$ per °F)

Stability

T8100/T8300 - Single Channel
<2% of FS over life of sensor (15 years)

T8200 - Dual Channel
<5% of FS or <10% reading annual over life of sensor (10 years)

Pressure Dependence

0.135% of reading per mm Hg

Certifications

CE and RoHS compliant

Signal Update

Every 5 seconds

CO₂ Warm-up Time

< 2 minutes (operational)
10 minutes (maximum accuracy)

Operating Conditions

32°F to 122°F (0°C to 50°C)
0 to 95% RH, non-condensing

Storage Conditions

-40°F to 158°F (-40°C to 70°C)

Flammability Classification

UL94 5VA

Thermistor Type

NTC 10 K Ω thermistor

Thermistor Accuracy

$\pm 1^\circ\text{C}$ (15° to 35°C)

RH Sensing Element

Capacitive polymer sensor

RH Range

0% to 99% RH (non-condensing)

RH Accuracy (25°C)

$\pm 2.5\%$ RH (20 to 80% RH)
 $\pm 3.5\%$ RH (<20% and >80% RH)

Active Temperature Accuracy

$\pm 0.8^\circ\text{C}$ @ 22°C

Active Temperature Range

0 to 50°C

ABC Logic™ Self Calibration System

ABC Logic™ (Automatic Background Calibration) self calibration allows the sensor to continually recalibrate itself when the indoor concentrations drop to outside levels while the building is unoccupied. Generally a building must be regularly unoccupied for 4 hours or more for this self-calibration system to operate properly. Under these conditions, ABC Logic™ should maintain sensor calibration over the lifetime of the sensor. The ABC Logic™ should be turned OFF where a building is continuously occupied 24 hours per day, or where there could be significant sources of non-occupant related CO₂ such as greenhouses, breweries and other industrial and food processing applications.

Output

Analog

0 to 5 V, (100 Ω output impedance)
0 to 10 V (100 Ω output impedance) and
4 to 20mA (R_L maximum 500 Ω) available simultaneously for CO₂
output
Digital to analog error $\pm 1\%$

Warranty/Other

Warranty

18 months parts and labor

This product is covered by one or more of the following patents:
5,650,624 / 5,721,430 / 5,444,249 / 5,747,808 / 5,834,777 / 5,163,332 /
5,340,986 / 5,502,308 / 6,344,798 / 6,023,069 / 5,370,114 / 5,601,079 /
5,691,704 / 5,767,776 / 5,966,077 / 6,107,925 / 5,798,700 / 5,945,924 /
5,592,147 / 6,255,653 / 6,250,133 / 6,285,290

Warranty Repairs

GE Sensing will repair Telaire product that fails to meet the terms provided for in the Return and Warranty Policy Statement (See, <http://www.gesensing.com/service/brochures.htm>). Warranty period shall start from date of manufacture and be based on product category and type of equipment as specified in Table 1: Product Warranty Periods. For all warranty repairs, GE Sensing will bear all product repair parts, labor, and standard ground shipping charges.



Vaporstat™ Model 9002

Infrared Absolute Humidity Sensor

Measures Dewpoint or Absolute Humidity / Mixing Ratio

Operating/Installation Manual

Applications

The Vaporstat™ is the first of a new generation of low-cost, commercially available humidity sensing devices that directly measure dew point or absolute humidity. Dew point and absolute humidity measurements directly correspond to the absolute amount of water vapor in the air, and are not temperature-dependent like relative humidity. The Vaporstat™ has measurement characteristics similar to chilled mirror hygrometers, but at a fraction of the cost and with considerably less adjustment and maintenance.

The Vaporstat™ can be used in any application where it is necessary to monitor or control moisture levels in outdoor or indoor ambient conditions, particularly where temperatures may vary within a space or in the air delivered to a space.

Recommended Uses Include:

- Desiccant system control (space and process) for manufacturing and retail applications
- Humidification/dehumidification control in a variety of applications
- Economizer/mixed-air control on air handlers and rooftop A/C units
- Monitoring and control to avoid mold and mildew conditions

Key Features

- Directly measures dew point or absolute humidity
- Measurement provided in °F dew point
- Telaire's patented Absorption Infrared™ technology provides high accuracy in a compact and low cost package
- Gold-plated optical sensing element increases sensor life and durability
- Easily calibrated in field using dry nitrogen gas or a reference sensor
- Dual simultaneous analog outputs: 0-10 volts and 4-20 milliamperes
- Relay (normally open or closed) with adjustable set point and hysteresis (dead band)
- On-board altitude correction (set via keypad)
- Conformal-coated electronics to insure durability in harsh climates
- Tamper resistant cover protects keypad and allows for visible or hidden display
- Utilizes Telaire's standard accessory enclosures for duct mounting or outside mounting

Low Cost Infrared Humidity Measurement

Infrared hygrometers have traditionally been used in high-end scientific and meteorological applications for accurate measurements of absolute humidity. Telaire has applied its low-cost infrared gas-sensing platform to measure water vapor, making Vaporstat™ the first direct measuring water vapor sensor available as a commercial instrument for HVAC and industrial applications.

Traditional measurement of humidity uses technology that relies on some physical or chemical interaction with the water being measured. RH sensors that use capacitive or polymer sensors depend on water in the air being absorbed into a thin film material, which changes its resistance depending on the water content. Changing concentrations of water vapor can cause changes in the sensor over time that may affect accuracy and cause drift. Also, when exposed to levels near saturation (95-100% RH), they can become inaccurate and be rendered non-functional. Other contaminants in the air may also have unwanted effects on sensor stability, accuracy or useful life.

Infrared-based water vapor measurement is "non-interactive" in nature. Infrared measurement does not depend on physical or chemical interaction with the sensor element. Telaire's Vaporstat™ sensor works on the principle that water vapor absorbs infrared light at a specific wavelength. The Vaporstat™ simply pulses infrared light through a sample of air and measures the amount of that light being absorbed by water molecules. The infrared detector undergoes no physical or chemical interaction, and because the sensor is slightly heated by the infrared source, it can measure concentrations at saturation levels.

1. Introduction

The Vaporstat™ represents the first infrared-based hygrometer for measurement applications in the range of 0 to 80 °F dew point. The sensor package is designed for wall mounting. Telaire also makes standard enclosures that allow the Vaporstat™ to be mounted in a variety of applications including aspirated sampling of in-duct concentrations, outside air measurement and measurement in wet environments.

This manual covers installation, wiring and adjustment of the sensor and provides conversion information to translate the dew point measurement of the sensor to other measurements of humidity, including grains/lb and relative humidity.

2. Specifications

Measurement Method

Non-Dispersive Infrared (NDIR), Dual-Channel, Non-Interactive, Non-Saturating

Sensor Output Units

°F dew point

Measurement Range

0°F to 80°F dew point (-18°C to 27°C dew point)

Typical Dew Point Accuracy @ 77°F (25°C), 26°F to 80°F DP Range (-3 to 27°C DP)

(As measured against a factory certified reference):
±3.6°F (2°C) dew point

Altitude Correction

User adjustable in 500 ft. increments using keypad

Operating Temperature Range

Room & Duct
32°F to 120°F (0°C to 49°C), 1508 enclosure required for duct mounting

Outdoor

-20°F to 120°F (-29°C to 49°C), when installed in 1551 enclosure

Storage Temperature:

14°F to 170°F, (-10°C to 77°C)

Input Power:

18 – 30 VAC, 50/60Hz (half wave rectified)

18 – 42 VDC

1.75 VA average, 2.75 VA peak

Analog Outputs (available simultaneously):

0-10 V DC (100 Ohm output impedance)

4 – 20 mA (RL_{max} – 500 Ohms)

Relay Output:

- Normally open and normally closed (SPDT)

- Gold Bifurcated, 2A max @ 24 V

On Board Keypad Adjustments:

- Select °F dew point output and display

- Measurement range

- Analog output range

- Zero concentration calibration (using nitrogen gas)

- Calibration to ambient air

- Relay set point

- Relay hysteresis (dead band)

Limited Warranty:

18 months (see warranty card for details)

Sensor Rated Life:

15 years

Installation:

- Wall

- Duct with aspiration box (model 1508)

- Outside air with enclosure (model 1551)

Accessories

2076 Calibration Kit

Field Calibration

The Vaporstat™ features a dual-beam optical assembly that utilizes a neutral reference measurement to adjust for minute changes that may occur in the optics. Although this feature will minimize sensor drift, field calibration at sensor installation and subsequent periodic calibration is still recommended to maintain optimum accuracy.

Each sensor has an individually developed curve, based on a certified chilled mirror hygrometer, with over 8 calibration points. This individualized curve is stored in the sensor's permanent memory and is valid for the life of the sensor. Using a reference device to field calibrate the sensor at a known concentration re-establishes its original calibration accuracy. Reference devices include:

- A calibrated, reference dew point sensor
- Dry nitrogen gas, flowed through the sensor (Telaire Calibration Kit 2076)

3. Dimensional Drawings

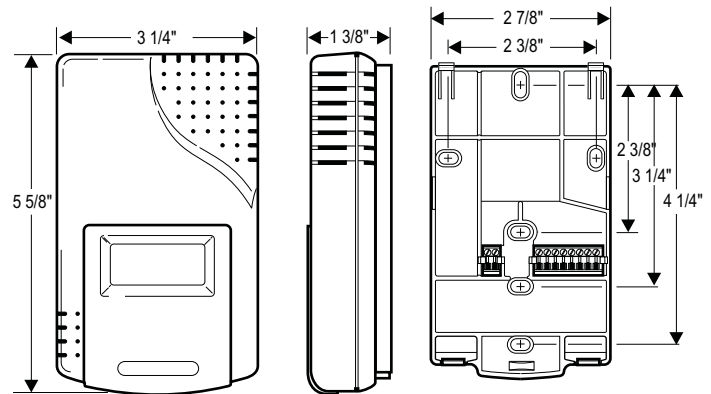

Comes with separate mounting bracket. Middle view shown with bracket installed.

Accessory Enclosures

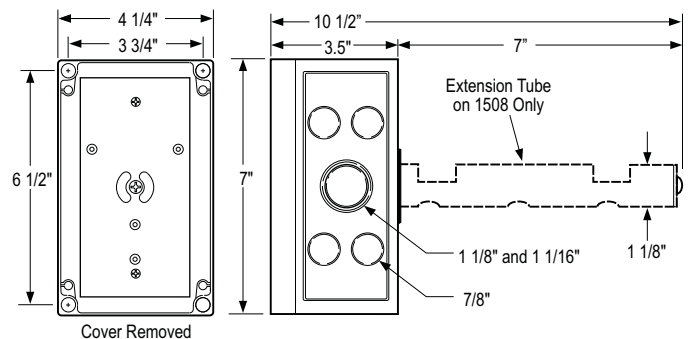

1505, 1508 and 1551 Enclosures. Enclosure housing is the same size for all 1500's with the exception of the 1508 which includes extension tube (as shown in illustration). The 1551 enclosure will allow the sensor to operate in low temperature environments to -20°F (-29°C)

4. Installing The Sensor

Basic Installation of the Mounting Plate & Sensor

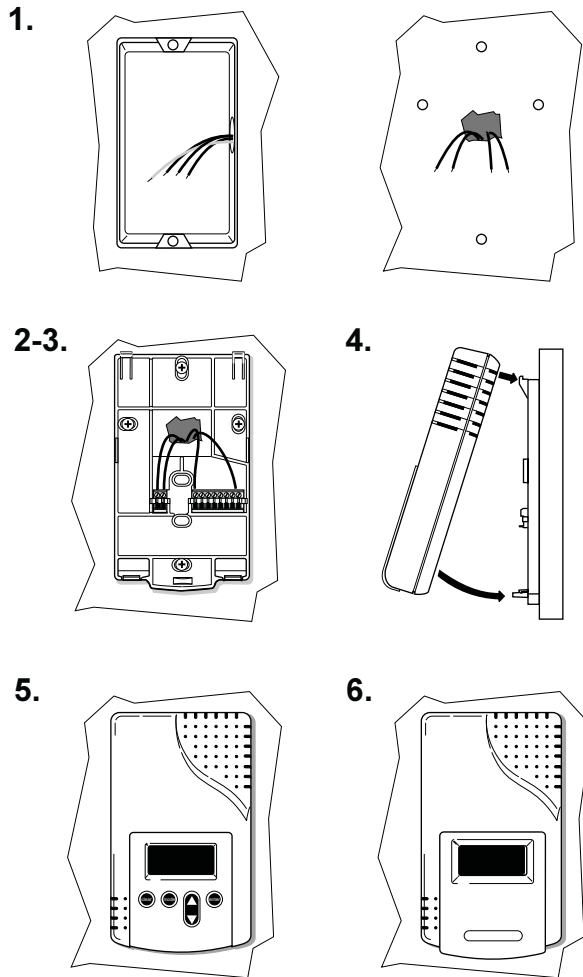

1. Prepare for installation by using the mounting holes configured for US or European junction boxes.
2. Use the mounting plate as a template to mark mounting holes.
3. Secure the Mounting Plate to the wall or junction box and make necessary wire connections.
4. Mount the Controller on the base by aligning the top clips and then securing to the bottom clips. A “snap” sound will indicate that the sensor is secure. The sensor will now have power. A 2 minute warm-up will take place. After 2 minutes, the sensor will stabilize and display the “**Normal Mode**” (current water vapor concentration).
5. Using the procedure noted in Section 7 adjust the sensor to provide the proper elevation correction for your location.
6. Finish installation by sliding the cover over the menu keys and secure with the supplied screw.

5. Accessory Enclosures

Model 1508 Duct Mount Enclosure (Aspiration Box)

The Vaporstat™ can be installed inside a model 1508 Duct Mount Enclosure to measure water vapor in the ductwork. The enclosure is mounted outside the ductwork for ease of maintenance and operation. Refer to the model 1508 Duct Mount Enclosure installation instructions for complete details.

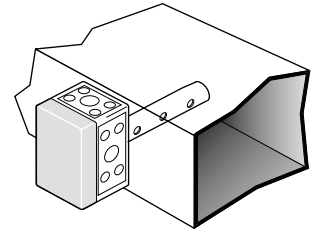

Model 1551 Outside Air Measurement Enclosure

The model 1551 Outside Air Measurement Enclosure allows the measurement of outside water vapor concentrations. This NEMA-3R weatherproof enclosure has two functions for a ventilation system: to control the system by directly comparing the outside and indoor water vapor levels; an internal temperature controller allows the sensor to make accurate outdoor measurements over an extended temperature range. Refer to the model 1551 Outside Air Measurement Enclosure installation instructions for complete details.

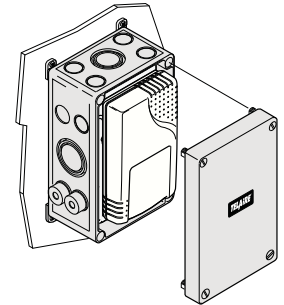

Model 1505 Harsh Environment Enclosure

The Model 1505 Harsh Environment Enclosure allows you to measure water vapor in extreme environments where the sensor might be subjected to condensation or water spray such as those found in greenhouses or breweries. The 1505 is NEMA-3R rated like the 1551, but it does not have the internal heat stabilizers. Refer to the Model 1505 Harsh Environment Enclosure installation instructions for complete details.

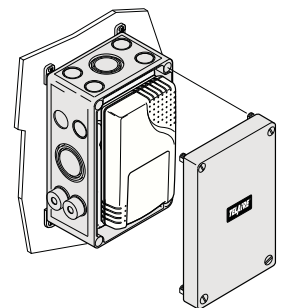

6. Typical Wiring Diagrams

The Vaporstat™ cannot be wired in a 2-wire configuration where the power supply also carries the current output of the sensor. Only the 3- and 4-wire configurations pictured above are possible.

Pin Designations for the Mounting Bracket

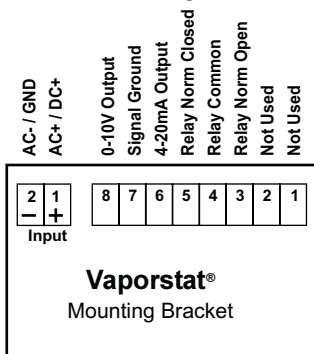

AC Power 3-Wire System

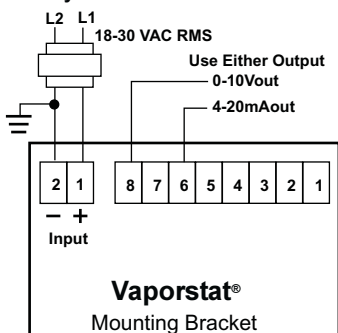

Isolated AC Power 4-Wire System

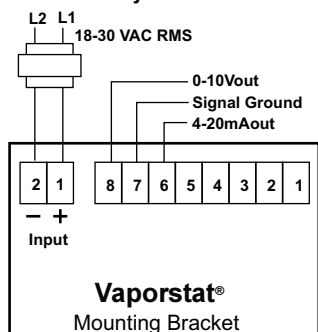

Using the Relay Contacts

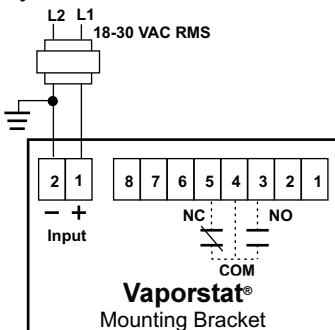

7. Vaporstat™ Operating Modes & Adjustments

7.1 Operating Modes

The Vaporstat™ has three operating modes:

Measurement Mode: The sensor operates in the measurement mode.

Adjustment Mode: Allows for adjustment of sensor operational characteristics including altitude correction, configuration of display/output, adjust measurement range, adjust analog output signal range, adjust relay set point and dead band.

Calibration Mode: This mode can be used to calibrate the sensor in the field.

7.2 Keypad Buttons

Clear: Exit Adjustment or Calibration mode and return to measurement mode.

Mode: When in the Adjustment Mode, the mode button will advance the Vaporstat™ to the next variable that can be adjusted.

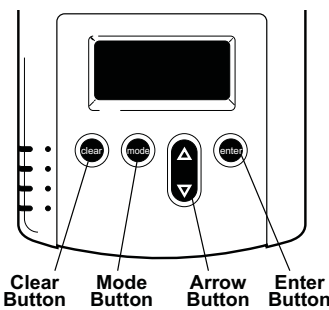

Arrows: Allows user to increase or decrease values or choose between selected variables in the sensor.

Enter: When an adjustment is made to the sensor, pressing the enter button will program the new setting or selection into the sensor.

Clear + Mode (3 sec): Enter Adjustment Mode

Clear + Enter (3 sec): Enter Calibration Mode

7.3 Adjusting the Sensor Using the Onboard Keypad

The sensor is shipped with the factory settings detailed below. These default settings can be adjusted using the keypad and procedures outlined in this section. When in Adjustment Mode, the selection of various adjustment parameters appears sequentially in the order detailed below. Pressing **clear** at any time will exit the Adjustment Mode.

Note: If an adjustment is made to any of the sensor parameters it will be retained by the Vaporstat™ even when the sensor is powered off. Adjustments to the output of the sensor will only apply to the unit of measure selected for the display mode. The non-selected display mode will continue to operate at its' factory setting. For example, if the output range of the dew point measurement is adjusted, the grains/lb settings will not be affected and remain at the initial factory settings.

Factory Settings

Default Measurement Unit	Dew Point	
Selected Measurement Unit	Dew Point	Grains/lb
Display	°F Dew Point	Grains/lb
Measurement Range	0-80°F Dew Point	0-140 Grains/lb
Analog Output	0-10V and 4-20 mA	0-10V and 4-20 mA
Relay Set Point	55°F Dew Point	65 Grains/lb
Relay Hysteresis (Dead Band)	2°F Dew Point	5 Grains/lb
Altitude	N/A	Sea Level (0 feet)

7.3.1 Adjustment Required For Installation

Select Display Units (°F dew point or grains/lb): Factory set for dew point. The units selected for display on the LCD will also correspond to the units used for the analog output and relay setting of the Vaporstat™

Set Elevation: Since the density of air and gases are affected by altitude, a correction must be made to the reading in grains/lb units, depending on the altitude. A local weather office can provide you with your area's average elevation (elevations for most major cities are also available at www.telaire.com). Use the navigation menu to go to Support > IAQ > Altitude Reference Chart. The sensor is factory set for sea level operation.

Calibration: It is also recommended that the user perform a single point zero or ambient calibration of the sensor to ensure maximum accuracy at start-up, for details please refer to Section 8, Calibration.

To Place In Adjustment Mode

1. Hold the **clear + mode** buttons for 5 seconds
2. Each adjustment mode will appear sequentially on the display. Pressing **mode** or **enter** will move to the next adjustment value. As described below, the sequence that adjustment values will appear in is as follows: Altitude, Display Units, Analog Output, and Relay.

To Adjust Altitude

1. Use the **arrow button** to adjust altitude up or down in 500-foot increments
2. When altitude is set press **enter** to store the correction in the sensor
3. Press **mode** to move to water vapor display or **clear** to exit Adjustment Mode

To Select Display/Output Units between Dew Point (DEW PT) or Grains/lb (Grains)

1. Press **mode** button to leave or skip the elevation selection
2. Use **arrows** to select **GRAINS** or **DEW PT**
3. Press **enter** to confirm selection
4. Press **mode** to move to SETTINGS or **clear** to exit Adjustment Mode

See section 8 for instructions on Calibration.

7.3.2 Output Adjustments

It is only necessary to make the adjustments described in this section if you would like to adjust the measurement range of the sensor, and/or the analog output range or adjust relay settings. If you do not wish to make these adjustments press **clear** after you have selected the display/output units.

To Adjust Output Ranges

1. Use the steps described in 7.3.1 to cycle through the startup adjustments on the sensor until you see the display SETTINGS.

2. Press the **mode** button to begin to adjust settings.

Adjust Measurement Value for Lower Output Limit (doesn't affect display)

1. The display will indicate **GRN FROM** or **DP FROM**
2. Use the **arrow** button to adjust the sensor output value you want to correspond to the low limit used for the analog output.
3. Press **enter** to confirm selection, an arrow should flash on the lower display (not necessary if no adjustment is made).
4. Press **mode** to move to the next selection

Adjust Measurement Value for Upper Output Limit (doesn't affect display)

1. The display will indicate **GRN TO** or **DP TO**
2. Use the **arrow** button to adjust the sensor output value you want to correspond to the upper limit used for the analog output (note it is possible to adjust the output to consider concentrations up to 300 grains or a 100°F dew point)
3. Press **enter** to confirm selection (not necessary if no adjustment is made).
4. Press **mode** to move to the next selection

Analog Output: The analog output of the sensor will correspond to the units selected for the LCD display. The sensor is factory set to provide linear 0-10 volt and 4-20ma outputs over the full measurement scale of the sensor. If necessary, the analog output range and the measurement range can be user-adjusted to meet any unique requirements as described below (e.g. a data logger, which may only accept a 0-5 volt input).

Select Analog Output Scaling Units

1. The top line of the display will read **OUTPUT:**
2. Use the **arrow** button to select if you want to scale the measurement range to **V** or **mA**. (Note: The scaling adjustment you select will be applied to both the voltage and mA output. For example, if you program a 0-5 volt output for a 0 to 80 F measurement range, the mA output will be 4-12mA for a 0 to 80 F measurement range.)
3. Once you have selected the preferred value for scaling (**V** or **mA**) press **mode**

Select Lower Limit For Analog Output

1. The top line of the display will read **V FROM** (or **mA FROM**)
2. Use the **arrow** button to select the lower analog output value you wish to use to correspond to the low limit measurement value set in Step 2 above
3. Press **enter** to confirm selection (not necessary if no adjustment is made)
4. Press **mode** to move to the next selection

Select Upper Limit For Analog Output

1. The top line of the display will read **V TO** (or **mA TO**)
2. Use the **arrow** button to select the upper analog output value you wish to use to correspond to the low limit measurement value set in Step 3 above
3. Press **enter** to confirm selection (not necessary if no adjustment is made)
4. Press **mode** to move to the next selection

Relay Set Point & Hysteresis: The normally open/closed relay contacts can be set to a specific set point and hysteresis (dead band). The set point is the point at which the relay is energized as concentrations rise. Hysteresis is the difference at which the relay de-energizes when concentrations drop below the set point. The sensor relay is factory-set to energize at 55°F dew point (65 grains/lb). The hysteresis is factory-set at 2°F dew point (5 grains/lb).

To Adjust Relay Activation Levels

1. The top line of the display will read **RELAY ON**
2. Use **arrows** to select relay on value desired (set point)
3. Press **enter** to confirm selection
4. Press **mode** button to go to the next selection
5. The top line of the display will read **HYSTER**
6. Use **arrows** to select relay hysteresis value desired (dead band)
7. Press **enter** to confirm selection
8. Press **mode** button to exit adjustment mode

8. Calibration

8.1 Overview

Periodic calibration of the Vaporstat™ is recommended to maintain optimum accuracy throughout the life of the sensor. Sensor calibration can be verified or reestablished at any time by using a reference device. Appropriate reference devices include a recently calibrated hand-held dew point sensor, or flowing a zero calibration gas through the sensor. Calibration using this technique will reestablish the sensor to its' original factory calibration curve.. Telaire offers the model 2076 calibration kit, which provides a zero calibration gas, certified to have less than 0.1 grains/lb of water vapor content, and is ideal for this purpose.

Infrared sensors are unique in that sensor drift occurs at the zero point of the sensor calibration and not the span concentration; therefore span calibration of the sensor is not required.

Please refer to the model 2076 calibration kit manual for additional information.

8.2 Calibration Description

The sensor provides two choices for calibration. Each method adjusts the zero setting of the sensor. Only one of these methods should be used for a calibration.

Single Point Calibration: This calibration mode allows the user to calibrate the sensor in ambient air to a known concentration as measured by a recently calibrated reference device (e.g. a hand held sensor which displays dew point or grains). This type of calibration will ensure that the greatest sensor accuracy is provided at or near this concentration used for calibration. This type of calibration is particularly recommended if high accuracy of the sensor is required over a narrow range of operation (e.g. clean rooms). To perform this calibration you must feel confident that the reference device you are using has been recently and properly calibrated. The calibration kit is not necessary to perform a Single Point Calibration.

Zero Point Calibration : This calibration mode allows the user to calibrate the sensor to a verified zero concentration of water vapor.

8.3 Calibration Procedure

Determine which calibration procedure you will use to calibrate the sensor - Single Point or Zero Point calibration. For best results, the sensor should be allowed to warm-up for at least ten minutes prior to calibration.

8.3.1 Single Point Calibration the reference measurement device should be warmed up and in normal measurement/operating mode. The Vaporstat™ should be in an environment where concentrations will remain very stable for a minimum of 10 minutes during calibration. Avoid breathing in the direction of the sensor. Exhaled air contains high levels of moisture and could disrupt the calibration process.

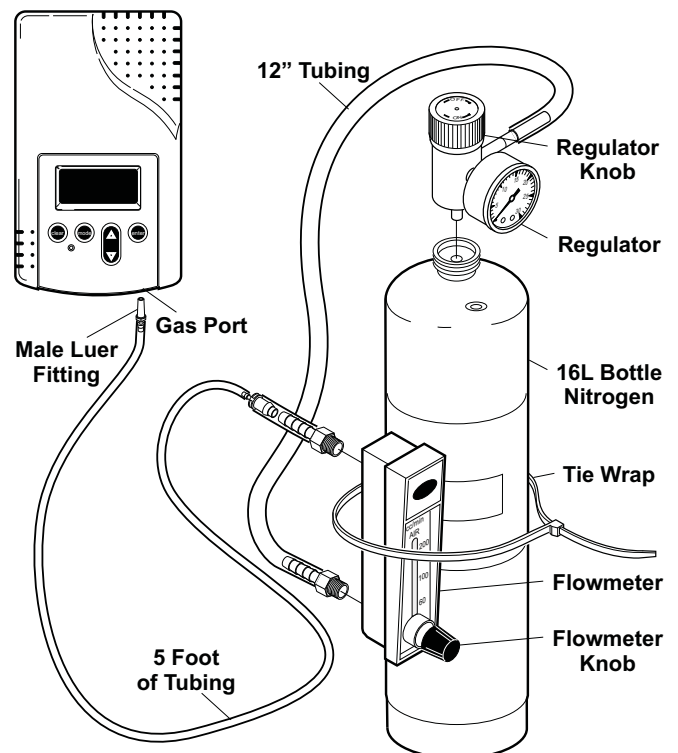

1. Press and hold the **clear + enter** buttons on the Vaporstat™ for 5 seconds. The word **CAL** will appear in the top line of the LCD Display.
2. Use the arrow buttons to change the display to read **SINGLE**. When **SINGLE** is displayed, a water vapor value will display in the lower screen.
3. Use the arrow button to adjust the sensor to reflect the concentration displayed on your reference device.
4. Press the **enter** button to calibrate the sensor to the value selected on the display based on ambient air conditions. Once the **enter** button is pressed the calibration process will take approximately 8 minutes, during which time the green LED below the display will flash. Once calibration is complete the sensor will revert to its normal display mode.

8.3.2 Zero Point Calibration all tubing should be connected between the gas bottle and the sensor inlet flow port. Gas should be flowing to the sensor at a rate of 80-100 cc/minute for a minimum of 5 minutes prior to initiating calibration.

1. Attach the short hose to the bottom port on the flow meter.
2. Attach the long hose to the top port on the flow meter.
3. To insure the meter is kept in the vertical position, secure the flow meter to the side of gas bottle using the supplied tie wrap
4. Remove the protective cap from the nitrogen bottle and attach the gas regulator
5. Attach the open end of the bottom hose (located on the flow meter) to the gas regulator. Slide the hose far enough on the gas port to ensure a secure, airtight connection
6. Insert the male Luer fitting (located on the longer hose) into the calibration port, located on the bottom of the Vaporstat™.
7. Verify all the components are installed correctly and initiate the calibration process by turning the knob on the regulator. Turn the knob until the indicator reaches 7 PSI
8. Turn the flow meter knob until the floater reaches 80-100 cc/min
9. Allow the gas to flow for at least 5 minutes before proceeding
10. Press and hold the **clear + enter** buttons on the keypad for 5 seconds. The word **CAL** will appear in the top line of the LCD Display
11. Use the arrow buttons to toggle to the **ZERO** calibration mode
12. When **ZERO** is displayed, press the **enter** button to initiate the calibration process
13. Once the **enter** button is pressed the calibration process will take approximately 8 minutes, during which time the green LED below the display will flash repeatedly. Once calibration is complete the sensor will revert to its normal display mode.
14. Once the display has returned to normal, turn the gas off and disconnect the tubing connection to complete the process

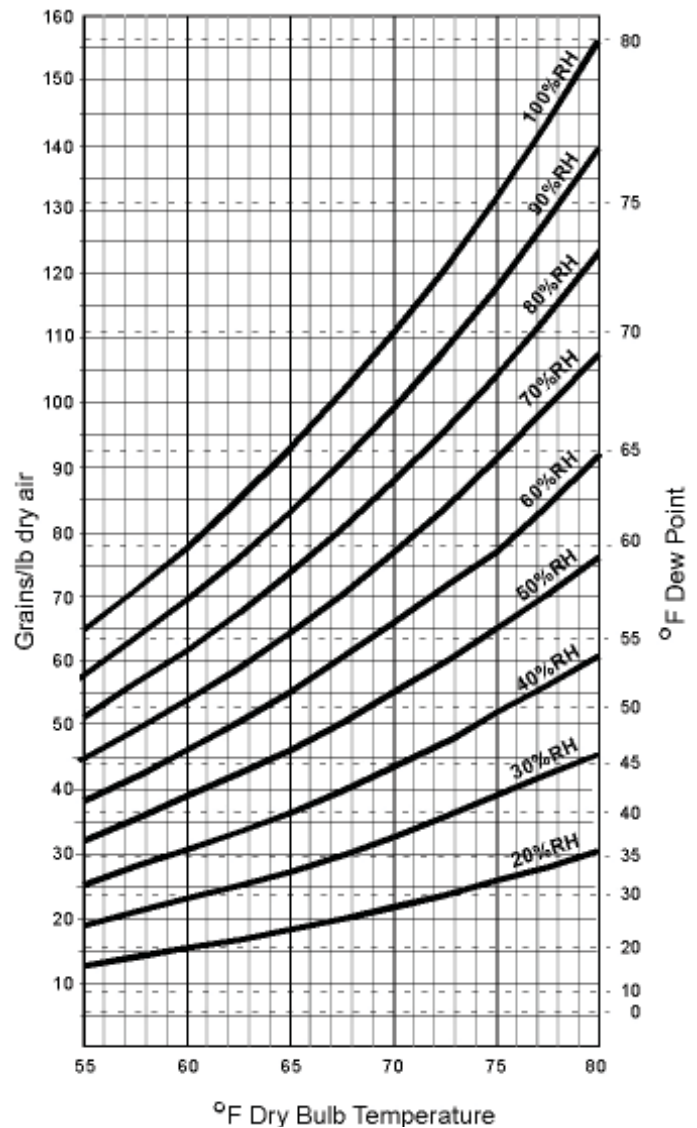

9.0 Conversion Factors

9.1 Dew Point & Relative Humidity (RH)

While the measure of relative humidity is highly dependent on the temperature of air, the measurement of dew point is not. We can use dew point to predict what the relative humidity of air will be at a particular temperature. For a designer or controls contractor this means that dew point can be used to predict and control water concentrations in air to ensure a target relative humidity is not exceeded for a design indoor temperature condition. The chart (on right) can be used to establish dew point set points for various common target relative humidity levels over a range of typical conditioned space temperatures.

10. Troubleshooting

Symptom

·LCD Display is blank after the 2-minute warm-up period.

Remedy

- Remove the sensor from the wiring plate and check the voltage on pins 1 and 2 of the 2-pin terminal block. The voltage should be: 18-30 VAC RMS or 18-42 VDC.
- Ensure that the sensor pins that connect to the 2-pin terminal block are not broken, bent, or damaged.
- If the LCD display is still blank after replacing the sensor on the mounting plate, call Telaire or your distributor/dealer for a return authorization number.

Symptom

·Green light is not illuminated after the two-minute warm-up period.

Remedy

- Remove the sensor from the wiring plate and check the voltage on pins 1 and 2 of the 2-pin terminal block. The voltage should be: 18-30 VAC RMS or 18-42 VDC.
- Ensure that the two pins on the sensor that connect to the 2-pin terminal block are not broken, bent, or damaged.
- If the green light is still not illuminated after replacing the sensor on the mounting plate, try verifying the sensor operation using the Vaporview™ software or checking the output signal on the building automation system.
- If there is not an output signal, call Telaire or your distributor/dealer for a return authorization number.

This product is covered by one or more of the following patents:

5,650,624
 5,721,430
 5,444,249
 5,747,808
 5,834,777
 5,163,332
 5,340,986
 5,502,308
 6,344,798
 6,023,069
 5,370,114
 5,601,079
 5,691,704
 5,767,776
 5,966,077
 6,107,925
 5,798,700
 5,945,924
 5,592,147
 6,255,653
 6,250,133
 6,285,290

Symptom

·Suspect the sensor is out of calibration.

Remedy

- Perform a zero calibration on the sensor using the procedure described in step 8.

Symptom

·Relay does not actuate at the proper set point.

Remedy

- Using the LCD menu, verify that the relay set point is correct.
- If the relay does not actuate at the proper set point, call Telaire or your distributor/dealer for a return authorization number.

Warranty

Telaire seeks to present reliable information concerning the composition, properties and use of its products, however; (1) All advice concerning selection and use of any product is provided at no charge and with no warranty. (2) No warranty is made hereby. Products described herein are warranted to conform to Telaire specifications only at the time of sale. All sales are subject to Telaire standard terms and conditions, which are reproduced on the reverse side of each invoice. All warranties of merchantability and fitness of purpose are disclaimed and remedy for any breach of warranty is limited to replacement of the defective product. (3) Telaire assumes no responsibility for any patent liability arising from the use of any product in a process, manner or formula not designed by Telaire.



DMW19 Wall Mount Dewpoint Transmitter for Indoor Applications



Vaisala HUMICAP® Dewpoint Transmitter DMW19 is a compact wall mount dewpoint transmitter.

The wall mount Vaisala HUMICAP® Dewpoint Transmitter DMW19 is designed for use in air conditioning and other indoor wall mount applications where accurate and stable dewpoint measurement is required. DMW19 is an ideal choice for demanding building automation applications where dewpoint is the preferred parameter for humidity measurement.

Proven Vaisala HUMICAP® Sensor Technology

The operation of DMW19 is based on Vaisala HUMICAP® Sensor. The dewpoint is calculated from relative humidity and temperature. The patented Vaisala HUMICAP® Sensor is insensitive to dust, particulate dirt and most chemicals. This results in high accuracy, excellent long-term stability and negligible hysteresis.

Easy to install

DMW19 is compact and lightweight. In addition, DMW19 is easy to install and it is suitable for different junction boxes.

Fast, on-site field check

The accuracy of the transmitter is simple to check on-site using the Vaisala HUMICAP® Hand-Held Humidity and Temperature Meter HM70.

Customized calibration and maintenance contracts for the DMW19 are available on request.

Features/Benefits

- Designed for demanding building automation applications and other wall mount indoor applications where dewpoint measurement is needed
- Dewpoint measurement range $-20...+55\text{ }^{\circ}\text{C T}_d$ ($-4...+131\text{ }^{\circ}\text{F T}_d$)
- Accuracy $\pm 2\text{ }^{\circ}\text{C T}_d$
- Vaisala HUMICAP® Sensor for excellent accuracy and long-term stability, negligible hysteresis and resistance to dust and most chemicals.
- Electronic, on site, one-point field check with Vaisala HUMICAP® Hand-Held Humidity and Temperature Meter HM70



DMW19 is suitable for demanding building automation and other wall mount indoor dewpoint measurements.

The Vaisala HUMICAP® Hand-Held Humidity and Temperature Meter HM70 is an easy and fast way to confirm the performance of DMW19 on site.



Technical Data

Dewpoint temperature

Measurement range	-20...+55 °C (-4...+131 °F)
Accuracy	±2 °C (±3.6 °F) (See the graph below)

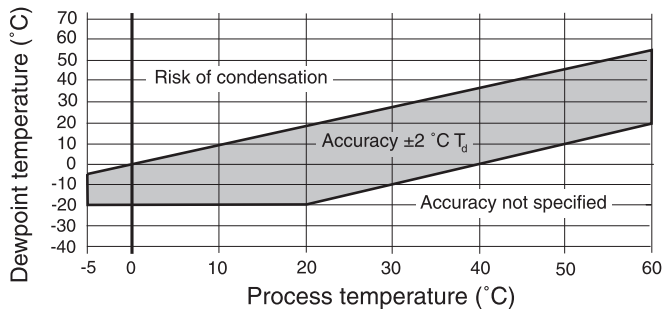

Response time	15 s
Humidity sensor	Vaisala HUMICAP® 180
Temperature sensor	Pt 100 IEC 751 1/3 class B

Operating environment

Operating temperature	-5...+60 °C (+23...+140 °F)
Storage temperature	-40...+80 °C (-40...+176 °F)
Relative humidity	0...95 %RH operating and storage

Outputs

Analog output (scalable)	4...20 mA 0...1 V 0...5 V
Resolution for current output	0.002 mA
Resolution for voltage output	0.3 mV
Typical temperature dependence	0.005% of span/°C

General

Operation voltage with voltage output	12...35 VDC 11...28 VAC
Operation voltage with current output	20...35 VDC / 19...28 VAC with RL500 ohm 17...35 VDC / 16...28 VAC with RL50 ohm
Supply current	10 mA + load current
Load for voltage output	min. 10 kohm
Load for current output	max. 500 ohm
Connections	screw terminals 0.5...1.5 mm ²

Housing	ABS plastics
Housing classification	IP33
Weight	110 g

Options and Accessories

For field check	HM70 hand-held humidity and temperature meter
Connection cable for HM70	211917ZZ

Electromagnetic compatibility

Complies with EMC standard EN61326-1:1997 + Am1:1998 + Am2:2001; Generic Environment.

Wiring

R_L 50 Ohm: 17-35 VDC
16-28 VDC

R_L 500 Ohm: 20-35 VDC
19-28 VAC

R_{L min} 10 kOhm: 12-35 VDC
11-28 VAC

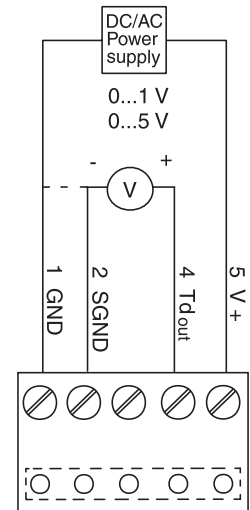
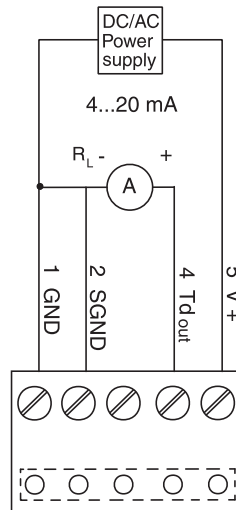

Dimensions

Dimensions in mm.

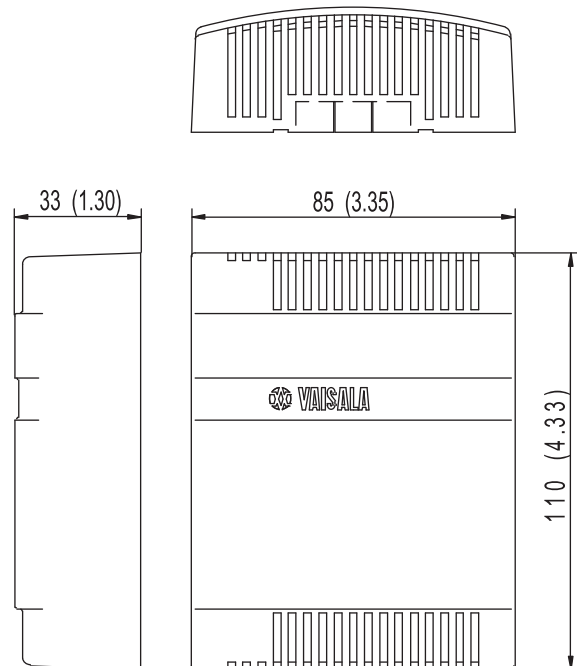

HMT100 Series Humidity and Temperature Transmitter for Demanding HVAC Applications



HMT100 remote probe and wall mount models.

Features/Benefits

- Full 0 ... 100 %RH measurement
- Two-wire loop-powered or three-wire voltage output configurations
- Fixed and remote probe models
- Display available
- Relative humidity, dewpoint, temperature outputs
- Vaisala HUMICAP® sensor
- Interchangeable probe module for minimal maintenance downtime
- Different output scalings
- Compatible with hand-helds HM70 and HMI41 for calibration
- IP65 (NEMA 4) housing
- NIST traceable (certificate included)

The Vaisala HUMICAP® Humidity and Temperature Transmitter Series HMT100 are designed for humidity and temperature monitoring in demanding environments.

Typical applications include stability rooms, HVAC, livestock farms, greenhouses, indoor swimming pools, and outdoor applications.

Performance

HMT100 incorporates Vaisala HUMICAP® technology that measures relative humidity accurately and reliably. Vaisala HUMICAP® is also resistant to dust and most chemicals.

Available options

The HMT100 is available as a wall mount or remote probe model with an optional display. For high temperature applications or where space is limited, the remote probe is ideal.

HMT100 can show relative humidity only, dewpoint only, or relative humidity and temperature, or dewpoint and temperature readings.

The probes are interchangeable without having to calibrate or adjust the transmitter.

HMT100 can also be installed outdoors using an installation kit, or directly into an air conditioning channel using a duct installation kit.

Annual calibration

Calibration is recommended typically at an interval of one year using either the Vaisala HUMICAP® Hand-held Humidity and Temperature Meter HM70 or the Vaisala HUMICAP® Humidity Indicator HMI41.

The accuracy of the instrument can also be checked using the Vaisala Humidity Calibrator HMK15, which is based on saturated salt solutions.

Technical data

Performance

RELATIVE HUMIDITY	
Measurement range	0 ... 100 %RH
Accuracy against factory standards including non-linearity, hysteresis, and repeatability	
at +15 ... +25 °C (+59 ... +77 °F)	±1.7 %RH (0 ... 90 %RH) ±2.5 %RH (90 ... 100 %RH)
at ±0 °C ... +40 °C (+32 ... +104 °F)	±(1.7 +0.015 x reading) %RH
at -40 ... +20 °C, +40 ... +80 °C (-40 ... +32 °F, +104 ... +176 °F)	±(2.0+0.025 x reading) %RH
Factory calibration uncertainty	
at +20 °C (+68 °F)	±1.0 %RH (0 ... 15 %RH) ±1.5 %RH (>15 ... 78 %RH)
Response time (90 %) at 20 °C in still air	
	8 s with plastic grid 20 s with membrane filter 40 s with sintered filter
Humidity sensor	Vaisala HUMICAP® 180
TEMPERATURE	
Measurement range	-40 ... +80 °C (-40 ... 176 °F)
Accuracy at +20 °C (+68 °F)	±0.2 °C (±0.36 °F)

ACCURACY OVER TEMPERATURE RANGE

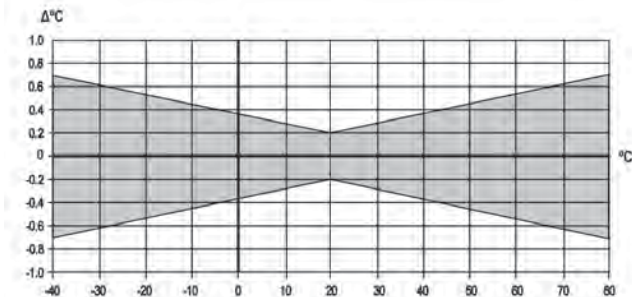

Temperature sensor	Pt1000 IEC 751 1/3 class B
DEWPOINT TEMPERATURE (CALCULATED)	
Measuring range	-20 ... +80 °C (-4 ... +176 °F)

Operating Environment

Operating temperature range	
transmitter body, no display	-40 ... +60 °C (-40 ... +140 °F)
transmitter body, with display	-30 ... +60 °C (-22 ... +140 °F)
probe (remote probe only)	-40 ... +80 °C (-40 ... +176 °F)
Storage temperature range	-40 ... +60 °C (-40 ... +140 °F)
Electromagnetic compatibility	EN61326-1, Industrial Environment

Inputs and outputs

Two-wire output signal	4 ... 20 mA
External loop load	10 ... 35 VDC ($R_L = 0$ ohms) 20 ... 35 VDC ($R_L = 500$ ohms)
Voltage output signals	0 ... 1 V, 0 ... 5 V, 0 ... 10 V (0 ... X.V see order form)
Supply voltage	10 ... 35 VDC/24 VAC
Current consumption, 35 VDC/24 VAC	max. 12 mA
External load	R_L min. 10 kΩ

Mechanics

Material	
Housing	ABS/PC plastic
Probe	chrome coated aluminum
Mounting plate GM45160	ABS plastic
Housing classification	IP65 (NEMA 4)
Sensor protection	
Plastic grid	DRW010522
Plastic grid with membrane filter	DRW010525
Sintered stainless steel filter	HM46670SP
Connections	screw terminals 0.5 ... 1.5 mm ²
Probe cable lengths	3 m, 5 m, 10 m
Calibration	with HM70, HMI41, or with internal 11 %RH & 75 %RH buttons
Display option	
	One line fixed variable or changing variables when two variables are ordered

Options and accessories

Spare probe	HMP100
Spare extension cable (10 m)	DRW220095
Radiation shield	DTR502B
Rain shield with installation kit	215109
Installation plate	DRW010699
Duct installation kit	215619
Connection cable for HMI41	2591722
Connection cable for HM70	211339

Ref. 210472EN-B ©Vaisala 2009

This material is subject to copyright protection, with all copyrights retained by Vaisala and its individual partners. All rights reserved. Any logos and/or product names are trademarks of Vaisala or its individual partners. The reproduction, transfer, distribution or storage of information contained in this brochure in any form without the prior written consent of Vaisala is strictly prohibited. All specifications — technical included — are subject to change without notice.

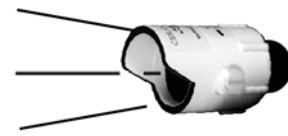

PD

Linear Photodiode Sensors for
PLC-Multipoint Controllers

DESCRIPTION

The **PLC-MULTIPOINT PD** is a Class 2, low voltage light sensor designed to provide input to **PLC-MULTIPOINT** controllers. The **PD** sensor may also serve as input into analog scaling boards used in energy management systems. **PD** sensor models are available in a wide variety of light sensing ranges and housing styles.

The **PD** allows the **PLC-MULTIPOINT** controllers to switch banks of lights on and off, or provide continuous signals to electronic dimming ballasts for fluorescent fixtures.

ADJUSTABILITY

The sensor sensitivity is adjustable. **PD** sensor adjustments are made remotely at the controller board, not at the sensor head. The sensor measures dark at 0 VDC and maximum light level at 9 VDC and provides an output selection range at 9 VDC of 750, 2,500, 4,000 or up to 10,000 FC.

CONSTRUCTION

To achieve the highest degree of performance and reliability, all components are of computer grade quality and are assembled on a fiberglass epoxy circuit board. The electronic circuit of all exterior sensor models is encased in a clear, glass-like epoxy and sealed with an electronic grade, non-corrosive urethane resin. Skylight and outdoor models are housed in Cyclac T (TM) for UV stabilization.

SENSORS FOR ALL APPLICATIONS

All indoor sensors have a flat Fresnel lens that looks downward in a 60 degree cone of reference to measure actual light on the work surface. The Fresnel lens is used to reduce the influence of stray light striking the sensor from nearby windows or incidental side lighting.

The Outdoor sensor is enclosed in a weatherproof housing with a visor for shading and lens protection.

The Atrium and Skylight sensors both use diffusing dome lenses to provide a 180 degree angle of photodiode response.



SENSOR

FEATURES

- Adjustable maximum output voltage for high resolution in 10-7,500 FC range.
- Remote sensor calibration.
- Indoor sensor with 60 degree clear Fresnel Lens, Adhesive mounting to ceiling, facing down. Sensor range 0/5-750 FC.
- Outdoor sensor with flat clear lens. Two sensors ranges: 0/5-750FC and 0/500-2500FC. 1/2" IPT connection for horizontal mounting. Weather proof housing.
- Atrium sensor with opaque dome lens filters 33% of light level in upper atrium. Sensor range 2/200-4,000 FC. 1/2" IPT connection for horizontal mounting.
- Skylight sensor with dark dome lens filters 90% of light level in skylight. Sensor range: 10/1,000-10,000 FC in skylight. 1/2" IPT connection to for upward vertical mounting.
- Interface with LC3X PLC-MULTIPOINT controller.
- Fully patented technology.
- 2 year warranty.

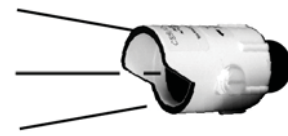

PD TECHNICAL DATA

Accuracy:	+/-1% at 70 F (21 C) Derated to +/-5% at 120 F or at 0 F (-18 C to 49 C)
Operating Temp:	13 F to +140 F. (-11 C to 60 C)
Sensor Type:	Blue-enhanced Photo Diode
Sensor Ranges:	<u>Minimum</u> <u>Adjustable Max</u>
PD1 - Indoor	0 Fc 2-750 Fc
PD5 - Outdoor	0 Fc 2-750 Fc
PD5D - Outdoor	5 Fc 500-2,500 Fc
PD9 - Atrium	2 Fc 200-4,000 Fc
PD9D - Skylight	10 Fc 1,000-10,000 Fc
PD9DT - Tunnel	10 Fc 1,000-10,000 Fc
Input Voltage:	12VDC from controller
Output Voltage:	0 at darkness to 9 VDC at full output
PC Input Controls:	LC3X-3X/PD, LC6, LC7B4, LC7B6, PD-SIM
Wiring:	4 conductor 18 ga. stranded
Cabl	e.
Red:	Signal
Black:	+12VDC
Yellow:	Remote gain adjust
Gree	n: DC common

PD SENSOR SELECTOR

SENSOR LENS FILTE R MOUN TING ORIE NT Heigh t Dia.

PD1 Fresnel	Clear	Ceiling	Down	2.00"	1.23"
PD5 Flat	Clear	1/2" IPT	Horiz.	1.85"	1.28"
PD5D Flat	Dark	1/2" IPT	Horiz.	1.85"	1.28"
PD9 Dome	Opaque	1/2" IPT	Horiz.	2.25"	1.28"
PD9D Dome Dark		1/2" IPT	Up	2.25"	1.28"
PD9DT Dome	Dark	1/2" IPT	Horiz.	2.25"	1.28"

SPECIFICATION

PHOTODIODE SENSOR

The photoelectric device shall be a Class 2, low voltage, ambient light sensor designed to interface directly with the analog input of the controller. The sensor shall supply an analog signal to the controller system proportional to the light measured. The sensor shall be capable of a fully adjustable response in the range between 0 and 10,000 footcandles with a +/-1% accuracy at 70 degrees F (21 deg. C).

The sensitivity adjustment shall be remote at the controller. The sensor housing shall be constructed from GE Cyclocac (R) ABS, shall be flame retardant and meet UL 94 HB standards.

INDOOR

Indoor sensors shall have a Fresnel lens, with a 60 degree cone of response. Indoor sensors shall only require a penetration hole in the ceiling of 3/8" dia. and the sensor shall mount to the ceiling using adhesive tape. The indoor sensor range shall be between 0 and 750 FC. The indoor sensor shall be **PLC-MULTIPOINT PD1**.

OUTDOOR

Outdoor models shall have a hood over the aperture to shield the sensor from direct sunlight. The outdoor sensor circuitry shall be completely encased in an optically clear epoxy resin. Outdoor sensors shall mount to a standard threaded 1/2" conduit or fit a 1/2" knockout. The Outdoor sensor shall have two ranges: between 0 and 750 FC or 5 and 2500 FC. The outdoor sensor shall be **PLC-MULTIPOINT PD5 or PD5D**.

ATRIUM or SKYLIGHT

The Atrium or Skylight sensors shall have a translucent dome with a 180 degree field of view. Atrium or Skylight sensors shall mount to standard threaded 1/2" conduit or fit a 1/2" knockout. Atrium sensor range shall be from 2 to 4,000 FC. Skylight sensor range shall be between 10 and 10,000 FC. The Atrium or Skylight sensors shall be **PLC-MULTIPOINT PD9 or PD9D**.

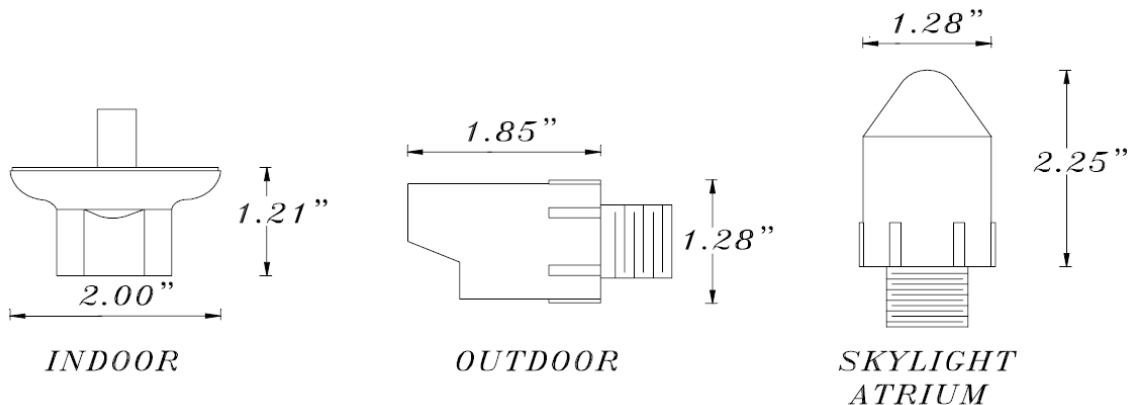

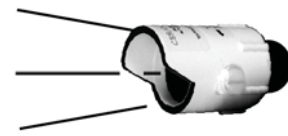

PHOTO DIODE SENSOR APPLICATION NOTE

SENSOR CALIBRATION & SETPOINT DETERMINATION

Photodiode (PD) sensors are sensitive to the amount of light sensed in blue bandwidth. PD sensors are different from Photoconductive sensors in two ways. PD sensors provide a linear response over the range of the sensor and have an adjustable footcandle sensitivity. Thus the same sensor can be calibrated for a wide variety of response ranges. The following figure shows a range response for a Photodiode sensor.

Calibration of the PD sensor is accomplished by a potentiometer in PLC-MULTIPOINT LC series controller boards such as the LC3X with 3X/PD adaptor board, LC6, LC7B4 and LC7B6. The adjustment of this potentiometer changes the sensitivity or **Footcandles per Volt (FC/V)** that the sensor uses in its output signal. PD sensors have a 0 to 8VDC output signal range. The sensitivity adjustment is used to optimized the light level range of the sensor. An optimized sensor range is important for control because it provides the best resolution of the sensor to precisely allow the controller to switch at the desired lighting levels. The PD sensor ranges are characterized as follows:

MODEL	APPLICATION	MINIMUM	MAXIMUM
PD1	Indoor	0 FC	2-750 FC
PD5	Outdoor	0 FC	2-750 FC
PD5D	Outdoor	5 FC	5-2500 FC
PD9	Atrium	2 FC	200-4,000 FC
PD9D	Skylight	10 FC	1,000-10,000 FC
PD9DT	Tunnel	10 FC	1,000-10,000 FC

For the PD9 Atrium sensor highlighted above the minimum footcandle detection level is fixed at 2FC. The maximum footcandle detection level can be calibrated from 200 to 4,000 FC. A good guideline to use in range selection is that the maximum sensor range should be approximately **30% higher** than the highest setpoint. For example, if the highest switching setpoint is 1,000 Footcandles, then maximum calibration range of the sensor should be 1300 FC.

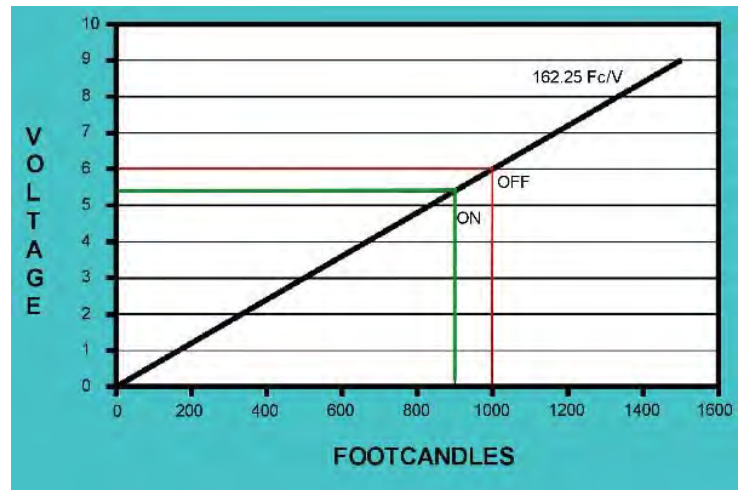

Photodiode sensors require that the FC/V ratio be calculated:

$$\text{Footcandle per Volt} = \frac{(\text{Maximum-Minimum Footcandle})}{(8-0)\text{VDC}}$$

In the example above for a PD9 sensor, the sensitivity is calculated as follows:

$$(1300-2)\text{FC} / (8-0)\text{V} = 162.25 \text{ FC/V}$$

This ratio is used to select setpoint voltages.

To switch lights OFF at 1000 FC, the corresponding voltage is:

$$(1000\text{FC} / 162.25\text{FC/V}) = 6.16\text{V}$$

To switch lights ON at 900 FC, the corresponding voltage is

$$(900\text{FC} / 162.25\text{FC/V}) = 5.55\text{V}$$

By setting a PLC-MULTIPOINT PD-SIM to these voltages, and providing it as an input into a controller, the controller's setpoint potentiometers are adjusted to switch at that lighting level.

PD SENSORS INSTALLATION AND
MAINTENANCE MANUAL (IMM)

p/n 51440T rev 11/04/05

PLC  MULTIPPOINT, INC.

PD SENSORS INSTALLATION AND MAINTENANCE MANUAL (IMM) p/n 51440T

GENERAL

1. Please read these instructions carefully to prevent any possible injury or equipment damage.
2. Installer must be a qualified and experienced service technician.
3. Verify the product ratings to confirm that this product will satisfy your requirements and application.

INTRODUCTION

PD sensors are available in 6 different ranges depending on the application with one Indoor, two Outdoor, one Atrium one Skylight and one Tunnel versions. Each sensor will function with a variety of PLC-Multipoint controller products. Refer to **figures 1A - 1F** for mounting locations and recommendations.

INSTALLATION

1. Indoor Sensor (Ceiling)

Mount the Indoor sensor in a 3/8" hole in the false ceiling tile using the adhesive backing. For most general applications the sensor should be mounted between 6-8 feet of the window area, central to the area illuminated by the electrical lighting that will be controlled. In all cases the sensor must be mounted so that it looks at reflected light only and not at any direct light. (See **Fig. 1A**).

2. Indoor Sensor (Reflecting Wall)

Mount the Indoor sensor at reflecting wall. When sconces are in place in the light well, make sure not to mount sensor in direct level as the sconces. Place sensor 18" from the bottom corner of the ceiling. Remember, the Fresnel lens will see light with a field of view that is 1.15 times the distance to the wall. No direct lighting should be within the field of view. (See **Fig. 1C**).

3. Outdoor Sensor

Mount the Outdoor sensor in a standard threaded 1/2" conduit or 1/2" knockout. Locate the sensor on the roof or somewhere that is exposed to full daylight and is not shadowed or directly exposed to any nighttime illumination. Sensor must be mounted horizontally, facing North, with the hooded portion on top. (See Fig. 1E)

4. Atrium Sensor

Mount the Atrium Sensor in a standard threaded 1/2" conduit or 1/2" knockout. Locate the sensor at the opposite side of the window mounting the sensor against the wall or ideally in the middle of the atrium glass facing towards the Atrium glass. (See Fig. 1B).

5. Skylight Sensor

Mount the Skylight sensor in a standard threaded 1/2" conduit or 1/2" knock-out. Locate the assembly near the center of the skylight well (at least 12" from the side) that is exposed to full daylight and is not shadowed. For the best results, use unistrut with a 1/4" angle support, making sure the top of the light sensor is level with top of skylight curb. Sensor must be mounted vertically with the domed portion facing up. (See Fig. 1D).

CONNECTIONS

Connect the PD sensor to the controller board. Use at least 18 AWG four conductor shielded cable with a drain wire. For boards that use phone jack plugs, (such as the LC7B4 and LC7B6) connect sensor with 4 conductor phone cable. Some controller boards can accept either phone or regular 4 conductor cable. In these cases, the 4 conductor cable is recommended. Do not run sensor wires near any high voltage area or near anyplace with high electrical noise. Clip back the drain wire at the sensor and connect the other end near the controller to a good ground. Refer to the installation and maintenance manual (IMM) for each controller board for specific connection terminals. Observe the following PD sensor polarity:

Black: 12VDC input

Red: Signal

Green: DC common

Yellow: Remote gain adjust

Butt splice connections are recommended, but wire nuts are acceptable.

CALIBRATION

The PD sensors themselves can not be calibrated. All calibration and adjustments are done on the controller boards. Refer to the IMM for each controller board for a detailed procedure.

MAINTENANCE

Every 2 months wipe the lens clean with a non-scratching clean cloth and ensure that no foreign debris remains. Check the housing for damage such as cracks, burns or other deformations. Check that no moisture has penetrated the sensor, as this will likely render it inoperable.

FIGURES: 1A-1E PD SENSOR LOCATION

OPERATION

The PD sensor is functioning when the controller board is activated. There are no switches or other user controls on the sensor.

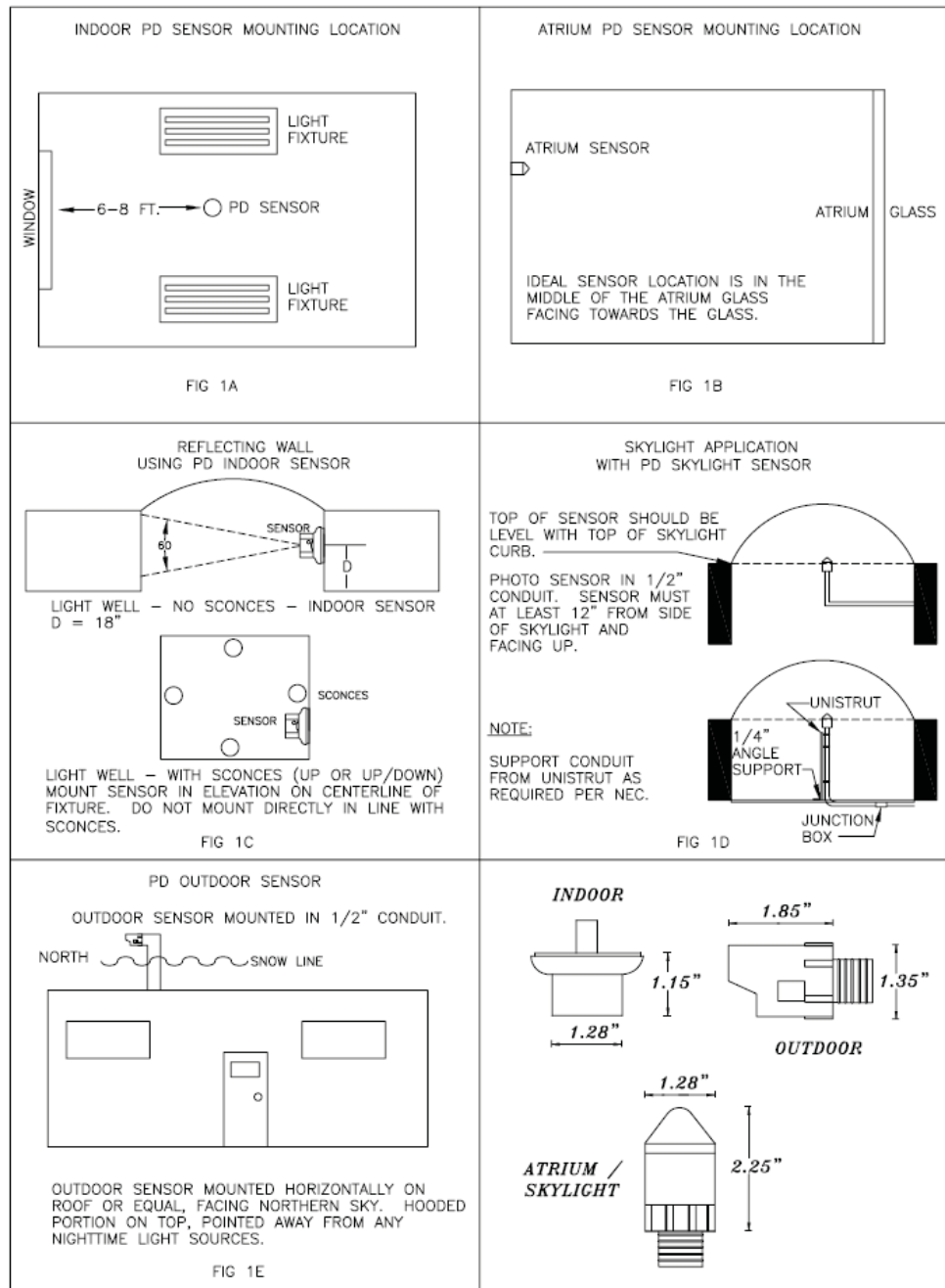

Accessory Enclosures

For the Ventostat 8000 Series



Telaire® offers three accessory enclosures that are designed enhance the 8000 Series Ventostat® CO2 Sensor/Controller in specialized applications.

Model 1508 Aspiration Box:
Designed for in-duct sampling of CO2 in flow rates greater than 400 fpm.

Model 1505 Splash Resistant Enclosure:
Designed to protect the 8000 series in damp or wet environments as might occur in agricultural, industrial or food processing environments.

Model 1551 Outdoor Air Enclosure:

A weatherproof enclosure designed to allow the 8000 series sensor to operate in an outdoor environment and/or where ambient temperatures are below freezing. Ideal for monitoring outside air or CO2 as a surrogate for combustion fumes in parking garages, tunnels and loading docks.

Enclosures are sold separately from CO2 sensor/controllers

1508 Aspiration Box



The Model 1508 is designed for in-duct sampling of CO₂ concentrations at flow rates greater than 400 fpm. Clear cover allows for observation of the sensor. Will accommodate any wall mount model of Telaire® Ventostat® 8000 series. Enclosure is screwed to the duct with probe inserted into airstream. Air sampling probe is 1" in diameter and 8" long. Enclosure (ABS plastic) has knockouts for conduit connection. Note: Wiring penetrations must be sealed prior to use. CO₂ sensor not included.

1505 Splash Resistant Enclosure:



The Model 1505 is designed to protect the 8000 series in damp or wet environments as might occur in agricultural, industrial or food processing environments. This enclosure (ABS plastic) is designed to protect the sensor from dripping or sprayed water. Any wall mount model of the Telaire® 8000 series sensor can be installed inside the enclosure. The transparent cover allows for viewing of the sensor/display. Four diffusion ports allow for entry of CO₂. Knockouts are provided for conduit connection. Response time of the sensor is slowed to approximately 30 minutes to measure a 90% step change in concentrations. Enclosure is designed to screw directly to a wall. CO₂ sensor not included.

1551 Outside Air Enclosure:



The Model 1551 is a rugged weatherproof enclosure (ABS plastic), designed to allow the 8000 series sensor to operate in an outdoor environment and/or where ambient temperatures are below freezing. The 1551 is ideal for monitoring outside air or CO₂ as a surrogate for combustion fumes in parking garages, tunnels and loading docks. This enclosure features a temperature control circuit and internal heaters to maintain the sensor within it's normal operating temperature range, even if temperatures outside the enclosure are as low as -20 F (-29°C). Four diffusion ports allow for entry of CO₂. Response time of the sensor is slowed to approximately 30 minutes to measure a 90% step change in concentrations. Enclosure is designed to screw directly to a wall. CO₂ sensor not included.

Power Consumption: 24V, 1.5 Amp (max) - including Ventostat® 8000 series

Cross Reference: The Model 1551 Outside Air Enclosure combined with a Telaire® Ventostat® 8000 series meets or exceeds the performance requirements of the Telaire® Model 2051 Outside Air Enclosure.

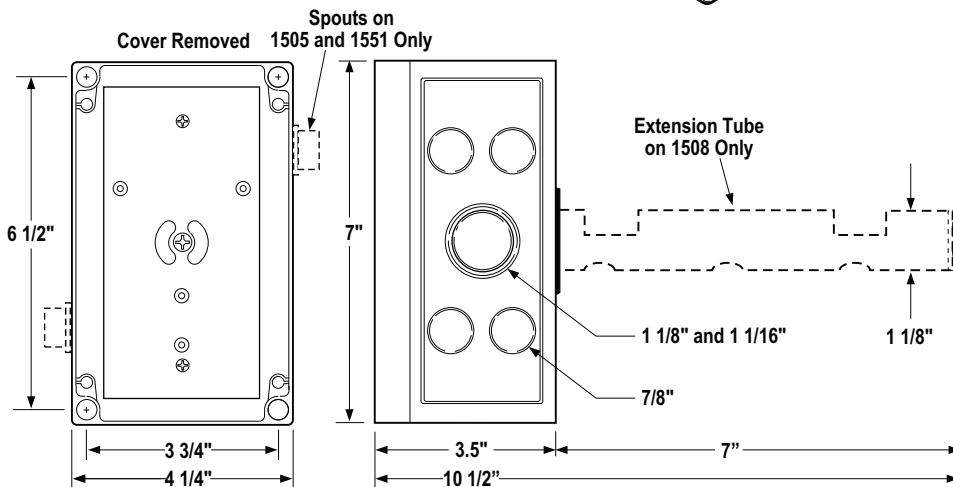
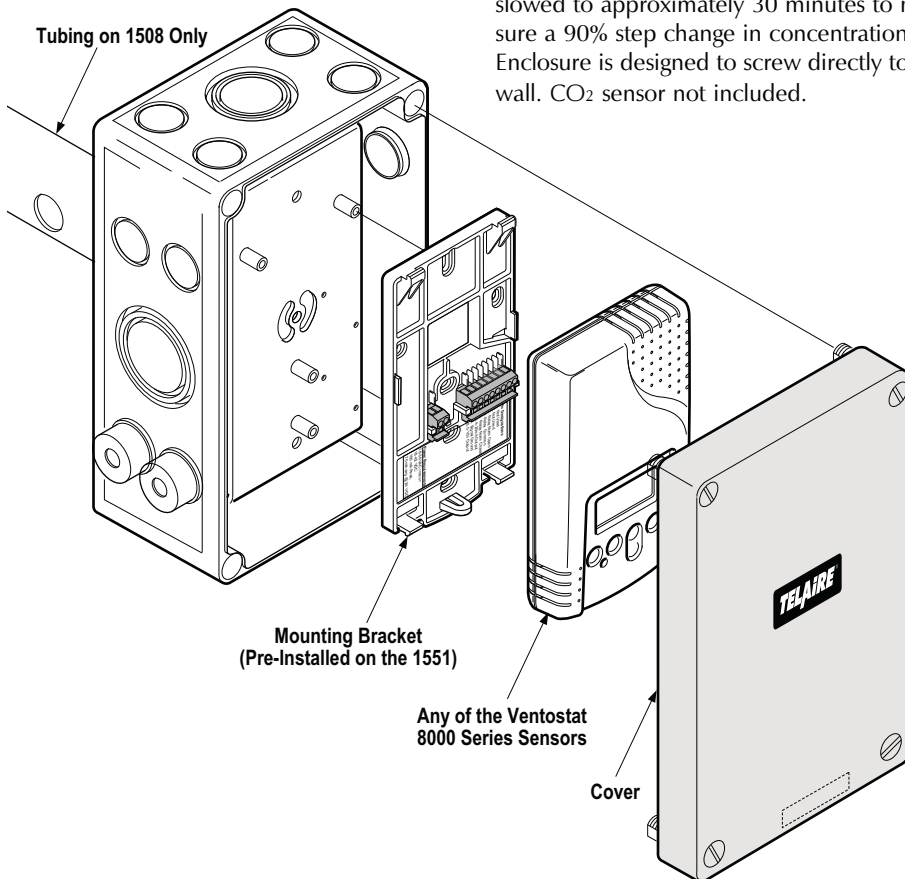

Continental Control Systems

WATTNODE® PLUS

AC Power Measurement for LONWORKS®

THE WATTNODE PLUS for LonWorks is a networked, multi-function digital power meter and monitor. The WATTNODE PLUS offers true RMS power metering, PLUS demand, PLUS individual phase voltage and current, PLUS individual and average power factor, PLUS reactive power and energy metering, PLUS frequency. Typical applications include energy monitoring, sub-metering, demand management, power factor control and phase-load monitoring.

NETWORKING the WATTNODE PLUS for LonWorks is easy. A simple twisted-pair connection links all devices together into a dependable LonWorks network. In addition, a LonWorks gateway provides network access via the Internet. Measurements are transmitted over the network as Standard Network Variable Types (SNVTs).

EASE OF USE and economy of installation were key design criteria. The WATTNODE PLUS' compact size permits installation inside of most electrical service panels and junction boxes. Detachable screw terminals make wiring a snap. The WATTNODE PLUS is line-powered and requires no separate power source.

ACCURACY of the WATTNODE PLUS is 0.5% of reading. Even with leading or lagging power factor and chopped or distorted wave forms, the WATTNODE PLUS measures true RMS power. This makes it ideal for monitoring motors and pumps controlled by variable speed drives or loads with switching power supplies.

THE COMPLETE LINE of WATTNODE PLUS models measures 1, 2, or 3 phases in 2, 3, or 4 wire configurations with nominal voltages from 120 to 600 VAC at 50/60 Hz. Select the current range of operation from our line of safe, low-voltage output, current transformers. Split-core or solid-core CTs measure currents up to 3000 Amps.

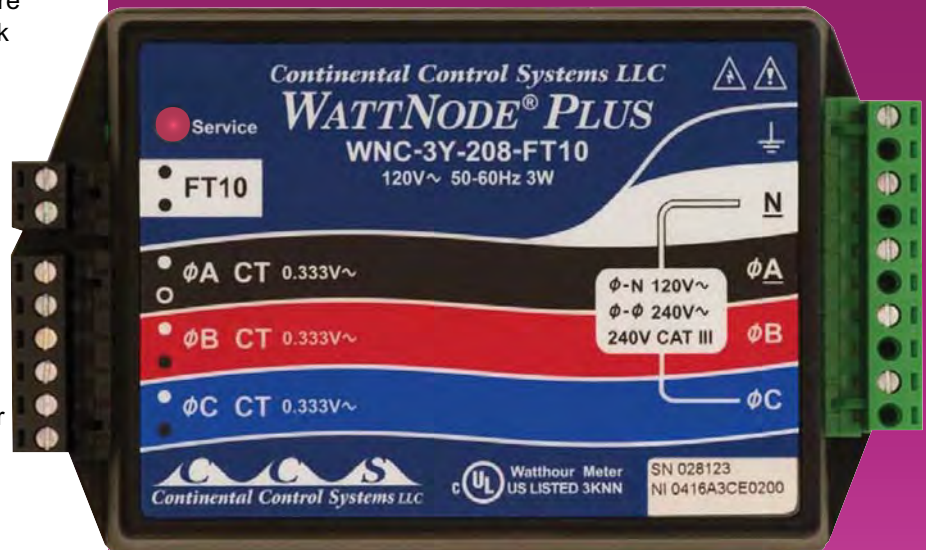

KWH

VOLTS

KVAR

PEAK DEMAND

DEMAND

KW

FREQUENCY

PF

AMPS

- Measures KW, KWH, Demand, KVAR, KVARH, PF, Amps, Volts, Frequency
Multiple measurements in one unit
- LonWorks Network Ready
Simple twisted-pair network installation, Internet accessible
- Compact Size
Fits inside of standard power panels and junction boxes
- LonWorks Interoperable
Easy to integrate into network
- Measures 1 ϕ , 2 ϕ , 3 ϕ Circuits
Flexible, field configurable
- Line Powered
No external power supply required

Specifications

WATTNODE[®] PLUS

AC Power Measurement for LonWORKS[®]

Quantities Measured

Energy: Real and Reactive
Power: Real and Reactive, per phase and average
Voltage: Per phase volts
Current: Per phase amps
Frequency: Phase A
Power Factor: Per phase and average
Demand: Block or sliding window
Peak Demand: Value and time

Quantities Retained during Loss of Power

Accumulated energy
Peak demand
Time of peak demand
Instrument configuration data

Measurement Configuration

Three phase: 3-wire or 4-wire
Single phase: 2-wire or 3-wire

LonWorks Interoperability

40 network variables using Standard
Network Variable Types (SNVTs):

Energy: SNVT_elec_whr_f
Power: SNVT_power_f
Voltage: SNVT_volts_f
Current: SNVT_amp_f
Power Factor: SNVT_pwr_fact_f
Frequency: SNVT_freq_f
Time: SNVT_time_stamp

User Controlled Inputs

Set CT size in amps
Set demand window type and period
Reset peak demand to zero
Set time of day

Accuracy

Power & Energy 0.45% of reading, plus 0.05% of full-scale

Electrical

Operating Voltage Range: 80% - 120% of nominal
Power Line Frequency Range: 45 to 65 Hz

Environmental

Temperature: -30^o C to 60^o C
Humidity: 5 to 90% RH (noncondensing)

Mechanical

Enclosure: High impact, UL rated, ABS plastic
Size: 3.3" x 5.6" x 1.5" (includes mounting tabs)
Connectors: Detachable screw terminals
(22-12 AWG)

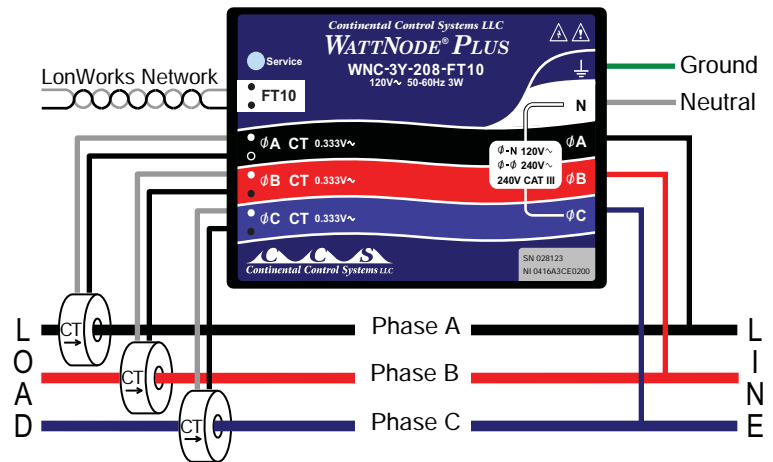

MADE IN THE USA

SPLIT CORE CURRENT TRANSFORMERS

SPLIT CORE current transformers make installation easier because they can be installed without disconnecting the circuit being measured. Split-core current transformers are available in a range of stock sizes and rated currents to meet your measurement

Model		Model		Model	
CTS-0750-(xxx) 0.75" I.D.		CTS-1250-(xxx) 1.25" I.D.		CTS-2000-(xxx) 2.00" I.D.	
Rated Amps	Model Suffix (xxx)	Rated Amps	Model Suffix (xxx)	Rated Amps	Model Suffix (xxx)
5	-005	70	-070	400	-400
15	-015	100	-100	600	-600
30	-030	150	-150	800	-800
50	-050	200	-200	1000	-1000
70	-070	250	-250	1200	-1200
100	-100	300	-300	1500	-1500
150	-150	400	-400		
		600	-600		

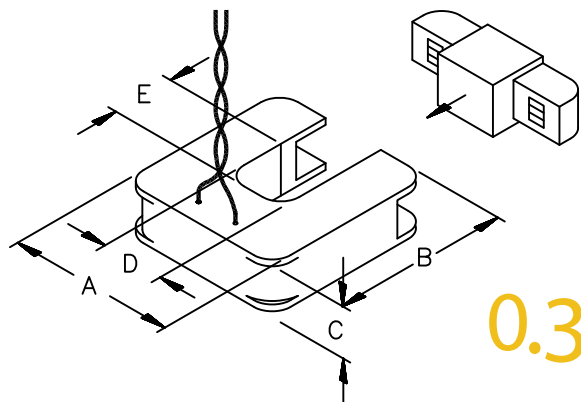

0.333 VAC Output

Size	CTS-0750	CTS-1250	CTS-2000
A	2.00 in. 5.08 cm	3.25 in. 6.45 cm	4.75 in. 12.1 cm
B	2.10 in. 5.33 cm	3.35 in. 8.51 cm	5.00 in. 12.7 cm
C	0.61 in. 1.55 cm	1.00 in. 2.54 cm	1.20 in. 3.05 cm
D	0.75 in. 1.91 cm	1.25 in. 3.18 cm	2.00 in. 5.08 cm
E	0.75 in. 1.91 cm	1.25 in. 3.18 cm	2.00 in. 5.08 cm



Split Core
Easy Installation



- No exposed metal parts on assembled transformer.
- Internal precision burden resistor across secondary.
- Epoxy encapsulated housing.
- Leads-8ft. twisted pair, 22 AWG.
- Core interleaved at joints for accuracy.
- Phase angle is measured at 50% of rated current.
- UL & CE recognized.
- Output is 0.333 VAC at rated current.
- Accuracy $\pm 1\%$ from 10% to 130% of rated current..
- Phase angle < 2 degrees for CTS-0750 models >70Amps & CTS-1250 models >150Amps.
- Snap closing/opening feature.
- Shrouded core blades for protection during installation.

Continental Control Systems

SOLID CORE current transformers are available in a range of sizes and rated currents to meet your measurement needs.

Model CTT-0300-(xxx) 0.30" I.D.		Model CTT-0500-(xxx) 0.50" I.D.		Model CTT-0750-(xxx) .075" I.D.	
Rated Amps	Model Suffix (xxx)	Rated Amps	Model Suffix (xxx)	Rated Amps	Model Suffix (xxx)
5	-005	15	-015	30	-30
15	-015	30	-030	50	-50
30	-030	50	-50	70	-70
		60	-60	100	-100

Model CTT-1000-(xxx) 1.00" I.D.		Model CTT-1250-(xxx) 1.25" I.D.	
Rated Amps	Model Suffix (xxx)	Rated Amps	Model Suffix (xxx)
50	-50	70	-070
70	-70	100	-100
100	-100	150	-150
150	-150	200	-200
200	-200	250	-250
		300	-300
		400	-400

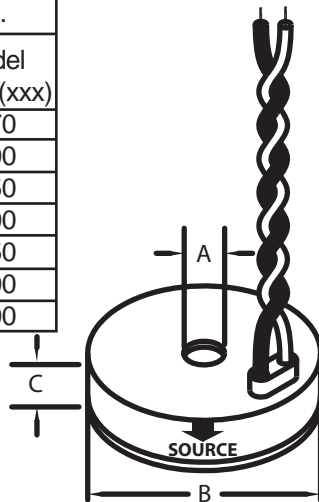

Series	Inside Diameter	Outside Diameter	Height
CTT-0300	0.30 in. 0.76 cm	1.70 in. 4.32 cm	0.75 in. 1.91 cm
CTT-0500	0.50 in. 1.27 cm	1.90 in. 4.83 cm	0.75 in. 1.91 cm
CTT-0750	0.75 in. 1.91 cm	2.10 in. 5.33 cm	0.75 in. 1.91 cm
CTT-1000	1.00 in. 2.54 cm	2.40 in. 6.10 cm	0.80 in. 2.03 cm
CTT-1250	1.25 in. 3.18 cm	2.70 in. 6.86 cm	0.80 in. 2.03 cm



SOLID CORE CURRENT TRANSFORMERS



Solid Core

0.333 VAC

- No exposed metal parts on assembled transformer.
- Internal precision burden resistor across secondary.
- Epoxy encapsulated housing.
- Leads-8ft. twisted pair, 22 AWG.
- Accuracy is specified from 10% to 130% of rated current.
- UL & CE recognized.
- Output is 0.333 VAC at rated current.
- Accuracy $\pm 1\%$.
- Phase angle < 1 degrees at 50% of rated current..
- The CTT family is designed for measuring service entrance and circuit currents where interruption during installation is permitted.

PX3 SERIES

Differential Pressure/Air Velocity Transducer



PX3

The PX3 transducer can measure either air pressure or velocity with the flip of a switch. The PX3 is available in three installation configurations: duct, panel or universal. Duct and panel models have two pressure and velocity options: 0-1" WC / 0-3,000 ft/min or 1-10" WC / 3,000-6,000 ft/min with four field-selectable sub-ranges. The universal model comes in one pressure/velocity range: 0-10" WC / 0-7,000 ft/min with seven field-selectable sub-ranges for pressure and eight for velocity. All variants are available with and without display. The PX3 has an IP65/NEMA 4 environmental rating and a 5-year limited warranty.

SPECIFICATIONS

GENERAL	
Media Compatibility	Dry air or inert gas
Input Power	Three-wire Volt mode: 24 Vac or 12-30 Vdc* Two-wire mA mode: 12-30 Vdc*
Output Power	Field-selectable: 2-wire, loop-powered 4-20 mA** (DC only, clipped and capped), 24 Vac/dc or 3-wire 0-5V/0-10V***

PRESSURE RANGES	
01 Pressure Range	Pressure Mode: Unidirectional: 0.1/0.25/0.5/1.0 in. WC FS, switch selectable Bidirectional: $\pm 0.1/\pm 0.25/\pm 0.5/\pm 1.0$ in. WC FS, switch selectable Unidirectional: 25 Pa/50 Pa/100 Pa/250 Pa, FS, switch selectable Bidirectional: ± 25 Pa/ ± 50 Pa/ ± 100 Pa/ ± 250 Pa, FS, switch selectable Velocity Mode: 500/1,000/2,000/3,000 ft/min 2.5/5/10/15 m/s
02 Pressure Range	Pressure Mode: Unidirectional: 1.0/2.5/5.0/10 in. WC FS, switch selectable Bidirectional: $\pm 1.0/\pm 2.5/\pm 5.0/\pm 10$ in. WC FS, switch selectable Unidirectional: 0.250 kPa/0.500 kPa/1.000 kPa/2.500 kPa, FS, switch selectable Bidirectional: ± 0.250 kPa/ ± 0.500 kPa/ ± 1.000 kPa/ ± 2.500 kPa, FS, switch selectable Velocity Mode: 3,000/4,000/5,000/6,000 ft/min 15/20/25/30 m/s

Reduce field failures

Excellent tolerance to overpressure & vibration reduces field failures

High accuracy

High accuracy digital sensor with seven selectable pressure and eight velocity sub-ranges, maintains calibration and reduces callbacks

Maintenance free

High reliability sensor technology for long-term, maintenance-free operation

Reduce setup

Selectable ranges and scales reduce setup time and number of models to stock

Water-resistant housing

IP65/NEMA 4 housing allows for mounting in wash-down locations

Circuit protection

Circuit protection avoids damage due to incorrect input wiring

APPLICATIONS

- Duct static pressure (Pressure mode)
- Building or room pressure (Pressure mode)
- Filter status (Pressure mode)
- Air flow measurement (Velocity mode)

05 Pressure Range	Pressure Mode: Unidirectional: 0.1/0.25/0.5/1.0/2.5/5/10 in. WC FS, switch selectable Bidirectional: $\pm 0.1/\pm 0.25/\pm 0.5/\pm 1.0/\pm 2.5/\pm 5/\pm 10$ in. WC FS, switch selectable Unidirectional: 25Pa/50Pa/100Pa/250Pa/0.5kPa/1kPa/2.5kPa FS, switch selectable Bidirectional: ± 25 Pa/50Pa/100Pa/250Pa/0.5kPa/1kPa/2.5kPa FS, switch selectable Velocity Mode: 500/1000/2000/3000/4000/5000/6000/7000 ft/min 2.5/5/10/15/20/25/30/35 m/s
-------------------	---

SENSOR	
Response Time	Standard: T95 in 20 sec, Fast: T95 in 2 sec, DIP switch selectable
Mode	Unidirectional or bidirectional, DIP switch selectable
Display (option)	Pressure mode: Signed 3-1/2 digit LCD, indicates pressure, overrange indicator Velocity mode: Signed 4-1/2 digit LCD, indicates velocity, overrange indicator
Proof Pressure	3 psid (20.6 kPa)
Burst Pressure	5 psid (34.5 kPa)
Pressure Mode Accuracy	$\pm 1\%$ FS (combined linearity and hysteresis)
Velocity Mode Accuracy	± 90 ft/min (± 0.45 m/s) plus 5% of measured value****
Temperature Effect	1" (250 Pa) models: 0.05%/°C; 10" (2.5 kPa) models: 0.01%/°C (Relative to 25 °C) 0 to 50 °C (32 to 122 °F)
Zero Drift (1-year)	1" (250 Pa) models: 2.0% max.; 10" (2.5 kPa) models: 0.5% max.



SPECIFICATIONS (CONT.)

Zero Adjust	Pushbutton auto-zero and digital input (2-pos terminal block)
Operating Environment	0 to 60 °C (32 to 140 °F)
Altitude of Operation	0 to 3000 m
Pollution Deg.	2
Humidity Range	100% RH, non-condensing
Mounting Location	For indoor use only.
Fittings	Brass barb; 0.24" (6.1 mm) o.d.
Environmental Rating	IP65, NEMA 4
Flammability Rating	UL 94 5VA fire retardant ABS, plenum rated

WARRANTY

Limited Warranty	5 years
------------------	---------

AGENCY APPROVALS



EMC Conformance: EN 61000-6-3 and A1 Class B, EN 61000-6-1.

* Class 2/II power source.

** Minimum input voltage for 4 to 20 mA operation: 250 Ω loop = 12 Vdc; 500 Ω loop = 19 Vdc.

*** Minimum load resistance for Volt operation: 5 kΩ.

**** For measured values between 200 and 7000 ft/min (1 and 35 m/s).

DIMENSIONAL DRAWING

in. (mm)

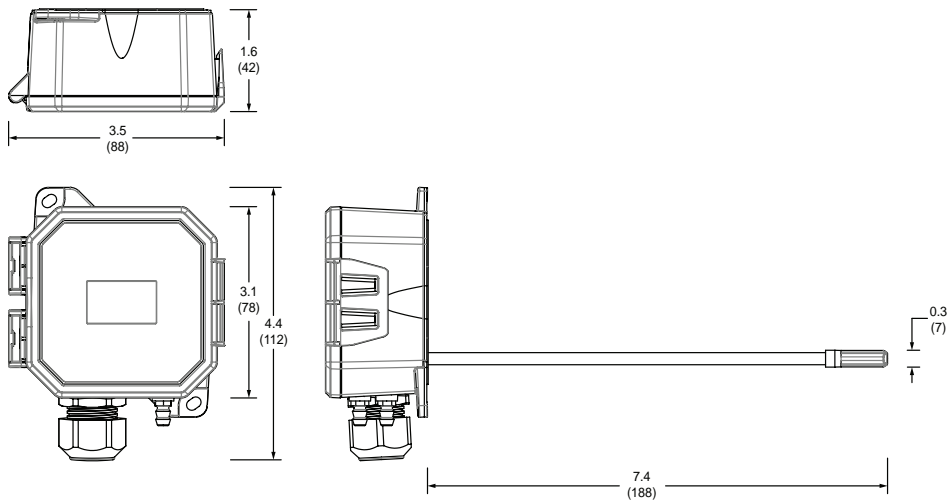

ORDERING INFORMATION

Enclosure	Local Display	NIST Certificate	Range
PX3 <input type="checkbox"/>	<input type="checkbox"/>	<input type="checkbox"/>	<input type="checkbox"/>
D = Duct P = Panel	L = LCD Display X = No Display	N = NIST X = None	01 = Pressure: 0 to 1 in. WC / 0 to 250 Pa Velocity: 0 to 3000 ft/min / 0 to 15 m/s 02 = Pressure: 0 to 10 in. WC/0 to 2500 Pa Velocity: 0 to 6000 ft/min / 0 to 30 m/s
Example: PX3 <input type="checkbox"/> D <input type="checkbox"/> L <input type="checkbox"/> X <input type="checkbox"/> 01			

WIRING DIAGRAM

2-wire, 4-20 mA Current Loop Output

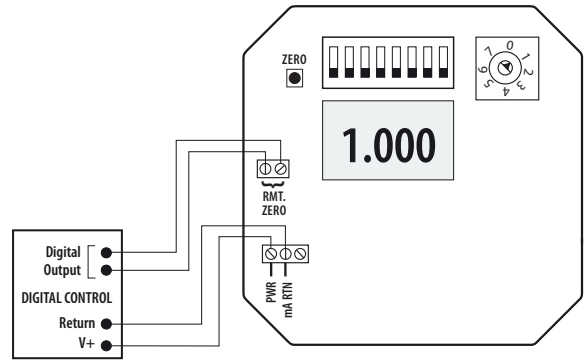

WIRING DIAGRAM

3-wire, 0-5 V/0-10 V Voltage Output

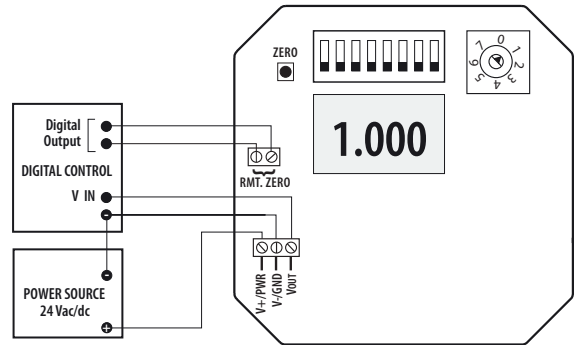

Air & Gas Pressure Switches



DBL

DESCRIPTION

Adjustable vacuum, pressure, and differential pressure switches for air and other non-combustible, non-aggressive gases.

APPLICATION

Air pressure control and monitoring of ducts, filters, fans and other devices in ventilation and air conditioning systems.

FEATURES

- Compact & easy to install
- High accuracy & life cycles
- Adjustable switching differential
- Calibrated, scaled setpoint knob



SPECIFICATIONS

Type of operation	On/Off, single-stage, micro switch
Output	1 SPDT, 250 VAC, 1.0 (0.4) A
Trip/setpoint	Internal linearly scaled knob
Switching differential	Screw adjustable
Sensing techniques	2 pressure chambers separated by diaphragm
Diaphragm material	Silicone
Life cycles	1,000,000
Permissible ambient temperature	
- Working/Storage	-4°F to 185°F (-20°C to 85°C)
Wire	
- Connection	Spade
- Size	Maximum 16 AWG (1.5 mm ²)
Cable entry	1/2" NPT conduit connection
Housing	
- Material	Base = PA 6.6 – Cover = Polystyrene
- Color	Transparent
- Protection	NEMA 3 (IP 54)
- Dimensions	Diameter 4.0 x 2.3 in. (100 x 58 mm)
Installation	Surface mounted
Pressure port connection	
- Diameter	2 for PVC tube, P1 (+) and P2 (-) 0.236" (6 mm) for O.D. 3/16" (8 mm) push-on tubing
Ship weight	0.4 lb (0.2 kg)

certified ISO 9001



"Setpoint can be adjusted without field gauge reading"



Adj. Setpoint Range* Inch WC (Pa)	Adj. Switching Diff.** Inch WC (Pa)	Max. Operation Pressure Inch WC (kPa)	Scale Type	Part Number
0.08 to 0.8 (20 to 200)	0.04* to 0.08 (10 to 20)	40 (10)	930.80	DBL-205L
0.16 to 0.4 (40 to 100)	0.08* to 0.16 (20 to 40)	40 (10)	930.81	DBL-205
0.16 to 0.8 (40 to 200)	0.08* to 0.16 (20 to 40)	40 (10)	930.82	DBL-205A
0.20 to 2.0 (50 to 500)	0.08* to 0.16 (20 to 40)	40 (10)	930.83	DBL-205B
0.80 to 4.0 (200 to 1000)	0.40* to 0.80 (100 to 200)	40 (10)	930.85	DBL-205D
2.0 to 10.0 (500 to 2500)	0.60* to 1.20 (150 to 300)	40 (10)	930.86	DBL-205E
Kit: (2) Pitots, (2) Grommets, 6.5ft. (2.0 m) Tubing				DBZ-06

* The adjustable trip/setpoint within the control range is calibrated for vertical mounting position pressure, port connection pointing downwards. If mounted in horizontal position, deduct 0.08 inch WC (20 Pa) from desired setpoint for off-set adjustment. If setpoint at the bottom of range, do not mount DBL in horizontal position.

** Factory set switching differential is ± 15% of trip/setpoint.

WIRING DIAGRAM

DBL

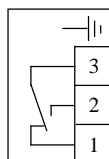

Ground
 3 — Common
 2 — NO
 1 — NC

Pressure increase, contact connection: 3 to 2
 Pressure decrease, contact connection: 3 to 1
 Pressure port P₁⁽⁺⁾ = high pressure
 Pressure port P₂⁽⁻⁾ = low pressure

DBL PRESSURE SWITCH INSTALLATION

DBL-Install

Mounting position

Mounting the switch in the vertical position, with the pressure port connection pointing downwards (figure 1).

If mounted in horizontal position, deduct 0.08 inch WC (20 Pa) from desired setpoint for offset adjustment. If the setpoint is at the bottom of the range, do not mount the pressure switch in the horizontal position. Never install the switch where the setpoint knob faces downward. This will cause incorrect switch performance.

Surface mounting

Mount with four screws through bracket (figure 2). Do not tighten the screws excessively. It could deform the pressure switch and lead to air leakage.

Duct air pick-up

To insure good airflow to the pressure switch, it is suggested to use the tubing and pitot kit DBZ-06 (figure 3).

Pressure port connections

Pressure port P1 (+) = high pressure, it is located on the lower part of the housing base. Pressure port P2 (-) = low pressure, it is located on the upper part of the housing base (figure 4).

Electrical connection and switching function

Electrical wiring connections must be done per local building and electrical codes. The DBL data sheet will provide all appropriate data for the control relay and output switching.

Control settings

Do not adjust the setpoint knob or screw adjustment for the switching differential (figure 5) when high voltage power is connected to the pressure switch. For setpoint setup and switching differential data, refer to DBL data sheet.

Housing cover installation

Mount housing cover (figure 6) prior to operating the pressure switch.

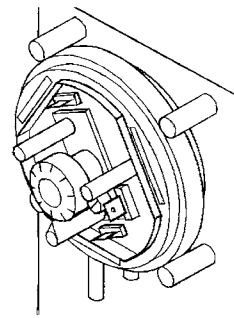
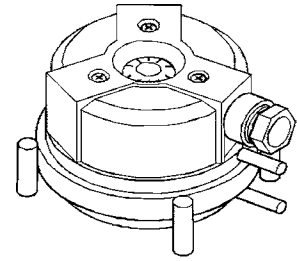

Figure 1

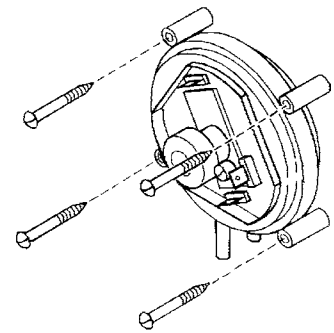

Figure 2

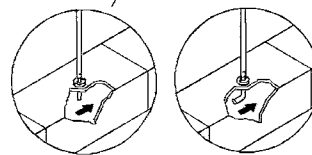
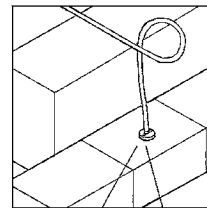

Figure 3

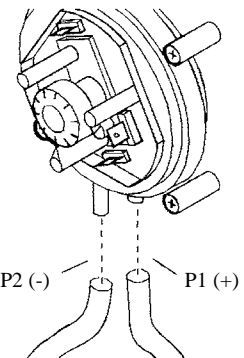

Figure 4

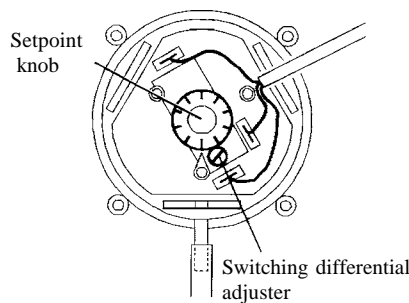

Figure 5

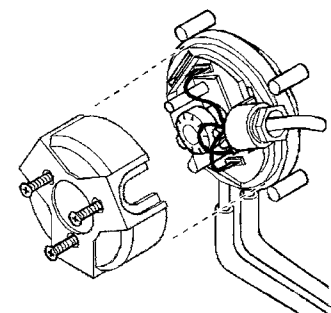

Figure 6



CI-24



WattStopper Occupancy Sensor

The CI-24 occupancy sensor for lighting applications, specifically designed to interface with Building Automation Systems, BAS, through an internal isolated relay. The ceiling-mount passive infrared occupancy sensor has a user-adjustable time delay (30 seconds to 30 minutes). It may be programmed through DIP switches to prevent unnecessary cycling. The CI-24 includes a built-in override switch. Two levels of sensitivity are also selectable through DIP switches. The four-level patented Fresnel lens allows the CI-24 to cover up to 1200 ft² (111.48 m²).

Features

- Advanced PIR technology
- Adjustable time delay
- Adjustable sensitivity
- Contains isolated relay for use with BAS and other control systems
- Patented Fresnel lens
- 360° coverage up to 1200 ft² (111.48m²)
- Red LED indicates occupancy detection
- Five-year warranty
- Manual override switch

Specifications

Supply Voltage: 24 VAC/DC ±10% 37 mA

Contact Rating:1A @ 24 VAC/DC, 1/2A @ 120 VAC

Coverage Pattern:360 degrees up to 1200 ft2 (111.48 m2)

Time Delay Adjust:Digital (DIP switch setting) for 30 seconds, 10 minutes, 20 minutes, or 30 minutes

Operating Temperature:32° to 98°F (0° to 36°C)

Mounting:2.75" to 3" hole in ceiling

Color:White

Dimensions:3.3" dia x 2.2" deep (8.5 x 5.6 cm), protrudes approximately 0.4 from ceiling surface

Approvals:cUL listed UL Listed file E101196

Weight:1.0 lb (0.46 kg)

Certifications





FS105, FS108, FS116

ProSafe™ 10/100 Desktop Switches

- *Help is there when you need it! NETGEAR provides 24x7 technical support* in English, with selected local language support during office hours.*

- NETGEAR's popular FS100 series desktop switches, known for their reliability and performance, provide your LAN with high-speed, 10/100 Mbps auto-sensing connectivity for as many as 5, 8, or 16 users. Just plug in your Ethernet cables, connect a power cord, and you're ready to go—there's no software to configure. They negotiate to the fastest possible connection and with Auto Uplink™ technology, these switches automatically figure out if the link needs a straight-through or cross-over connection, and makes the right choice. Existing 10BASE-T devices are easily integrated within higher bandwidth environments, with full wire speeds on all ports of either 10 Mbps or 100 Mbps. Engineered without the need for internal fans, they operate silently. And each of these very compact switches is housed in a sturdy metal case for years of dependable use.

When you want solid network performance for your growing business, plus the added benefit of quiet operation, NETGEAR's ProSafe FS105, FS108, and FS116 are your best choices for quality, convenience, and smooth — running usability — all at very affordable prices.

- At Your Service** ● Five, eight, or sixteen ports provide LAN access for many users. Every port supports up to 200 Mbps in dedicated bandwidth and traffic is forwarded flawlessly with automatic flow control.
- Compact** ● Solidly built in small sizes that are easy to position when space is at a premium. Ideal for conference rooms, class rooms, study groups or small offices. Place it on any flat surface or use the included wall mount kit to tuck it out of the way.
- Simple To Use** ● Once you connect the hardware, your switch is operating! Auto negotiation takes care of the speed and duplex, while Auto Uplink takes care of the MDI/MDI-X connection. Eliminate the need for toggle switches or special crossover cables.
- Quiet** ● No fan means no noise, which helps maintain a peaceful atmosphere in your busy office.

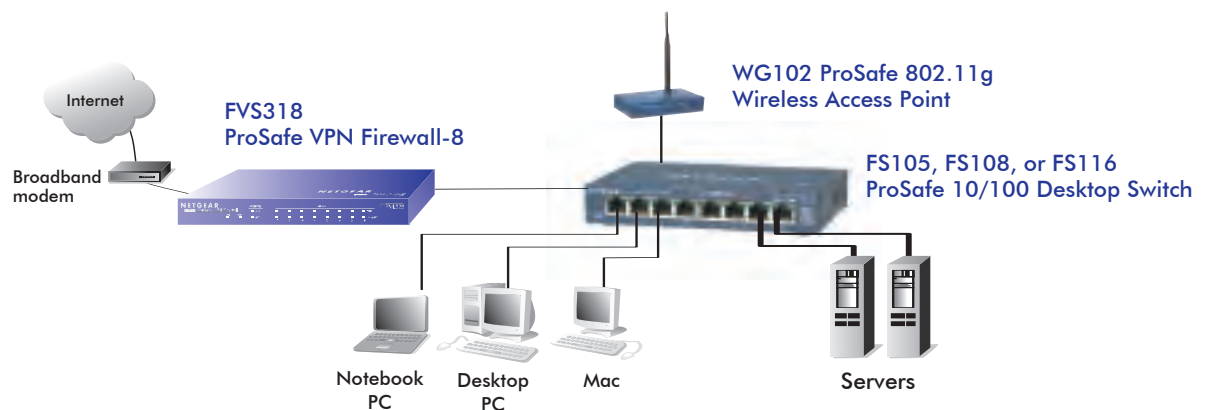

Technical Specifications

- **Network Ports:**
 - FS105: Five (5) auto speed-sensing UTP ports
 - FS108: Eight (8) auto speed-sensing UTP ports
 - FS116: Sixteen (16) auto speed-sensing UTP ports
- **Standards Compliance:**
 - IEEE 802.3 10BASE-T Ethernet
 - IEEE 802.3u 100BASE-TX Fast Ethernet
 - IEEE 802.3x Full-duplex Flow Control
- **Performance Specifications**
 - Forwarding modes: Store-and-forward
 - Bandwidth:
 - FS105: 1Gbps
 - FS108: 1.6 Gbps
 - FS116: 3.2 Gbps
 - Network latency: Less than 20 μs for 64-byte frames in store-and-forward mode for 100 Mbps to 100 Mbps transmission
 - Buffer memory:
 - FS105: 64 KB
 - FS108: 96 B
 - FS116: 512 KB
 - Address database size:
 - FS105: 1,000
 - FS108: 1,000
 - FS116: 8,000
 - Addressing: 48-bit MAC address
 - Mean Time Between Failure (MTBF):
 - FS105: 390,000 hours (~40 years)
 - FS108: 168,300 hours (~19 years)
 - FS116: 194,000 hours (~22 years)
- **Environmental Specifications**
 - Operating temperature: 32 to 104°F (0 to 40° C)
 - Storage temperature: 14 to 158°F (-10 to 70°C)
 - Operating humidity: 90% maximum relative humidity, non-condensing
 - Storage humidity: 95% maximum relative humidity, non-condensing
 - Operating altitude: 10,000 ft (3,000 m) maximum
 - Storage altitude: 10,000 ft (3,000 m) maximum
- **Safety Agency Approvals**
 - UL listed (UL 1950)/cUL
 - IEC950/EN60950

- **Status LEDs:**
 - Power
 - Link, speed, and activity indicators built into each RJ-45 port
- **Electromagnetic Emissions:**
 - CE mark, commercial
 - FCC part 15 Class A
 - EN55 022 (CISPR22), Class A
 - VCCI Class A
 - C-Tick
- **AC Power:**
 - FS105: 7.5W (7.5VDC, 1A)
 - FS108: 7.5 W (7.5VDC, 1A)
 - FS116: 14.4W (12VDC, 1.2A)
- **Physical Specifications:**
 - FS105**
 - **Dimensions:** 3.7 x 4.1 x 1.1 in (94 x 103 x 27 mm)
 - **Weight:** 0.62 lbs (0.28 kg)
 - FS108**
 - **Dimensions:** 6.2 x 4.1 x 1.1 in (158 x 103 x 27 mm)
 - **Weight:** 1.1 lbs (0.49 kg)
 - FS116**
 - **Dimensions:** 11.3 x 4.1 x 1.1 in (287 x 103 x 27 mm)
 - **Weight:** 2.0 lbs (0.9 kg)
- **Warranty:**
 - 5 years for unit
 - 2 years for power adapter

Related NETGEAR ProSafe Products

- GS105 5-port Gigabit Switch
- GS108 8-port Gigabit Switch
- GS116 16-port Gigabit Switch
- GA311 32-bit Gigabit PCI Adapter
- GA511 PC Gigabit Adapter
- FA311 32-bit 10/100 PCI Adapter
- FA511 PC Card 10/100 Adapter

Package Contents

- 10/100 Desktop Switch
- Wall-mount kit
- AC adapter
- Quick Installation Guide
- Warranty/Support information card

System Requirements

- Network card for each PC (e.g. NETGEAR FA311)
- Network Cables
- Network card for each PC or server
- Network software (e.g., Windows®, Linux®, Mac OS®)



©2005 NETGEAR, Inc. NETGEAR®, the Netgear Logo, Auto Uplink, ProSafe, and Everybody's connecting are trademarks or registered trademarks of Netgear, Inc. in the United States and/or other countries. Microsoft, Windows, and the Windows logo are trademarks or registered trademarks of Microsoft Corporation in the United States and/or other countries. Other brand and product names are trademarks or registered trademarks of their respective holders. Information is subject to change without notice. All rights reserved.

* Free basic installation support provided for 90 days from date of purchase. Advanced product features and configurations are not included in free basic installation support; optional premium support available.



About Copeland

Copeland, a global provider of sustainable climate solutions, combines category-leading brands in compression, controls, software and monitoring for heating, cooling and refrigeration. With best-in-class engineering and design and the broadest portfolio of modulated solutions, we're not just setting the standard for compressor leadership; we're pioneering its evolution. Combining our technology with our smart energy management solutions, we can regulate, track and optimize conditions to help protect temperature-sensitive goods over land and sea, while delivering comfort in any space. Through energy-efficient products, regulation-ready solutions and expertise, we're revolutionizing the next generation of climate technology for the better. For more information, visit copeland.com.

For Technical Support call 833-409-7505 or email ColdChain.TechnicalServices@Copeland.com

The contents of this publication are presented for informational purposes only and they are not to be construed as warranties or guarantees, express or implied, regarding the products or services described herein or their use or applicability. Copeland reserves the right to modify the designs or specifications of such products at any time without notice. Responsibility for proper selection, use and maintenance of any product remains solely with the purchaser and end-user.