

# H-Series Condensing Unit User Manual



**COPELAND**™

  
**EMERSON**™

# Table of Contents

Content	Page
Introduction	3
Safety Information	4
Nomenclature	6
CDU Models & Data	6
Features & Benefits	7
Physical Layout	8
Dimensional Drawings	9
Electrical Connections	10
Installation & Startup	14
Operational Checklist	20

## Introduction

Thank you for purchasing the Emerson™ H-Series Condensing Unit. We hope that this product meets your intended refrigeration requirement. Please read through this operation manual to familiarize yourself with the installation, commissioning, and operation of this product. Please do read the following information in this page before proceeding with the rest of the manual.

The Emerson™ H-Series scroll refrigeration condensing units should only be installed by suitably qualified and experienced refrigeration technicians. No responsibility can be accepted for damage caused by inexperienced or inadequately trained site technicians or improper system design. All instructions and procedures described in this manual are based on good refrigeration trade practices as applicable to this particular product. The installation contractor may prefer to use variations to these recommendations. However, the methods described in this manual represent the minimum requirements to avoid any subsequent warranty claims for this equipment and its components. These instructions do not cover the fundamentals of good electrical or refrigeration practice and are therefore intended for use only by qualified and/or experienced personnel or technicians.

For any additional query, please consult your local sales office, quoting unit model and serial number as shown on the nameplate. In case of ambiguity, the wiring diagram supplied with each unit takes precedence over the diagram in this manual.

Emerson H-Series Condensing Units are fitted with high efficient Copeland Scroll Compressor and the Dual Temperature Condensing Units are fitted with high efficient ZFI Copeland Scroll compressors with vapor injection technology.







This document is designed to help the contractor and customer for the installation, commissioning & operation of Emerson's H-Series Condensing Unit.

# 1. Safety Information

1.1 Installation and commissioning work on CDU shall be carried out only by qualified, refrigeration personnel who have been trained and instructed.

1.2 H-Series condensing unit is manufactured according to the latest safety standards. Emphasis has been placed on the user's safety. For relevant standards please refer to the manufacturer's declaration, available on request. You are strongly advised to follow these safety instructions.

## 1.3 Icon explanation

 <b>WARNING</b> This icon indicates instructions to avoid personal injury and material damage.	 <b>CAUTION</b> This icon indicates instructions to avoid property damage and possible personal injury.
 <b>High voltage</b> This icon indicates operations with a danger of electric shock.	 <b>IMPORTANT</b> This icon indicates instructions to avoid malfunction of the compressor.
 <b>Danger of burning or frostbite</b> This icon indicates operations with a danger of burning or frostbite.	<b>NOTE</b> This word indicates a recommendation for easier operation.
 <b>Explosion hazard</b> This icon indicates operations with a danger of explosion.	

## 1.4 Safety Statements

- Only qualified and authorized refrigeration personnel are permitted to install, commission and maintain this equipment.
- Electrical connections must be made by qualified electrical personnel.
- All valid standards for connecting electrical and refrigeration equipment must be observed.
- The national legislation and regulations regarding personnel protection must be observed.



Use personal safety equipment. Safety goggles, gloves, protective clothing, safety boots and hard hats should be worn where necessary.

## 1.5 General Instructions



### Warning

**System breakdown! Personal injuries!** Never install a system in the field and leave it unattended when it has no charge, a holding charge, or with the service valves closed without electrically locking out the system.

**System breakdown! Personal injuries!** Only approved refrigerants and refrigeration oils must be used.



### Warning

**High shell temperature! Burning!** Do not touch the compressor until it has cooled down. Ensure that other materials in the area of the compressor do not get in touch with it. Lock and mark accessible sections.



### Caution

**Overheating! Bearing damage!** Do not operate compressors without refrigerant charge or without being connected to the system.



### Caution

Compressors contain oil & refrigerant under pressure. Release pressure from both high & low side of compressor before servicing.



### Caution

Tube brazing & compressor operation can produce hot surfaces. To avoid burns, allow surfaces to cool.

## 1.6 Safety Refrigerants/Lubricant

- a. Please use correct refrigerant as designed to work in safe operating envelope.
- b. Compressor is supplied with an initial oil charge. The standard oil charge for use with HFC refrigerant is polyol ester (POE) lubricant Emkarate RL 32 3MAF.

## 2. Nomenclature

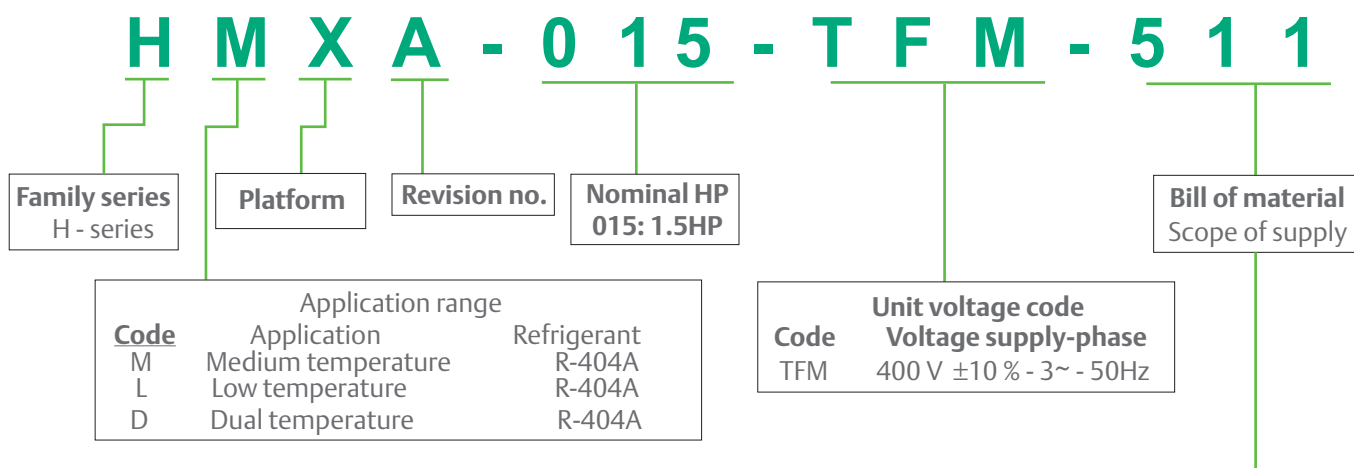

**511** Filter drier, Moisture Indicator, Liquid receiver, Suction & Liquid Line Service Valves, HP Cutout, Adjustable LP Cutout.  
**513** Filter drier, Moisture Indicator, Liquid receiver, Suction & Liquid Line Service Valves, HP Cutout, Adjustable LP Cutout, Oil separator, Suction accumulator, Coresense / Injection Management Module, Sub cooler, Vapour injection Expansion valve.

## 3. Models

### Mechanical data

Condensing Unit	Compressor model	Receiver Capacity (l)	Air Flow (m <sup>3</sup> /s)	Dimensions Depth/Width/Height (mm)	Suction Size	Liquid Size	Net Weight
HMXA-015-TFM-511	ZS11KAE-TFD-600	4.6	2922	1029 x 424 x 840	3/4"	1/2"	81
HLXA-015-TFM-511	ZF06KAE-TFD-618	4.6	2922	1029 x 424 x 840	3/4"	1/2"	81
HMXA-020-TFM-511	ZB15KQE-TFD-558	4.6	2922	1029 x 424 x 840	3/4"	1/2"	85
HLXA-020-TFM-511	ZF09KAE-TFD-618	4.6	2922	1029 x 424 x 840	3/4"	1/2"	82
HDXA-030-TFM-513	ZF109KQE-TFD-550	4.6	2922	1029 x 424 x 840	3/4"	1/2"	85
HDXA-040-TFM-513	ZF113KQE-TFD-550	4.6	2922	1029 x 424 x 840	3/4"	1/2"	91
HDXA-050-TFM-513	ZF117KQE-TFD-550	6.7	5910	1029 x 424 x 1242	7/8"	1/2"	106
HDXA-065-TFM-513	ZF121KQE-TFD-550	6.7	5910	1029 x 424 x 1242	7/8"	1/2"	120
HDXA-075-TFM-513	ZF123KQE-TFD-550	6.7	5910	1029 x 424 x 1242	7/8"	1/2"	125

## Electrical data

Condensing Unit	Compressor model	Unit MOC	Compressor			Total Fan Current
			LRA	MOC	RLA	
HMXA-015-TFM-511	ZS11KAE-TFD-600	4.2	27.0	3.3	4.3	0.9
HLXA-015-TFM-511	ZF06KAE-TFD-618	5.1	28.0	4.2	3.8	0.9
HMXA-020-TFM-511	ZB15KQE-TFD-558	5.8	26.0	4.9	5.0	0.9
HLXA-020-TFM-511	ZF09KAE-TFD-618	6.2	41.6	5.3	4.9	0.9
HDXA-030-TFM-513	ZFI09KQE-TFD-550	6.2	23.5	5.3	4.9	0.9
HDXA-040-TFM-513	ZFI13KQE-TFD-550	7.5	40.0	6.6	6.4	0.9
HDXA-050-TFM-513	ZFI17KQE-TFD-550	9.8	50.0	8.1	6.9	1.7
HDXA-065-TFM-513	ZFI21KQE-TFD-550	12.6	64.0	10.9	8.9	1.7
HDXA-075-TFM-513	ZFI23KQE-TFD-550	14.1	74.0	12.4	10.6	1.7

## 4. Features and Benefits

Features	Benefits
Efficiency	High efficiency Copeland™ ZFI Vapor injection compressors for Dual temperature application. Vapor injection technology improves system capacity by up to 30% and efficiency by up to 20%. New valving technology adjusts the scroll compression ratio based on operating condition, significantly improving performance. Specially designed condenser.
Reliability	Compressor is provided with Emerson EVI CoreSense™ kits to control superheat of vapor injection and to maintain safe discharge temperature in dual temperature application. Fully featured options such as filter drier, sight glass, oil separator and suction accumulator available as standard scope of supply in dual temperature models. Compressors are supplied with internal thermal protectors that safeguards against motor overheating and high current.
Envelope	Unique operating envelope (-40°C to 7°C evaporating temperatures) and up to 49°C ambient, providing a broad range of selection (dual temp application).
Smooth Operation	Scroll compressor has an inbuilt check valve that isolates high pressure gas, allowing the compressor to start unloaded with low inrush currents. Less vibration.
Inventory	Same units for both medium and low temperature requirements for majority of the capacities resulting in rationalization of unit inventory.
Maintenance	Optimal layout of components for easy serviceability. Pre-wired electric junction box, liquid receiver, HP safety cartridge switch and adjustable LP control switch.
Multi-evaporator	One condensing unit could be connected to two evaporators. The lowest load operation should be more than 35 of the total load.

## Condenser

Internally grooved copper tubes with hydrophilic coated aluminum fins.

## Fan Motors

Thermally protected, single-phase fans. Option to have fan speed controller.

# 5. Physical Layout of the Dual Temperature Unit

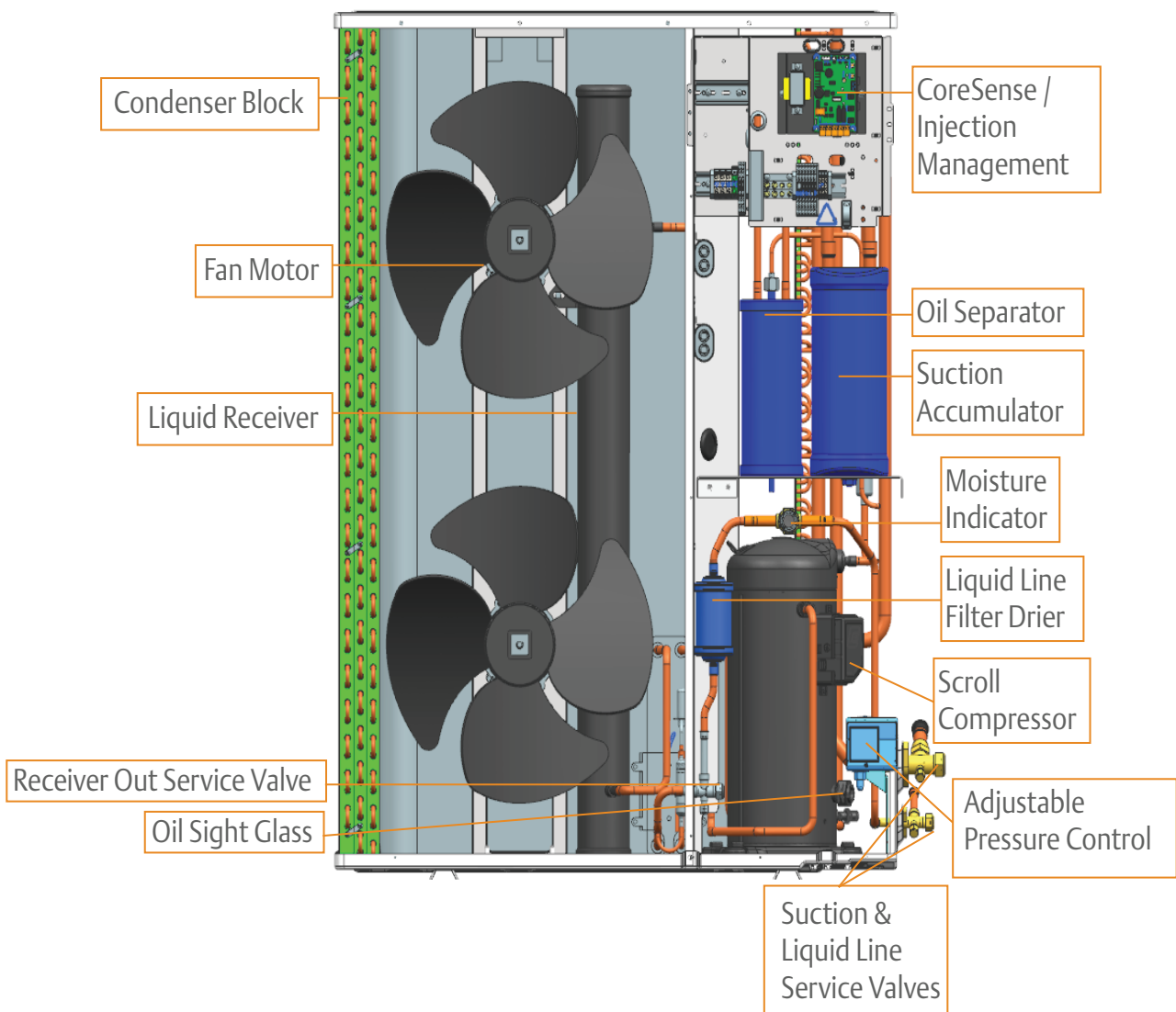



## 6. Dimensional drawings

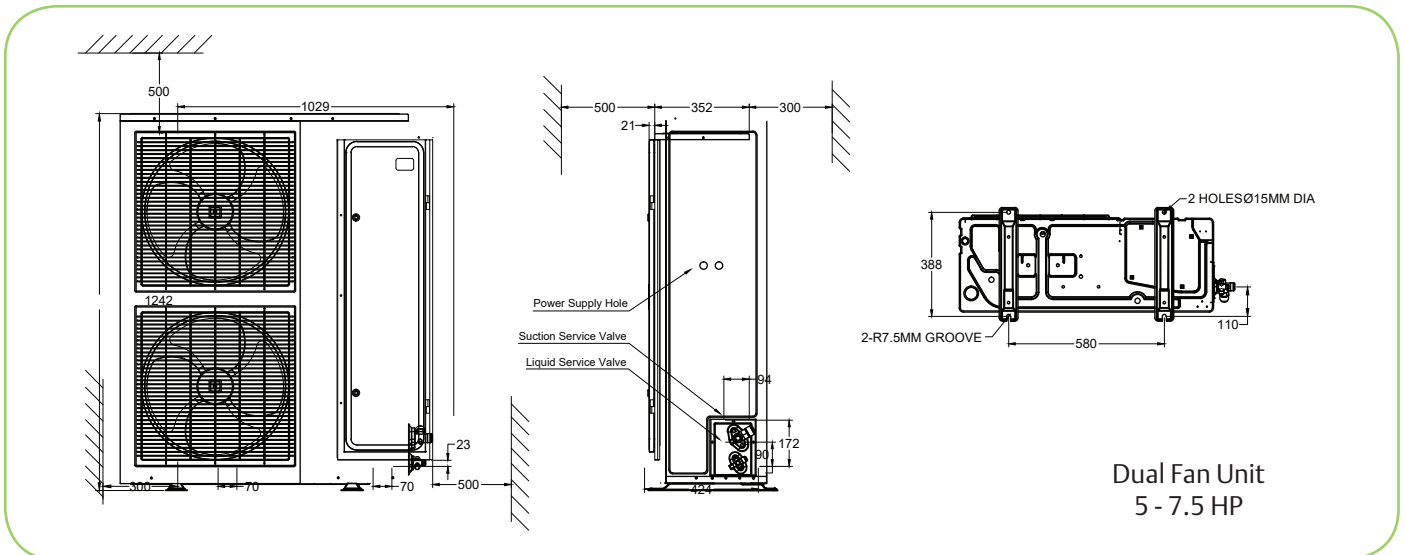
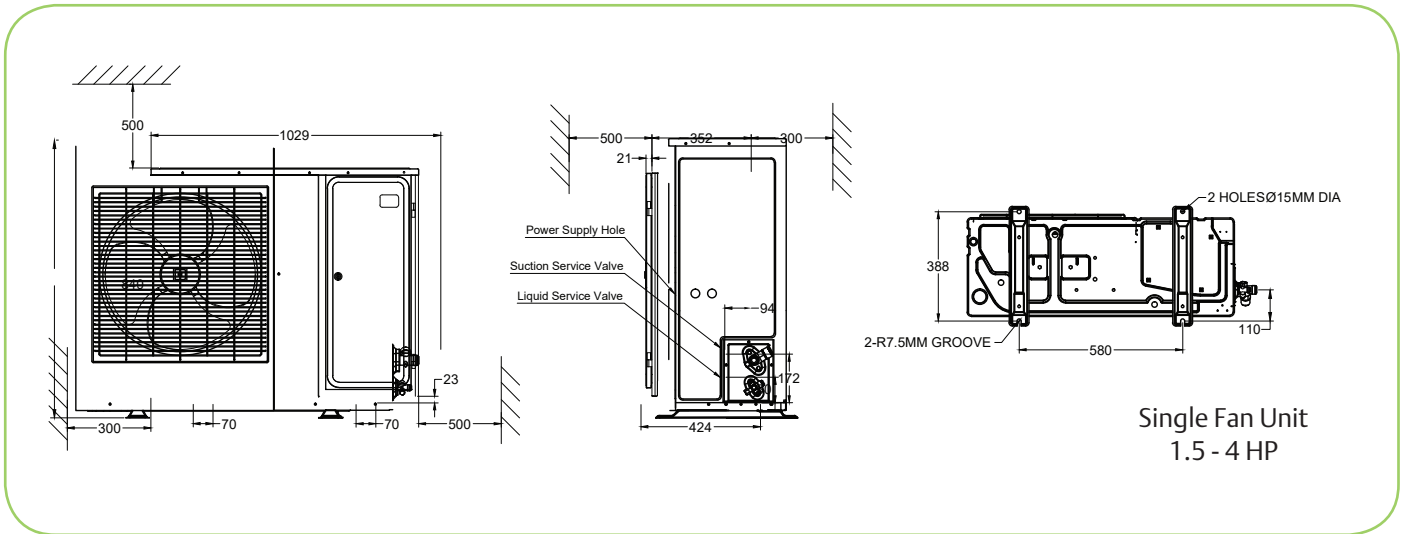

## 7. Scope of supply

**511 (HL & HM Units)** Filter drier, Moisture Indicator, Liquid receiver, Suction & Liquid Line Service Valves, HP Cutout, Adjustable LP Cutout.

**513 (HD Units)** Filter drier, Moisture Indicator, Liquid receiver, Suction & Liquid Line Service Valves, HP Cutout, Adjustable LP Cutout, Oil separator, Suction accumulator, CoreSense / Injection Management Module, Sub cooler, Vapour injection Expansion valve.

# 8. Electrical connections

<p><b>H Series Condensing Unit</b></p> <p>Compressor ZFI-TFD</p> <p>L-N 230 ± 10% V/1/50HZ</p> <p>L1-L2-L3 400 ± 10% V/3/50HZ</p>	<p>TFM</p> <p>ZFI-TFD</p> <p>230 ± 10% V/1/50HZ</p> <p>400 ± 10% V/3/50HZ</p>	<p>TF7</p> <p>ZFI-TF7</p> <p>220 ± 10% V/1/60HZ</p> <p>380 ± 10% V/3/60HZ</p>	<p><b>052-3452-01</b></p> <p>Rev 00</p>												
<p><b>Remarks:</b></p> <p>A1 = CoreSense Module For M1</p> <p>A5 = Terminal Box Compressor</p> <p>C1 = Run Capacitor M21/M22</p> <p>F1 = High Pressure Control</p> <p>F2 = Low Pressure Control</p> <p>K1 = Contactor M1</p> <p>K6 = Relay Unit Alarm (If Fitted)</p> <p>K7 = Voltage Free Relay Contact For Alarm Device</p> <p>M1 = Compressor Motor</p> <p>M21 = Fan Motor / Condenser</p> <p>M22 = Fan Motor / Condenser</p> <p>R2 = Crankcase Heater</p> <p>TF = CoreSense Transformer</p> <p>FSC = Fan Speed Controller</p> <p>S = Mid Coil NTC Sensor</p>															
<p><b>Notes:</b></p> <p>1. Dashed Line "----" Is Wired By Installer</p> <p>2. For FSC Installation; Remove Wire 3 &amp; 4 From Terminal N &amp; 3. Connect These Wires To FSC Terminal 1 &amp; 3. Install Wire Harness 1 &amp; 2 Supplied With Kit As Per Drawing. Connect NTC Sensor (S) To FSC Terminal 23 &amp; 24</p> <p>3. Set The FSC Trimmer To Complete The Installation</p>															
<p><b>Typical Control Circuit</b></p>															
<p><b>FSC Trimmer Setting</b></p> <p>SET 40</p> <p>DIFF. 10</p> <p>MINIMUM SPEED 50</p> <p>CUT OFF 30</p>															
<p><b>A1 Dip-Switch Default Factory Setting</b></p> <table border="1" style="width: 100%; border-collapse: collapse;"> <tr> <td>SW1</td> <td>SW2</td> <td>SW3</td> </tr> <tr> <td style="text-align: center;">1 2</td> <td style="text-align: center;">1 2</td> <td style="text-align: center;">1 2</td> </tr> <tr> <td style="text-align: center;">BIT1-ON</td> <td style="text-align: center;">BIT2-OFF</td> <td style="text-align: center;">BIT1-OFF</td> </tr> <tr> <td style="text-align: center;">BIT2-ON</td> <td style="text-align: center;">BIT1-ON</td> <td style="text-align: center;">BIT2-ON</td> </tr> </table>				SW1	SW2	SW3	1 2	1 2	1 2	BIT1-ON	BIT2-OFF	BIT1-OFF	BIT2-ON	BIT1-ON	BIT2-ON
SW1	SW2	SW3													
1 2	1 2	1 2													
BIT1-ON	BIT2-OFF	BIT1-OFF													
BIT2-ON	BIT1-ON	BIT2-ON													
<p><b>Colour Legend</b></p> <p>RD = Red</p> <p>YE = Yellow</p> <p>BU = Blue</p> <p>BK = Black</p> <p>WH = White</p> <p>GR = Green</p> <p>GY = Grey</p> <p>OG = Orange</p> <p>BN = Brown</p> <p>GY = Green / Yellow</p>															

H Series Condensing Unit	TFM	TF7	<b>052-3452-02</b>
Compressor	ZF1-TF7	ZF1-TF7	
L-N	230 ± 10% V/1/50HZ	220 ± 10% V/1/60HZ	
L1-L2-L3	400 ± 10% V/3/50HZ	380 ± 10% V/3/60HZ	
			Rev 00

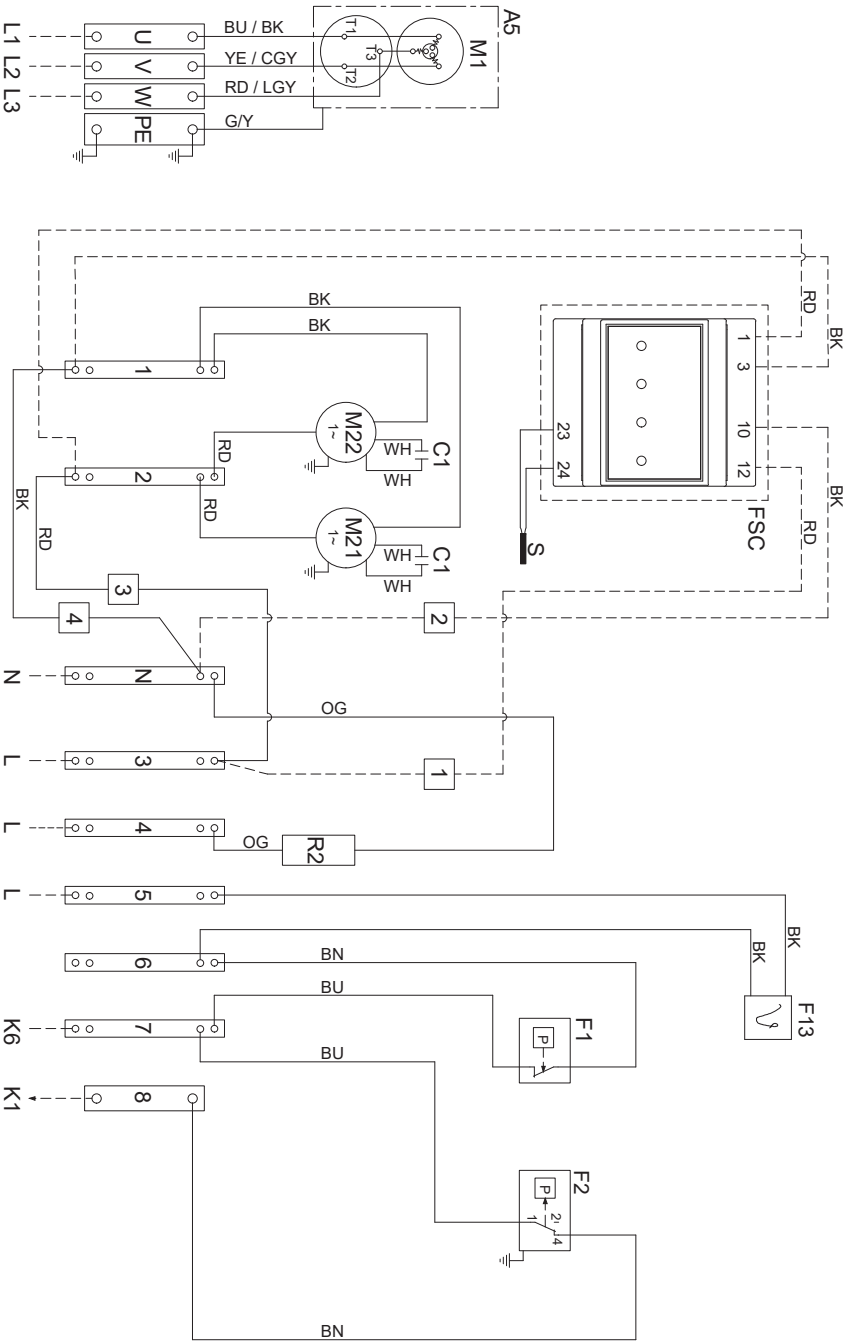

**Typical Control Circuit**

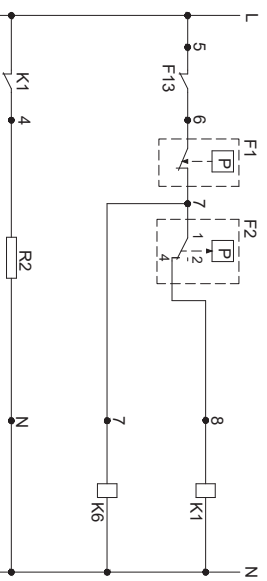

**FSC Trimmer Setting**

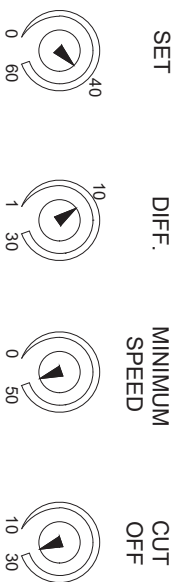

**Colour Legend**

RD = Red
YE = Yellow
BU = Blue
BK = Black
WH = White
CGY = Charcoal Grey
LGY = Light Grey
OG = Orange
BN = Brown
GY = Green / Yellow

- Remarks:
- A5 = Terminal Box Compressor
  - C1 = Run Capacitor M21/M22
  - F1 = High Pressure Control
  - F13 = Discharge Gas Thermostat (If Fitted)
  - F2 = Low Pressure Control
  - K1 = Contactor M1
  - K6 = Relay Unit Alarm (If Fitted)
  - M1 = Compressor Motor
  - M21 = Fan Motor / Condenser
  - M22 = Fan Motor / Condenser
  - R2 = Crankcase Heater
  - TF = CoreSense Transformer
  - FSC = Fan Speed Controller
  - S = Mid Coil NTC Sensor
- Notes:
1. Dashed Line "----" is Wired By Installer
  2. For FSC Installation; Remove Wire 3 & 4 From Terminal N & 3. Connect These Wires To FSC Terminal 1 & 3. Install Wire Harness 1 & 2 Supplied With Kit As Per Drawing. Connect NTC Sensor (S) To FSC Terminal 23 & 24
  3. Set The FSC Trimmer To Complete The Installation

## 9. EVI CoreSense™ control kits and LED Indications

### EVI CoreSense control kits

The EVI CoreSense control kit of Dual Temperature H-Series unit is intended to control vapor injection, maintain a safe discharge temperature, and provide intelligent diagnosis and protection.

The kit includes a printed circuit board (PCB), an electronic expansion valve (EXV), and three sensors, as well as containing a transformer and an EXV filter.

In vapor injection application, the valve is driven by sensors mounted near the heat exchanger and attempts to maintain the vapor outlet sensor 5K higher than the vapor inlet. The system will switch to discharge line temperature control if vapor injection is insufficient to maintain a safe discharge temperature. If the discharge temperature becomes dangerously high, the system will stop the compressor, turn on an LED alarm, and trigger a voltage free alarm relay contact. The compressor can auto-reset, but not lockout.

### Printed circuit board

Wear a ground strap when working with the PCB to avoid the risk of damage from static discharges.

General PCB layout, input and output ports are shown in the image below, the ports to EXV, DLT, as well as the vapor in and vapor out sensors are done with Poka-yoke connector design. Connect sensors, EXV, and system wiring as shown in wiring diagram.

The PCB is supplied power through a transformer with a power input of 50/60 Hz, 220VAC, and an output of 12VAC to the PCB board.

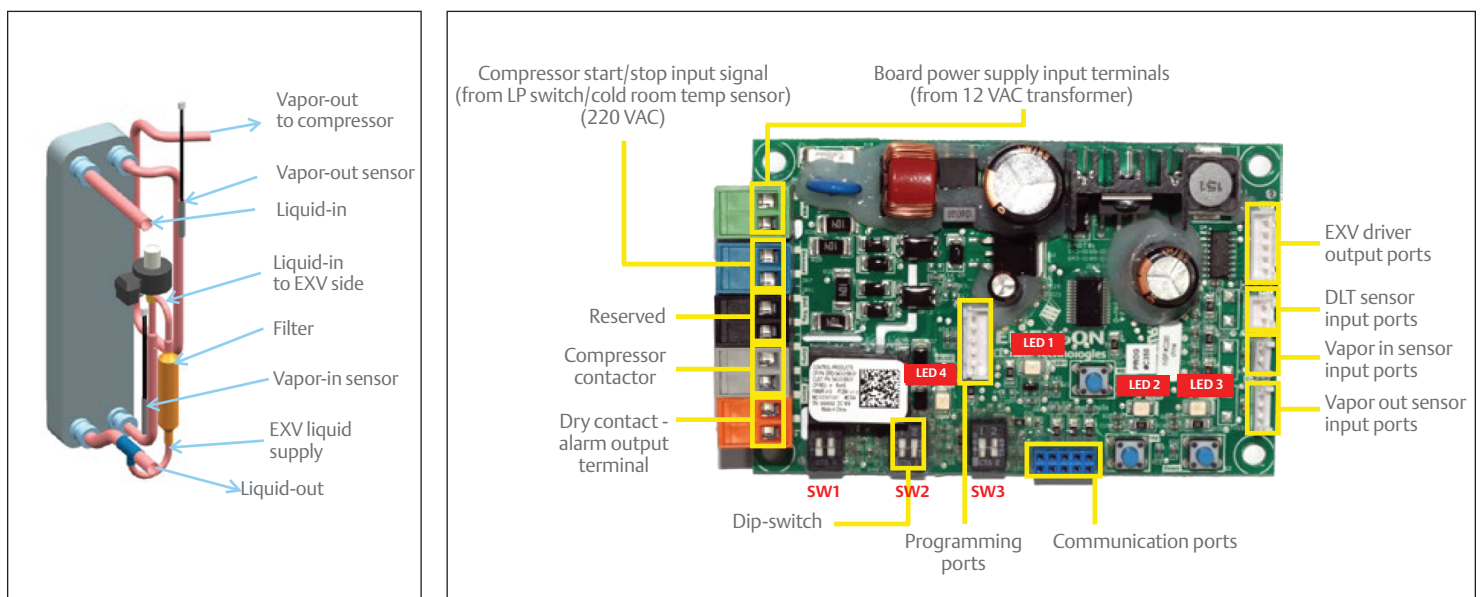

## DIP Switch Setting

SW1	Bit 1	Bit 2	DLT Control Point	Default
	OFF	OFF	95 deg C	
	OFF	ON	100 deg C	
	ON	OFF	105 deg C	
	ON	ON	110 deg C	

COMPRESSOR SHUTDOWNS AT 125 DEG C DLT

SW2	Bit 1	Reset Mode	Default
	ON	Lockout After 5 trips in 1 hr	
	OFF	Auto Reset	
	Bit2	Vapour Injection Superheat	
	ON	10 deg K	
	OFF	5 deg K	

SW3	Bit 1	Compressor Time Delay	Default
	ON	2 minutes	
	OFF	0	
	Bit 2	Injection Mode	
	ON	Vapour Injection	
	OFF	Liquid Injection	

## LED Indications

LED1 (yellow-green)

LED1 will light up during initialization after power on, after that, blinking lights will indicate the sensor status.

LED Number	Color	LED Flash Code	Compressor / Sensor Status
LED1	Yellow - Green	1	Compressor waiting to start
		2	DLT overheat protection
		3	DLT sensor failure
		4	Vapor-in sensor failure
		5	Vapor-out sensor failure

LED Number	Color	LED Flash Code	EXV Status
LED2	Yellow - Green	1	EXV Opening
		Constant ON	EXV Fully Open

LED Number	Color	LED Flash Code	EXV Status
LED3	Yellow - Green	1	EXV Closing
		Constant ON	EXV Fully Closed

LED Number	Color	LED Flash Code	Compressor / Sensor Status
LED4	Red	Constant On	DLT overheat protection
			DLT sensor failure
			Vapor-in sensor failure
			Vapor-out sensor failure

## 10. Installation, system processing and commissioning

Utmost care must be taken while handling the H-Series condensing unit. Please go through the contents below to ensure proper handling.

### a. Inspection

Inspect the condensing unit and any accessories shipped with them for damages or shortages before and during unloading. All items on bill of lading should be accounted for prior to signing the shipping receipt. Note any shortages or damage on delivery receipt (specify the extent and type of damage found). Unit should be inspected carefully for concealed damage.

Notify Emerson sales/application personnel of the damage immediately.

Request an immediate joint inspection and do not repair the unit until inspected by Emerson's representative.

The system is shipped with a holding charge of dry nitrogen. Check to see that pressure is still in the unit upon receipt. Report lack of pressure immediately to the Emerson's application/sales representative.

### b. Location and Fixing

The unit should always be installed in a location that ensures clean air flow.

It is recommended that a clearance of 300 mm from the wall (or the next unit) be maintained from the unit's left and rear panels whereas a clearance of 500 mm must be maintained from the unit's right, top and front panels (seen facing the front of the unit).

Both service access and airflow have been considered in making these recommendations.

Where multiple units are to be installed in the same location, the contractor needs to consider each individual case carefully.

There can be many variations of unit quantities and available space and it is not the intention of this manual to go over these. Ideally, the unit should be mounted on a solid concrete slab with anti-vibration pads between unit feet and concrete.

However, the H-Series condensing unit has also been designed for wall mounting on suitable brackets. Wall mounting brackets are not included. Another factor to consider in finding a good installation site is the direction of the prevailing wind. For example if the air leaving the condenser faces the prevailing wind, the air flow through the condenser can be impeded, causing high condensing temperatures ultimately resulting in reducing unit life. A baffle is a remedy for this situation.

### c. Refrigeration Piping Installation

All interconnecting pipes should be of refrigeration grade, clean, dehydrated and must remain capped at both ends until installation. Even during installation, if the system is left for any reasonable period (say two hours), pipes should be re-capped to prevent moisture and contaminants from entering the system.

Do not assume that the service connection sizes on the unit (at the service valves) are the correct size to run your interconnecting refrigeration pipes. The service valve sizes have been selected for convenience of installation and in some cases (larger units) these may be considered too small. However, for the very short pipe run within our units, these service connection sizes are adequate.

The pipe should be sized to ensure optimum performance and proper oil return. The sizing must also consider the full capacity range through which this particular unit will need to operate.

Pipe runs should be kept as short as possible, using the minimum number of directional changes. Use large radius bends and avoid trapping of oil and refrigerant. This is particularly important for the suction line. The suction line should ideally slope gently towards the unit. Recommendation slope is  $1/200 \sim 1/250$ . P traps, double risers and reduced pipe diameters may be required for suction lines where long vertical risers cannot be avoided. All pipes should be adequately supported to prevent sagging which can create oil traps.

The recommended pipe clamp support distance is shown in the table.

Tube Dia	Max distance between 2 clamp support
1/2 inch	1.2 M
5/8 inch	1.5 M
7/8 inch	1.8M
1 1/8 inch	2.1M
1-5/8	2.3

### d. Refrigerant line insulation

- Insulate suction lines from the evaporators to the condensing unit with minimum 1" thickness closed-cell type insulation on low temperature circuits.
- Liquid lines of Dual temperature systems to be insulated with minimum of  $3/4$ " insulation.
- Long liquid lines run in areas exposed to high temperatures should be fully insulated with minimum  $1/2$ " insulation.
- Suction and liquid lines should never be taped or soldered together.

### e. Electrical

- All electrical work must be done in accordance with the National Electrical Code and existing local codes.
- Power supply must be the same as specified on the unit's name plate.
- Voltage fluctuations in excess of 10 percent must be corrected.
- Before starting the unit, ensure that all protective devices are in place and that all wiring is secure.

### f. Brazing Recommendation

Maintain a flow of oxygen-free nitrogen through the system at a very low pressure during brazing. Nitrogen displaces the air and prevents the formation of copper oxides in the system. If copper oxidization is allowed to form, the copper oxide material can later be swept through the system and block screens such as those protecting capillary tubes, thermal expansion valves, and accumulator oil return holes. This minimizes any entry of contaminants and moisture.

- Remove the liquid line connection cap.
- Then remove the suction connection cap.
- Open both valves midway.
- Care should be taken to avoid the holding charge from releasing too quickly.
- Be sure tube fitting inner diameter and tube outer diameter are clean prior to assembly.
- Since both tubes are extended from the condensing unit housing, we recommend insulating the housing by using a wet cloth on the copper tubing.
- Recommended brazing materials: a copper / phosphorous or copper / phosphorous / silver alloy rod should be used for joining copper to copper whereas to join dissimilar or ferric metals, use a silver alloy rod, either flux coated or with a separate.
- Use a double tip torch.

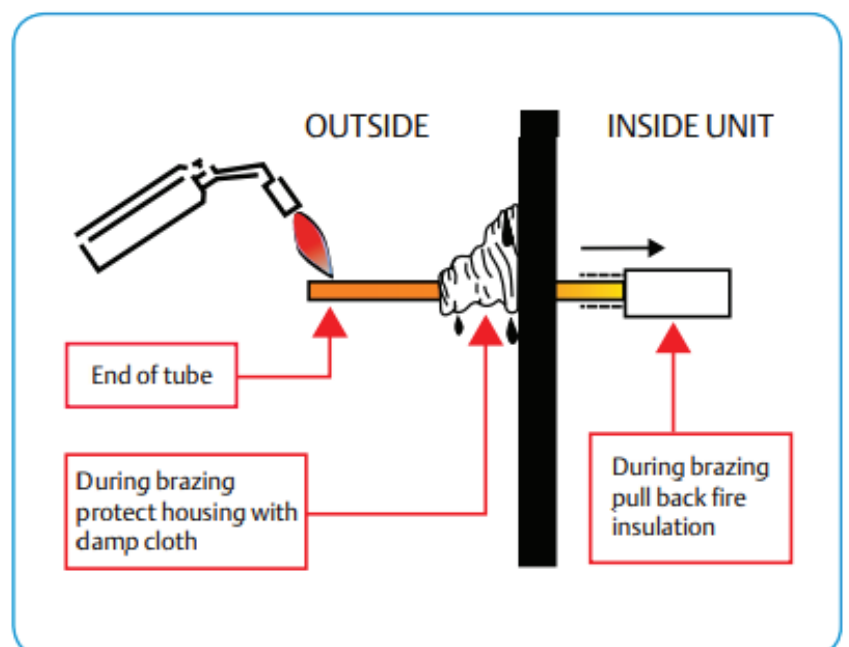



## g. Start-up & Operation

### **Initial pressure test (by vacuum and nitrogen) - Step-by-step:**

- Use a 4-port gauge manifold with 3/8" hose and connections to the vacuum pump. The vacuum gauge does not have to be connected for this part of the process.
- Connect the gauges to service ports provided on receiver valve and suction tube. In order to remove any non-condensable that may have entered the system during installation, follow these steps:
- Start the vacuum pump. The evaporator fan should be running and the compressor crankcase heater is energized at this point. This will involve powering up the unit so it is important to disconnect the live feed wire to the compressor contactor (so the compressor cannot run and the crankcase heater can be energized).
- Open both valves on the manifold and then open the main vacuum valve on the pump. Run the system until the vacuum level of -0.85 bar (as read on manifold gauge) is achieved.
- Shut off the main vacuum pump valve. Check for vacuum rise using the manifold compound gauge. A rise would indicate a large leak.
- If vacuum holds for 10 minutes, break vacuum with Nitrogen. Check the name plate of the unit / compressor for allowable leak test pressure. Ensure that pressure regulators are installed on the Nitrogen cylinders. Check for leaks and repair leakage.

### **Leak Check**

The success of all the subsequent commissioning depends on a leak free system, free of contaminants, free of oxides, free of non-condensables, that has been evacuated to a low vacuum and charged with the prescribed refrigerant.

Leak test is particularly important for field-connected systems. Typically, field systems lose as much as 20%–30% of their refrigeration charge annually. This is not only an unnecessary expense but also damages the environment. Compressor oil can be lost at the same time as refrigerant and eventually lead to compressor failure. (Time spent on leak test will eventually reduce the time spent on the evacuation process).

Ensure that all service valves are open during the leak test process. It is important to recheck all joints within the unit as well as the external joints.

- The unit is shipped with a holding charge of dry nitrogen and should be leak free.
- Ensure that the test pressure do not exceed the system design pressures.
- Do not expose system pressure control LP to test pressures above the design pressure. This can damage the pressure controls.
- Using an approved, calibrated electronic gas leak detector, leak test the entire system paying attention to all joints (you might have to charge small quantity of refrigerant before charging the Nitrogen to enable this procedure).
- Periodically check functionality of the electronic leak detector during this process.
- To further check system integrity, spray a soapy water solution over joins then visually inspect for bubbles.
- Leave the system under pressure for a designated period (24 Hours).
- Check and record the ambient temperatures and the system pressure with calibrated approved instruments. This process is to be carried out every 8-12 hours during the pressure testing process.
- If the test pressures cannot be maintained, repeat the leak testing process employing the isolation of sections of the system to determine the source of leaks. Repair the leak and repeat the leak testing process until system can be signed off as leak free and approved by authorized personnel.
- Record findings and confirm pressure testing process completion.

### **Evacuation**

- After the system is leak checked, connect approved dual stage vacuum pump sized to application with preferably fresh oil to evacuate the system.
- Ensure all inline system shut-off valves and solenoid valves are fully open.
- Evacuate the system to 300 microns.
- A triple evacuation is recommended in case of using analog gauges as we might not know the exact vacuum level being achieved

### **Charging and commissioning**

Reminder:

- The scroll compressor design requires system charging with liquid refrigerant into the liquid line.
- Do not vapor charge the H-Series Scroll unit. After ensuring all valves are opened and system is evacuated properly, only then start the refrigerant charging process. Also ensure that LP cutout is not by-passed during the charging process.

### Step-by-step:

- Ensure that there is no power supply to the H-Series unit. The Liquid Line solenoid needs to be kept open for the charging process and this may require a temporary power feed to it.
- Connect the refrigerant cylinder to main service hose and purge line at the manifold end.
- Ensure correct orientation of the refrigerant cylinder. Follow cylinder labeling/instructions so that liquid refrigerant can be charged into the system. This will be charged through the high-pressure side of the manifold and H-Series unit liquid service valve. Ensure that at least 70-80% of the required refrigerant charging is done by this method.
- The compressor can then be started, and the unit continued to be charged (with the controlled liquid refrigerant through the suction service valve). The quantity of charge should always be measured. See note.
- The system needs to be operated down to its design evaporating temperature before you can be sure the charge is correct. It is at this point that the normal refrigeration operational checks can be carried out - such as checking the liquid line sight glass for bubbles and the operating pressures.

Refrigerant charging is regarded full/complete when the operating temperature of the system has been stable for some time and the liquid line sight glass is clear.

## h. Maintenance

### Condenser Fins

Condenser fins become dirty over time as ambient air is induced to the condenser. Dirty coil surfaces result in high condensing temperatures and poor unit performance. Regular cleaning is recommended with frequency depending on the installation and the surrounding environment. As a general guide, it is advisable to do this at least once every two months.

Fins should be cleaned with liquid detergent diluted with clean water. Before washing, a light brush downward (in the direction of the fins) should be done to remove heavy deposits.

### Electrical Connections

Check tightness of electrical connections occasionally.

### Routine Leak Test

All joints should be checked for leaks during site visits. All joints should be leak tested once a year. Condenser Fan(s) and Motor(s), an annual inspection of these items is recommended. Fastenings may loosen, bearings may wear, and fans may require cleaning of solid deposits which can cause imbalance.

 **TURN OFF OR DISCONNECT THE ELECTRICAL POWER SOURCE BEFORE CLEANING THE CONDENSER COIL OR DOING MAINTENANCE.**

# System Start-Up and Operational Check Sheet

## Client Details

Facility/Customer Name :	
Address :	
Contact Details :	
Installer :	
Installation Date :	

## Condensing Unit Info

CDU Model :	
Serial Number :	
CDU Location :	
Indoor Unit Make/Model :	

## System Details

Room/Case ID :	
Pipe Length (approx.) :	
OAT @ Start-Up/Check :	
PSI Leak Test :	<b>PSIG</b>
Duration :	<b>Hours</b>
System is Leak Tight :	<b>Y / N</b>
Triple Evacuation :	<b>Y / N</b>
Micron Gauge Reading :	<b>microns</b>
Total Evacuation :	<b>PSIG @ # of Hrs</b>
Refrigerant :	
Total Charge :	<b>Kg.</b>
Sight Glass Clear :	<b>Y / N</b>
Evap Fans Running :	<b>Y / N</b>
Liquid Line Insulation :	<b>Y / N</b>
Sound and Vibration	

## System Operation

COMP Voltage :	<b>V</b>
COMP Current :	<b>A</b>
Suction Pressure :	<b>PSIG/Bar</b>
Liquid Line Pressure :	<b>PSIG/Bar</b>
COMP Suction Temp :	<b>°C</b>
COMP Disch Temp :	<b>°C</b>
Liquid Line Temp :	<b>°C</b>
Compressor SH :	<b>K</b>
Subcooling :	<b>K</b>
Adjustable LP Setpoint :	<b>PSIG</b>
Design/Operating Temp:	<b>°C</b>
Actual Room/Case Temp :	<b>°C</b>
Condenser Fins :	

## Comments

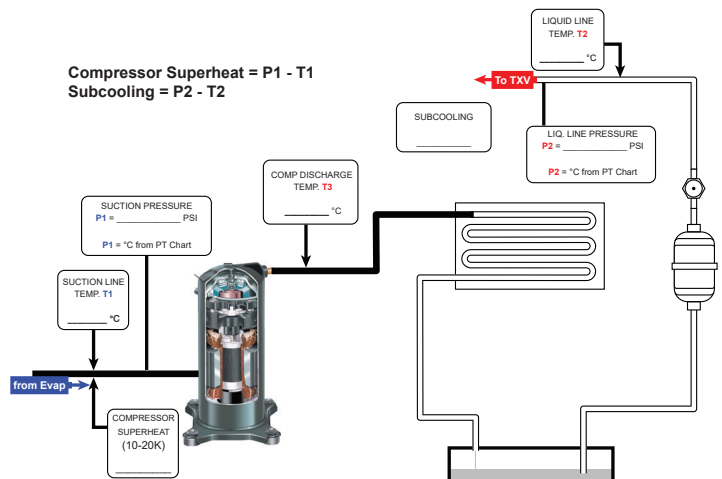
Prepared by: \_\_\_\_\_

Date: \_\_\_\_\_

## Disclaimer

Technical data given was correct at the time of printing. Products, specifications and data in this literature are subject to change without prior notice. Updates will be done periodically. Should you need clarification of a specific data, value or information, kindly contact Emerson representative.

## Contact list

### United Arab Emirates

Jebel Ali Free Zone  
P.O. Box 26382, Dubai  
United Arab Emirates  
Toll Free: 8000 441 3428  
Tel: +971 4 8118100  
Fax: +971 4 8865465

### Saudi Arabia

P.O. Box 34332 - 3620  
2nd Industrial City, 67 St.  
Dammam, Saudi Arabia  
Toll Free: 8008 443 426  
Tel: +966 3 8147560  
Fax: +966 3 8147570

### South Africa

11 Quark Crescent  
Linbro Business Park  
Sandton 2065, South Africa  
Toll Free: 0800 980 3711  
Tel: +27 11 451 3700  
Fax: +27 11 451 3800

### Egypt

P.O.Box 11799  
11 Mustafa Refaat Street  
Sheraton, Heliopolis  
Cairo, Egypt  
Tel: +20 2 226 5854



EmersonMEA



EmersonMiddleEastAfrica

EmersonClimateMEA.com



**EMERSON**™