

Copeland scroll compressors for heat pump applications

YH23K1E to YH38K1E

Table of contents

About these guidelines.....	1
1 Safety instructions.....	1
1.1 Icon explanation.....	1
1.2 Safety statements.....	2
1.3 General instructions.....	2
2 Product description.....	3
2.1 Compressor range.....	3
2.2 Nomenclature.....	3
2.3 BOM variations.....	3
2.4 Application range.....	4
2.4.1 Qualified refrigerants and oil.....	4
2.4.2 Application limits.....	4
2.4.3 PED category and maximum allowable pressure PS.....	5
2.5 Dimensions.....	6
2.5.1 Compressors YH*K1E with BOM GCZ & JCE (single-compressor configuration)	6
2.5.2 Compressors YH*K1E with BOM GCY, JCD & GCW (tandem/trio-compressor configuration).....	7
3 Installation.....	8
3.1 Compressor handling.....	8
3.1.1 Transport and storage.....	8
3.1.2 Positioning and securing.....	8
3.1.3 Installation location.....	8
3.2 Mounting parts.....	8
3.3 Brazing procedure.....	9
3.3.1 General brazing procedure.....	9
3.3.2 Brazing procedure for YH*K1E compressors in parallel applications.....	10
3.4 Pressure safety controls.....	10
3.4.1 High-pressure protection.....	10
3.4.2 Low-pressure protection.....	10
3.5 System protection for operation below atmospheric pressure.....	11
3.6 Crankcase heater.....	11
3.7 Soft starters.....	12
3.8 Discharge gas temperature protection.....	13
3.8.1 Excessive discharge gas temperatures.....	13

3.8.2	Discharge temperature sensor NTC.....	13
3.9	Internal pressure relief valve	14
3.10	Discharge check valve	14
3.11	Filter screens	14
3.12	Mufflers.....	14
3.13	Sound shell.....	14
3.14	Insulation material.....	14
3.15	Reversing valves	15
3.16	Sound and vibration	15
3.17	Compressor oil return, oil balancing, refrigerant floodback and oil dilution tests.	16
3.18	Suction line accumulator	17
4	Electrical connection	18
4.1	General recommendations.....	18
4.2	Electrical installation	18
4.3	Terminal box.....	19
4.3.1	IP54 terminal box (BOM GCZ, GCY & GCW)	20
4.3.2	IP65 metal terminal box (BOM JCE & JCD)	20
4.4	Motor insulation	21
4.5	Motor protection.....	21
4.6	High-potential testing	22
5	Start-up & operation	23
5.1	Strength-pressure test	23
5.1.1	Compressor strength-pressure test.....	23
5.1.2	System strength-pressure test	23
5.2	Compressor tightness test	24
5.3	System evacuation.....	24
5.4	Preliminary checks – Pre-starting.....	24
5.5	Charging procedure	25
5.6	Run-in time	25
5.7	Initial start-up	25
5.8	Rotation direction.....	25
5.9	Start-up and shut-off sound.....	26
5.10	Deep vacuum operation.....	26
5.11	Pumpdown cycle.....	26
5.12	Shell temperature	26
5.13	Minimum run time	26
5.14	Supply frequency and voltage.....	27
5.15	Oil level.....	27

6	Maintenance & repair	28
6.1	Qualification of workers.....	28
6.2	Preparation and work procedure	28
6.3	Disassembling system components	29
6.4	Exchanging the refrigerant.....	29
6.5	Replacing a compressor	30
6.5.1	Compressor replacement.....	30
6.5.2	Start-up of a new or replacement compressor	30
6.5.3	Compressor return procedure	30
6.6	Lubrication and oil removal	31
6.7	Oil additives	32
7	Dismantling & disposal	33
8	References.....	33

About these guidelines

The purpose of these guidelines is to provide guidance in the application of Copeland scroll compressors in users' systems. They are intended to answer the questions raised while designing, assembling and operating a system with these products.

Besides the support they provide, the instructions listed herein are also critical for the proper and safe functioning of the compressors. The performance and reliability of the product may be impacted if it is not used according to these guidelines or is misused.

These application guidelines cover stationary applications only. For mobile applications, please contact the Application Engineering department at Copeland as other considerations may apply.

1 Safety instructions

Copeland scroll compressors are manufactured according to the latest relevant European, UK and US safety standards. Particular emphasis has been placed on the user's safety.

YH*K1E compressors are intended for installation in systems in accordance with the following directives and regulations:

Machinery Directive MD 2006/42/EC	Supply of Machinery (Safety) Regulations 2008
Pressure Equipment Directive PED 2014/68/EU	Pressure Equipment (Safety) Regulations 2016
Low Voltage Directive LVD 2014/35/EU	Electrical Equipment (Safety) Regulations 2016

They may be put to service only if they have been installed in systems according to instructions and conform to the corresponding provisions of legislation. For relevant standards please refer to the Manufacturer's Declaration, available at www.copeland.com/en-gb.









NOTE: Only dedicated compressors are allowed to be used with flammable refrigerants. Copeland marks all compressors that are qualified for flammable refrigerants with a sticker indicating the usage of such refrigerants. Systems using flammable refrigerants must be executed correctly while observing safety rules, as specified in corresponding safety standards such as, but not limited to EN 378. They must comply with any and all applicable legislation and regulations. Ensuring compliance remains the user's responsibility.

The Material Safety Datasheet (MSDS) of each individual refrigerant shall be considered – please check the document provided by the gas supplier.

These instructions shall be retained throughout the lifetime of the compressor.

You are strongly advised to follow these safety instructions.

1.1 Icon explanation

 WARNING This icon indicates instructions to avoid personal injury and material damage.	 Fire hazard This icon indicates a risk of flammable atmosphere.
 High voltage This icon indicates operations with a danger of electric shock.	 CAUTION This icon indicates instructions to avoid property damage and possible personal injury.
 Danger of burning or frostbite This icon indicates operations with a danger of burning or frostbite.	 IMPORTANT This icon indicates instructions to avoid malfunction of the compressor.
 Explosion hazard This icon indicates operations with a danger of explosion.	NOTE This word indicates a recommendation for easier operation.
 Danger of explosive atmosphere This icon indicates a risk of explosive atmosphere.	

1.2 Safety statements

- Refrigerant compressors must be employed only for their intended use. The system has to be labelled according to the applicable standards and legislation.
- Only qualified and authorized RACHP (refrigeration, air conditioning and heat pump) personnel are permitted to install, commission and maintain this equipment.
- Electrical connections must be made by qualified electrical personnel.
- All valid standards for connecting electrical and refrigeration equipment must be observed.
- The national legislation and regulations regarding personnel protection must be observed.

NOTE: For systems using A1 refrigerants (R407C and R134a) the flammable refrigerant sticker is not of application and should be removed from the compressor.

Additional requirements and statements for A2L-refrigerant compressors/systems:

- Only competent personnel (as specified in EN 13313) qualified for flammable refrigerant handling are permitted to commission, initiate and maintain a compressor/refrigeration system using flammable refrigerant; non-trained personnel, including the user, are not allowed to do so and must call on an expert.
- When planning and building systems with such refrigerants, a risk assessment and corresponding precautions for risk mitigation must be taken by the system designer. Special attention must be paid to flammability when dealing with A2L refrigerants.
- The maximum refrigerant charge is specified in standards such as, but not limited to EN 378 and EN 60335-2-40. The system designer shall implement all safety measures defined by the applicable standards and the maximum refrigerant charge shall not be exceeded.
- If a flammable atmosphere is detected, immediately take all necessary precautions to mitigate the risk as determined in the risk assessment.



Use personal safety equipment. Safety goggles, gloves, protective clothing, safety boots and hard hats should be worn where necessary.

1.3 General instructions



WARNING

Pressurized system! Serious personal injuries and/or system breakdown!

Accidental system start before complete set-up must be avoided. Never leave the system unattended without locking it out electrically when it is under vacuum and has no refrigerant charge, when it has a holding charge of nitrogen, or when the compressor service valves are closed.



WARNING

System breakdown! Personal injuries! Only approved refrigerants and refrigeration oils must be used.



WARNING

High shell temperature! Burning! Do not touch the compressor until it has cooled down. Ensure that other materials in the area of the compressor do not come into contact with it. Lock and mark accessible sections.



CAUTION

Overheating! Bearing damage! Do not operate compressor without refrigerant charge or without it being connected to the system.



CAUTION

Contact with refrigerant oil! Material damage! Polyolester (POE) lubricant must be handled carefully and the proper protective equipment (gloves, eye protection, etc.) must be used at all times. Refrigerant oil must not come into contact with any surface or material that it might damage, including, without limitation, certain polymers, eg, PVC/CPVC and polycarbonate.



IMPORTANT

Transit damage! Compressor malfunction! Use original packaging. Avoid collisions and tilting.

2 Product description

2.1 Compressor range

These application guidelines cover Copeland scroll compressor models YH*K1E for heat pump applications with R454C, R407C and R134a refrigerants.

Compressor	Heating capacity* (kW)			Displacement (m ³ /h)	Motor
	R454C	R407C	R134a		
YH23K1E	22.0	24.4	16.2	29.2	TFDN
YH28K1E	26.6	28.7	19.2	35.4	TFDN
YH33K1E	32.5	34.5	23.2	42.4	TFDN
YH38K1E	36.5	39.4	26.5	48.3	TFDN

* Refrigerant dew temperature, evaporating temperature: -7 °C; condensing temperature: 50 °C; suction gas superheat: 5 K; liquid sub-cooling: 4 K; frequency: 50 Hz

Table 1: YH*K1E model overview

2.2 Nomenclature

The model designation contains the following technical information about the compressors:

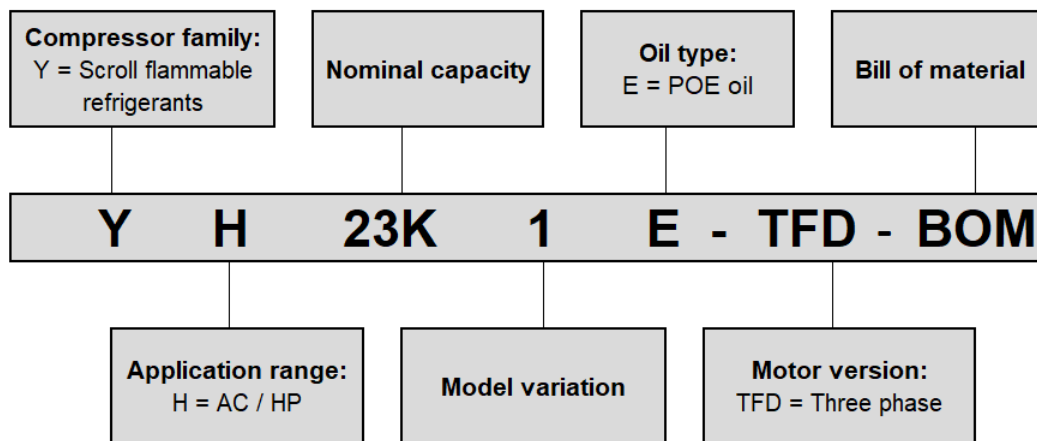

Figure 1: Nomenclature

2.3 BOM variations

The BOM (bill of material) letters at the end of the compressor designation indicate the different compressor layouts and details. YH*K1E compressors are available in the following BOM versions:

BOM	Suction & discharge connections	T Box	Mounting parts	Features
GCZ	Brazing stub tubes	IP54	Without	Single use
JCE		IP65	Without	
GCY		IP54	Without	Tandem/trio use with brazing stub tube for gas and oil equalization
JCD		IP65	Without	
GCW		IP54	Without	Tandem use with brazing stub tube for gas and oil equalization line & extra connection for gas equalization line (GEL for variable speed tandemization)

Table 2: BOM variations

Please refer to the Copeland price list for more details.

2.4 Application range

2.4.1 Qualified refrigerants and oil

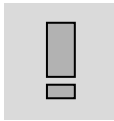

IMPORTANT

Some refrigerant blends have a significant temperature glide. It is essential that the glide of the refrigerant blends be carefully considered when adjusting pressure and superheat controls.

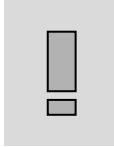

IMPORTANT

Refrigerant blends with low GWP containing HFO's have a low chemical stability in presence of air or humidity. The same levels of cleanliness, dryness and evacuation of the refrigerant circuit are required as in HFC & POE applications, including the use of filter-dryers.

Compressors	YH*K1E
Qualified refrigerants	R454C, R407C & R134a
Qualified oil (factory charged)	Emkarate RL32 3MAF
Servicing oil	Emkarate RL32 3MAF

Table 3: Qualified refrigerants and oil

Oil recharge values can be taken from the compressor nameplate or from Copeland Select software available at www.copeland.com/en-gb/tools-resources.

NOTE: R454C is classified as A2L (mildly flammable) refrigerant.

2.4.2 Application limits



CAUTION

Inadequate lubrication! Compressor breakdown! Copeland scroll compressors are qualified for operation inside the envelope published by Copeland. The envelope is defined according to Copeland's testing and experience. Operating a compressor outside the envelope might lead to compressor failure which would be the heat pump manufacturer's responsibility.

Low superheat! Liquid floodback and compressor breakdown! The superheat at the compressor suction inlet must always be sufficient to ensure that no refrigerant droplets enter the compressor. For a typical evaporator expansion valve configuration, a minimum stable superheat of at least 5 K is required.

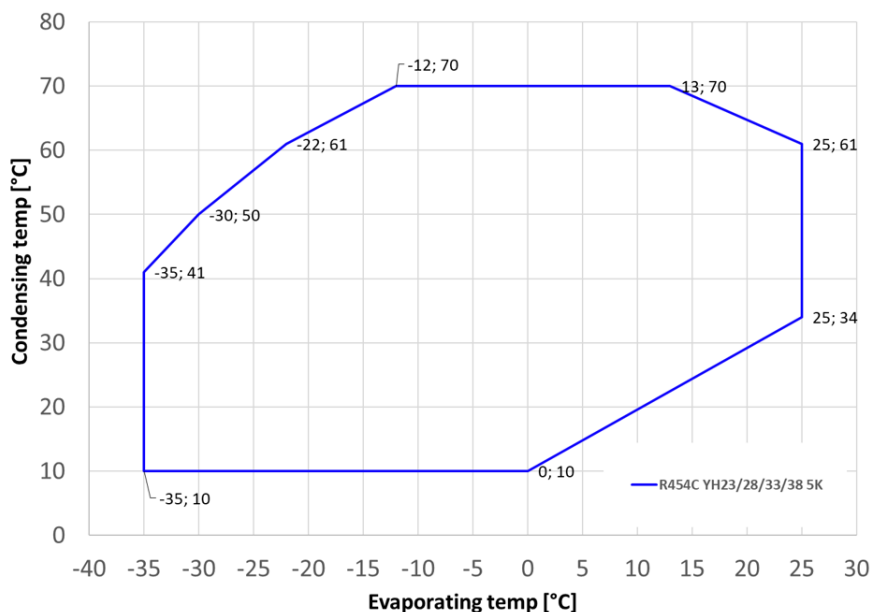

Figure 2: Application envelope for YH*K1E compressors for use with R454C (5 K superheat)

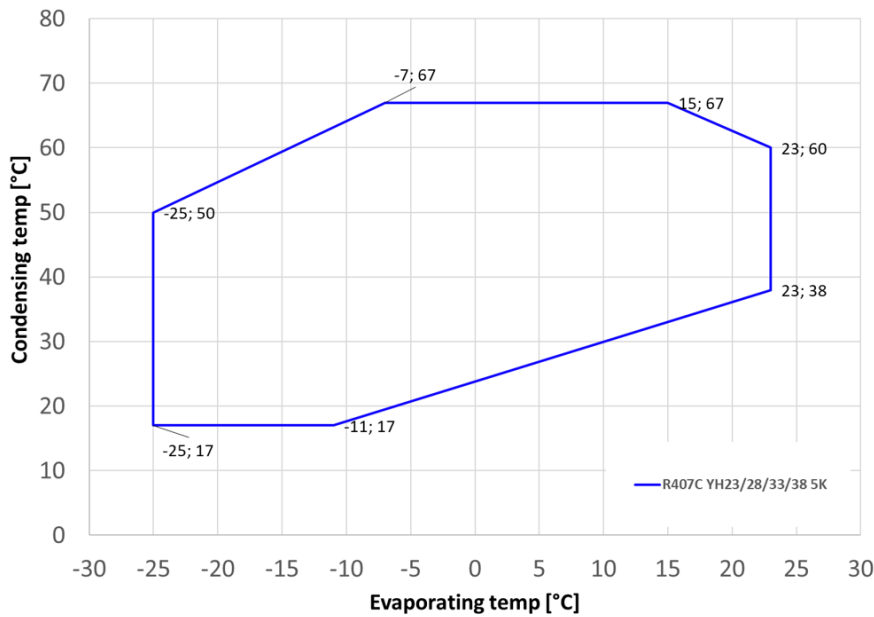

Figure 3: Application envelope for YH*K1E compressors for use with R407C (5 K superheat)

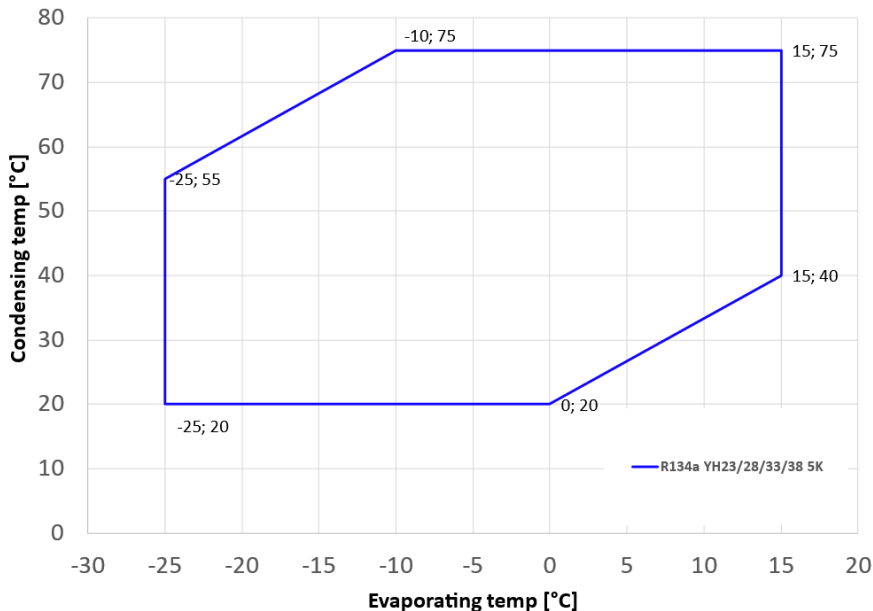

Figure 4: Application envelope for YH*K1E compressors for use with R134a (5 K superheat)

Provided that the discharge temperature does not exceed 135 °C, a superheat between 5 and 10 K is allowed all over the envelope.

For application envelopes and technical data, please refer to Copeland Select software available at www.copeland.com/en-gb/tools-resources.

2.4.3 PED category and maximum allowable pressure PS

The nameplate of the compressor contains information about the maximum allowable pressure PS, the minimum and maximum allowed temperatures TS, the internal free volume and the fluid groups of the refrigerants qualified for the compressor model range. Values are given for both pressure ranges on low- and high-pressure sides.

The PED category is assigned according to the Pressure Equipment Directive PED 2014/68/EU. Requirements apply to the relevant pressure levels in the compressor when the product of "pressure relative to the environment" by "related internal free volume" (PxV) exceeds given limits. When calculating the PED category, the high- and low-pressure sides have to be calculated separately. The highest of the calculation results is considered.

Compressor	PS Low pressure side	PS High pressure side	TS max. Low pressure side	Internal free volume	
				LP side	HP side
YH23K1E	30.4 bar(g)	50 bar(g)	55 °C	12.6 L	1.5 L
YH28K1E	30.4 bar(g)	50 bar(g)	55 °C	12.6 L	1.5 L
YH33K1E	30.4 bar(g)	50 bar(g)	55 °C	12.6 L	1.5 L
YH38K1E	30.4 bar(g)	50 bar(g)	55 °C	12.6 L	1.5 L

Table 4: Maximum allowable pressures, temperatures and internal free volumes

The PED category also depends on the fluid group of the qualified refrigerants, also shown on the nameplate. A distinction is made between refrigerants of fluid group 1 (flammable) and fluid group 2 (non-flammable). The YH*K1E compressors covered in these guidelines can be operated with either A1 (group 2) or A2L (group 1) refrigerants. Consequently, identical compressor models may be subject to different PED categories depending on the refrigerant used.

Compressor range	Refrigerants	Fluid group	PED class
YH23K1E to YH38K1E	R454C	1	III
	R407C	2	III
	R134a	2	III

Table 5: PED class based on refrigerant and fluid group

2.5 Dimensions

2.5.1 Compressors YH*K1E with BOM GCZ & JCE (single-compressor configuration)

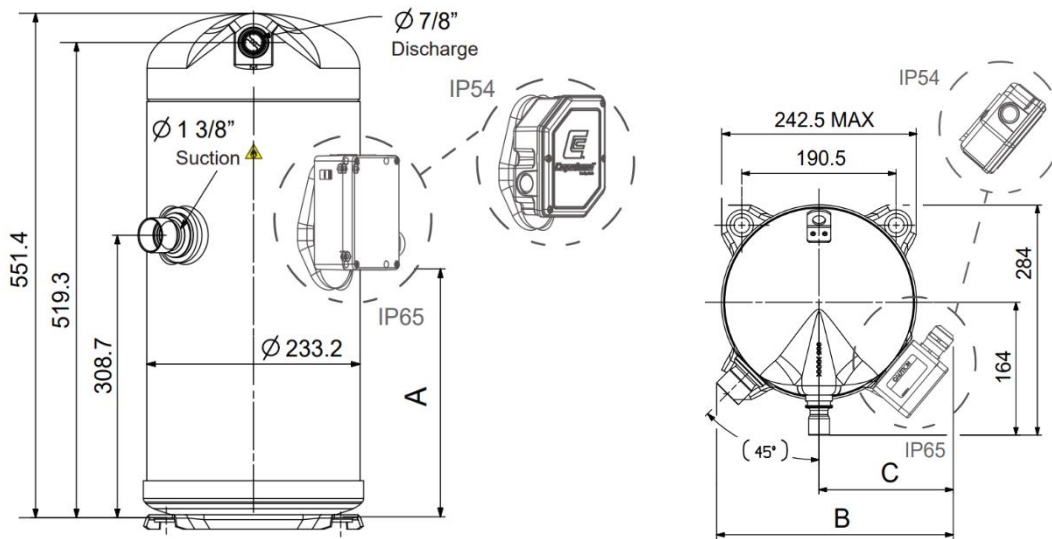

Figure 5: External dimensions - Front & top views

BOM	A (mm)	B (mm)	C (mm)	T Box
GCZ	263.2	289	162.6	IP54
JCE	270.9	292.1	165.8	IP65

Table 6: Dimensions of compressors YH*K1G with BOM GCZ & JCE

2.5.2 Compressors YH*K1E with BOM GCY, JCD & GCW (tandem/trio-compressor configuration)

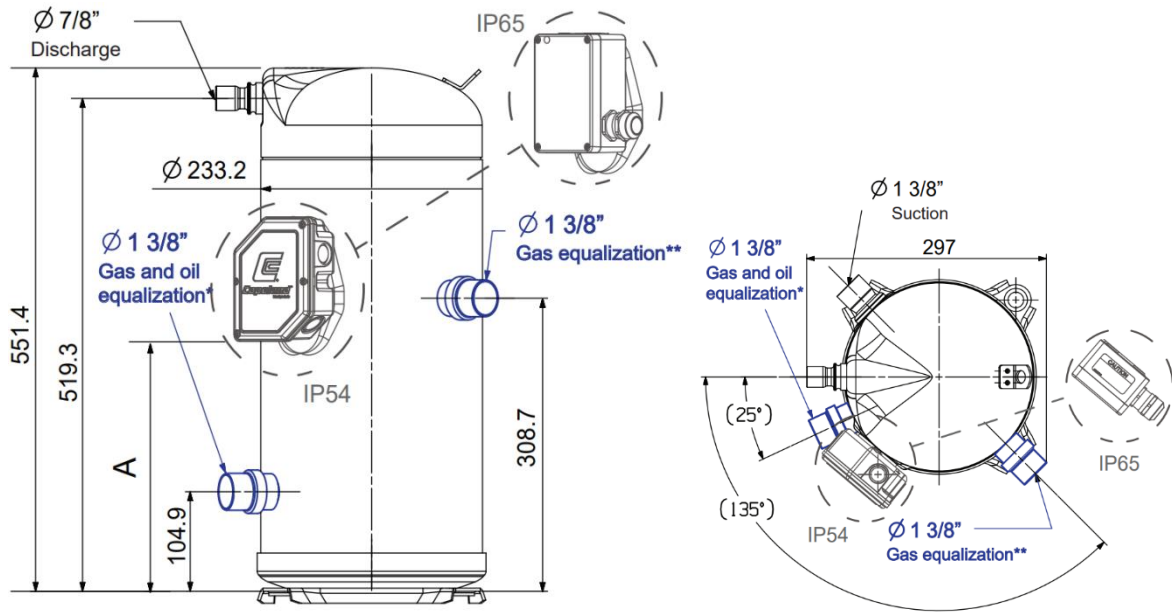

Figure 6: External dimensions – Front & top views

BOM	A (mm)	Gas and oil equalization*	Gas equalization**	T Box
GCY	263.2	Yes	No	IP54
JCD	270.9	Yes	No	IP65
GCW	263.2	Yes	Yes	IP54

Table 7: Dimensions of compressors YH*K1G with BOM GCY, JCD & GCW

NOTE: The connections in blue colour are additional connections for paralleling models (only on BOM version GCY).

3 Installation



WARNING

High pressure! Injury to skin and eyes possible! Be careful when opening connections on a pressurized item.

3.1 Compressor handling

3.1.1 Transport and storage



WARNING

Risk of collapse! Personal injuries! Move compressors only with appropriate handling equipment according to weight. Keep in the upright position. Respect stacking loads according to **Figure 7**. Check the tilting stability and if needed take action to ensure the stability of the stacked loads. Keep the packaging dry at all times.



Respect the maximum number of identical packages which may be stacked on one another, where "n" is the limiting number:

- **Transport: n = 1**
- **Storage: n = 2**

Figure 7: Maximum stacking loads for transport and storage

The compressor tilt angle should not exceed 30° during transport and handling. This will prevent oil from exiting through the suction stub. A tilt angle of maximum 45° is allowed for a very short time. Tilting the compressor more than 45° might affect its lubrication at start-up.

NOTE: The compressor is pre-charged with dry air to avoid any moisture contamination.

3.1.2 Positioning and securing



IMPORTANT

Handling damage! Compressor malfunction! Only use the lifting eyes whenever the compressor requires positioning. Using discharge or suction connections for lifting may cause damage or leaks.

The compressor should be kept vertical during handling.

The discharge connection plug should be removed first before pulling the suction connection plug to allow the dry air pressure inside the compressor to escape. Pulling the plugs in this sequence prevents oil mist from coating the suction tube making brazing difficult. The copper-coated steel suction tube should be cleaned before brazing.

The plugs must be removed as late as possible before brazing so that the air humidity does not affect the oil characteristics.

No object, eg, a swaging tool should be inserted deeper than 51 mm into the suction tube as it might damage internal parts.

3.1.3 Installation location

Ensure the compressors are installed on a solid level base. For single-compressor applications, the compressor tilt angle during operation should not exceed 15° to allow adequate lubrication. For multiple-compressor parallel configurations, the compressors must be positioned completely vertically on a totally horizontal surface or rail.

3.2 Mounting parts

The compressors are designed to be mounted on vibration absorber grommets. The grommets dampen the start-up surge of the compressor and minimise sound and vibration transmission to the compressor base during operation. The metal sleeve inside is a guide designed to hold the grommet in place. It is not designed as a load-bearing member, and application of excessive torque to the bolts can crush the sleeve. Its inner diameter is approximately 8.5 mm to fit, eg, an M8 screw. The mounting torque should be 13 ± 1 Nm. It is critically important that the grommet is not compressed.

If the compressors are mounted in tandem or used in parallel, then metal spacers between compressor and rails are recommended, an M10 screw is applied and the mounting torque should be between 45 and 55 Nm.

See Copeland spare parts catalogue at www.copeland.com/en-gb/tools-resources for references.

3.3 Brazing procedure



WARNING

Air/flamable refrigerant mixture! Creation of a potentially flammable atmosphere! Fire hazard! Remove all refrigerant before opening the system. When working on a refrigerant-filled system, make sure to follow the safety and working instructions given in **Chapter 6 "Maintenance & repair"**.



WARNING

High temperature! Burning! Proceed with caution when brazing system components. Do not touch the compressor until it has cooled down. Ensure that other materials in the area of the compressor do not come into contact with it.



CAUTION

Blockage! Compressor breakdown! Maintain a flow of oxygen-free nitrogen through the system at very low pressure during brazing. Nitrogen displaces the air and prevents the formation of copper oxides in the system. If allowed to form, the copper oxide material can later be swept through the system and block screens such as those protecting capillary tubes, thermal expansion valves, and accumulator oil return orifices.

Contamination or moisture! Bearing failure! Do not remove the connection plugs until the compressor is set into the unit. This minimises any entry of contaminants and moisture.

3.3.1 General brazing procedure

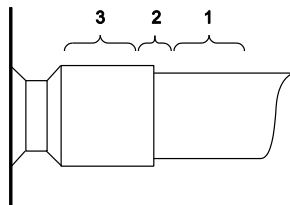

Copeland scroll compressors have copper-plated steel suction and discharge stub tubes. These stub tubes are far more robust and less prone to leaks than copper tubes. Make sure the brazing procedures are carried out in an appropriate manner taking into account the different thermal properties of steel and copper.

Figure 8: Brazing areas

Refer to **Figure 8** and procedure below for the brazing of the stub tube connections of a scroll compressor.

- Flushing oxygen-free nitrogen through the piping during the brazing process is recommended for applications with A1 refrigerants and mandatory for applications with flammable A2L refrigerants.
- The copper-coated steel tubes on scroll compressors can be brazed in approximately the same manner as any copper tube.
- Recommended brazing materials: any Silfos material is recommended, preferably with a minimum of 5 % silver. However, 0 % silver is acceptable.
- Be sure tube fitting inner diameter and tube outer diameter are clean prior to assembly.
- Using a double-tipped torch, apply heat in area 1.
- As the tube approaches brazing temperature, move the torch flame to area 2.
- Heat area 2 until braze temperature is attained, moving the torch up and down and rotating around the tube as necessary to heat the tube evenly. Add braze material to the joint while moving the torch around the joint to flow braze material around the circumference.
- After the braze material flows around the joint, move the torch to heat area 3. This will draw the braze material down into the joint. The time spent heating area 3 should be minimal.
- As with any brazed joint, overheating may be detrimental to the final result.

NOTE: Since the discharge stub contains a check valve, care must be taken not to overheat it to prevent brazing material from flowing into it.

3.3.2 Brazing procedure for YH*K1E compressors in parallel applications



WARNING

Air/flamable refrigerant mixture! Creation of a potentially flammable atmosphere! Fire hazard! Remove all refrigerant before opening the system. When working on a refrigerant-filled system, make sure to follow the safety and working instructions given in **Chapter 6 "Maintenance & repair"**.



WARNING

High oil temperature! Risk of ignition and personal injuries! The high temperature generated during the brazing process can exceed the flash point of the oil and consequently lead to vapour/air mixture ignition. Make sure to always keep the oil temperature below its flash point. Never braise pipes with oil inside.

Only compressor models officially approved by Copeland in the qualified configuration may be used for parallel applications. For YH*K1E compressors in parallel applications with passive oil management, additional precautions shall be taken before brazing the oil and gas equalization ports. The sequence shall be as follows:

First, install the compressors on the base frame and tilt the assembly so that oil will not be lost when opening the cap. The gas and oil equalization line assembly should be ready for brazing at this point. For new compressors, release the protective gas charge: the rubber plug from the discharge port of the compressor has to be removed first, then the rubber plug from the oil port.

Most probably the oil fitting will be coated with some oil. It is mandatory to clean out the oil before brazing. If the inner surface is contaminated with oil the brazing material will not adhere to the surface and the joint will fail, generating leakage. The oil should be carefully wiped out with industrial absorption paper. Industrial solvents on a clean cloth can be used too but only with great care. Note that emery cloth will not remove the oil.

It is possible that the oil cannot be completely cleaned out. In this case additional measures should be taken. For instance, if a connection is coated with flux then the residual oil will be removed when brazing thanks to the applied heat.

NOTE: If an active oil level control is to be used, please refer to the product documentation when brazing the connection adaptor.

3.4 Pressure safety controls

3.4.1 High-pressure protection

Applicable regulations and standards, for example EN 378-2, shall be followed to apply appropriate control and ensure that the pressure never exceeds the maximum limit.

High-pressure protection is required to stop the compressor operating outside the allowable pressure limits. The high-pressure control must be installed correctly, which means that no service valve is allowed between the compressor and the pressure protection.

The high-pressure cut-out setting shall be determined according to the applicable standard, the type of system, the refrigerant and the maximum allowable pressure PS.

3.4.2 Low-pressure protection



CAUTION

Operation outside the application envelope! Compressor breakdown! A low-pressure protection should be fitted in the suction line in order to stop the compressor when it operates outside the envelope limits. Do not bridge or by-pass the low-pressure limiter.

Applicable regulations and standards shall be followed to apply appropriate control and ensure that the pressure is always above the required minimum limit.

Low-pressure protection is required to stop the compressor operating outside the allowable envelope limits. The low-pressure control must be installed correctly into the suction line, which means that no service valve is allowed between the compressor and the pressure protection.

The minimum cut-out setting shall be determined according to the refrigerant and the allowed operation envelope – see Select software at www.copeland.com/en-gb/tools-resources.

3.5 System protection for operation below atmospheric pressure



WARNING

Operation below atmospheric pressure! Fire hazard! During operation below atmospheric pressure, a flammable mixture can form inside the system. Ensure system tightness to prevent any ingress of air.

YH*K1E compressors used in R454C systems can be operated below atmospheric pressure. In that case, special requirements for safety and tightness apply and the following precautions must be observed:

- Check all the critical points on the system and the piping connections; tightness has to be ensured also at very low pressure.
- Minimum absolute working pressure: 0.5 bar.
- The installation of mechanical high-pressure and low-pressure cut-outs is mandatory. For systems provided with a service shut-off valve on the discharge side of the compressor, only a mechanical pressure cut-out shall be used. Electronic pressure limiters, which could cause delayed sensor response, are not allowed.
- The high- and low-pressure cut-outs must be installed correctly on the discharge and suction lines, which means that no service valve is allowed between the compressor and the pressure protection (refer to EN 378 or ISO 5149).
- A discharge temperature control is mandatory to stop the compressor when the maximum discharge temperature is exceeded – see **section 3.8 "Copeland scroll fixed-speed compressors"** can generally be operated with soft starters. Soft starter versions and sizes should be selected according to the soft starter manufacturer's recommendations, taking into consideration the compressor amps. Normally, the ramp-up time should not exceed 1 second.

Due to the inherent design of the Copeland scroll, the internal compression components start unloaded, even if system pressures are not balanced. Since the compressor internal pressures are balanced at start-up, low voltage starting characteristics are excellent, and starting components are normally not required.

However, for extreme electrical conditions such as weak power supplies, single-phase soft starters can be supplied on request by Copeland, while three-phase soft starters are available on the market.

- Discharge gas temperature protection".
- Additional warning notices shall be affixed to any system equipped with shut-off valves. The warnings must contain instructions to open the shut-off valves completely after each repair or maintenance work. The compressors may only be energized when the safety measures (high- and low-pressure cut-outs and discharge temperature cut-out) have been checked and verified to be operational.

NOTE: All of the above points must be fulfilled. If only one of them is not complied with, the compressor shall not be operated below atmospheric pressure.

3.6 Crankcase heater



WARNING

Ignition source in a potentially flammable atmosphere! Fire hazard! The crankcase heater is not an ignition source during normal operation in A2L-refrigerant systems but could become one if not installed properly according to installation instructions. Ensure correct electrical and mechanical installation.



CAUTION

High temperature! Overheating and burnout! Compressor damage! Follow assembly instructions. If installed incorrectly, the heater can reach temperatures over 150 °C. In this case, turn off the heater and do not touch the surface. Keep wiring cables away from the heating elements.

Never apply power to the crankcase heater in free air, before the crankcase heater is installed on the compressor or when it is not in complete contact with the compressor shell.

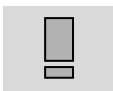

IMPORTANT

Oil dilution! Bearing malfunction! Turn the crankcase heater on 12 hours before starting the compressor.

A crankcase heater is used to prevent refrigerant from migrating into the shell during standstill periods. The installation of a crankcase heater is required when the system charge exceeds the charge limits indicated in **Table 8**. This requirement is independent from system type and configuration.

Compressor model	Refrigerant	Refrigerant charge limit	Crankcase heater	
			Position	Height
YH*K1E	R454C	6.9 kg		53 to 59 mm
	R407C	7.5 kg		
	R134a	8.0 kg		

Table 8: Refrigerant charge limits for single-compressor application & crankcase heater position

The initial start-up in the field is a very critical period for any compressor because all load-bearing surfaces are new and require a short break-in period to carry high loads under adverse conditions. **The crankcase heater must be turned on a minimum of 12 hours prior to starting the compressor.** This will prevent oil dilution and bearing stress on initial start-up. **The crankcase heater must remain energized during compressor off cycles.** **Caution:** Crankcase heaters must be properly grounded!

NOTE: Please refer to the Copeland spare parts catalogue available at www.copeland.com/en-gb/tools-resources to select the appropriate crankcase heater model.

For installation, the manufacturer/installer shall follow the recommendations mentioned below.

Assembly instructions

- Choose the appropriate model according to compressor size and required wattage.
- Check the compressor application guidelines for crankcase heater connection and operation.
- Position the crankcase heater between the lower cover and the lower bearing weld projection (**Fig. 9**).
- Fit the heater horizontally around the crankcase, ensuring that it is in close contact with the compressor housing along the entire length.
- Avoid having the heating portion of the heater in contact with any weld projection (**Fig. 10 & 11**).
- Avoid having the assembly heater inclined (**Fig. 12**).
- Close the lock and tighten the screw, torque: 2-3 Nm.
- The excess clamp bracket may be trimmed. Sharp edges must not come into contact with wires.
- The presence of the heater shall be made evident by the posting of caution signs or markings at appropriate locations.



Figure 9



Figure 10



Figure 11



Figure 12

Electrical connection

- Connect the crankcase heater according to the compressor application guidelines.
- The crankcase heater must be connected only to its rated voltage.
- The metal braid of the heater must be connected to a suitable earthing terminal.
- Check the resistance according to the technical data.
- Perform an insulation test before start-up.
- Electrical security and safety measures are to be provided on site.

3.7 Soft starters

Copeland scroll fixed-speed compressors can generally be operated with soft starters. Soft starter versions and sizes should be selected according to the soft starter manufacturer's recommendations, taking into consideration the compressor amps. Normally, the ramp-up time should not exceed 1 second.

Due to the inherent design of the Copeland scroll, the internal compression components start unloaded, even if system pressures are not balanced. Since the compressor internal pressures are balanced at start-up, low voltage starting characteristics are excellent, and starting components are normally not required.

However, for extreme electrical conditions such as weak power supplies, single-phase soft starters can be supplied on request by Copeland, while three-phase soft starters are available on the market.

3.8 Discharge gas temperature protection



CAUTION

Inadequate lubrication! Scroll set damage! All YH*K1E compressors must be equipped with a discharge gas temperature protection.

A good system control shall prevent the system from operating outside the published operating envelope and acceptable superheat range, whatever the climatic conditions and the capacity demand. However, under some extreme operating conditions such as loss of charge or improper control operation, the internal discharge gas temperature reached can cause compressor damage. In order to ensure positive compressor protection, discharge gas temperature protection is required for any application with Copeland compressors.

The maximum discharge gas temperature is 135 °C for all YH*K1E compressor models.

Discharge gas temperature protection is the "fall-back" for failure of the system control. It is essential that proper control of both the evaporating and condensing pressures and the superheat is maintained and has the ability to cope with all likely conditions and high loads. Reliance on protectors will cause inadequate system performance and short cycling.

NOTE: The maximum discharge gas temperatures indicated in this chapter are valid for safe operation within the approved application envelope. The discharge temperature protection has the function of a compressor protection, it is not designed to control the operating envelope. For compressor envelope control, an additional control device or regulation must be used.

3.8.1 Excessive discharge gas temperatures

A few of the possible consequences of excessive discharge gas temperatures are listed below:

- Since the oil circulates in the system with the refrigerant, it is subjected to high discharge gas temperatures. If the discharge gas temperature becomes too high, the so-called "cooking" effect will occur (heating of oil under exclusion of air). Carbon deposits can form at points of high temperature, for example on the valves, oil channels, oil filters, etc. The oil lubricity will be reduced and a progressive wear process will occur which will prematurely damage the compressor.
- The stability of the refrigerant can also be affected, particularly if traces of contaminant are present.

The problems described above frequently occur simultaneously, particularly since the chemical reaction speed approximately doubles with every 10 °C temperature rise. This directly leads to chemical reactions of the oil with the refrigerant and the compounds extracted from sealants and insulation material. As a consequence, contaminants of various types, among them acids, will form inside the system.

3.8.2 Discharge temperature sensor NTC

YH*K1E compressors need an external discharge line temperature sensor. The correct reading of this sensor is fundamental for discharge line temperature control. The sensor must ensure high accuracy and acceptable dynamic behaviour.

Please follow the recommendations below for sensor assembly:

- The discharge temperature sensor must be installed along the straight or bended pipe at a distance of 120 mm from the compressor outlet.
- The discharge pipe including the sensor must be insulated to reduce the impact of ambient temperature.
- Use thermal compound to improve heat transfer to the sensor. The thermal compound must be approved for maximum system operating temperatures.
- Protect the sensor from being moved or removed from its position by transport, vibration or any other incident.
- The sensor must be installed in a copper sleeve to improve response time and to reduce setoff. The copper sleeve must be brazed on the surface of the discharge pipe. Use thermal compound to improve the heat transfer from the sleeve to the sensor.

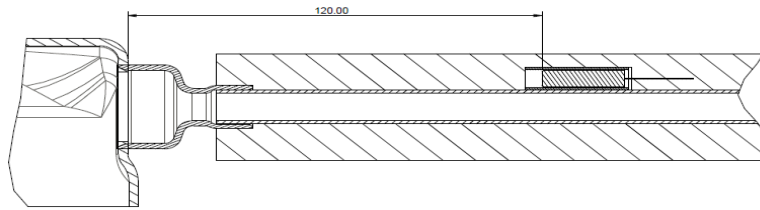

Figure 13: Sensor installation

For more recommendations about NTC mounting please refer to Copeland assembly instructions C30.11/0419/E.

3.9 Internal pressure relief valve

There is no internal pressure relief valve on the YH*K1E compressors covered in these guidelines.

3.10 Discharge check valve

YH*K1E compressors contain an internal low leak check valve on the discharge connection. The discharge check valve prevents the high-pressure discharge gas from rapidly flowing back through the compressor after shutdown.

NOTE: This check valve cannot be used with recycling pumpdown because it is not entirely leak-proof.

3.11 Filter screens



CAUTION

Screen blocking! Compressor breakdown! Use screens with at least 0.6 mm openings.

The use of filter screens finer than 30 x 30 mesh (0.6 mm openings) anywhere in the system should be avoided with these compressors. Field experience has shown that finer mesh screens used to protect thermal expansion valves, capillary tubes or accumulators can become temporarily or permanently plugged with normal system debris and block the flow of either oil or refrigerant to the compressor. Such blockage can result in compressor failure.

3.12 Mufflers

Gas flow through scroll compressors is continuous with relatively low pulsation. External mufflers may not be required on Copeland scroll compressors. Due to system variability, individual tests should be conducted by the system manufacturer to verify acceptable levels of sound and vibration.

If adequate attenuation is not achieved, use a muffler with a larger cross-sectional area to inlet area ratio. A ratio of 20:1 to 30:1 is recommended. A hollow shell muffler will work quite well. Locate the muffler at minimum 15 to maximum 45 cm from the compressor discharge for the most effective operation. The farther the muffler is placed from the compressor within these ranges, the more effective. Choose a muffler with a length of 10 to 15 cm.

3.13 Sound shell

Copeland has qualified sound shell kits for the YH*K1E compressor model range.

NOTE: Refer to the Copeland spare parts catalogue at www.copeland.com/en-gb/tools-resources to select the correct sound shell kits according to compressor model.

3.14 Insulation material

Insulation material is commonly used in a system to insulate the suction line, suction accumulator, expansion valve bulb or discharge line thermostat. When choosing the insulation material for A3 applications, particular attention shall be paid to its non-electrostatic properties, as it could be a potential ignition source.

3.15 Reversing valves

Since Copeland scroll compressors have a very high volumetric efficiency, their displacements are lower than those of comparable capacity reciprocating compressors. As a result, Copeland recommends that the capacity rating on reversing valves be no more than 1.5 to 2 times the nominal capacity of the compressor in order to ensure proper operation of the reversing valve under all operating conditions.

Caution: Reversing valve sizing must be within the guidelines of the valve manufacturer. The pressure drop required to ensure valve shifting must be measured throughout the operating range of the unit and compared to the valve manufacturer's data. Low ambient heating conditions with low flow rates and low pressure drop across the valve can result in a valve not shifting. This can lead to a condition where the compressor appears not to be pumping, ie, balanced pressures. It can also cause elevated compressor sound levels.

During a defrost cycle, when the reversing valve abruptly changes the refrigerant flow direction, the suction and discharge pressures will go outside of the normal operating envelope. The sound that the compressor makes during this transition period is normal, and the duration of the sound will depend on the heat exchanger (coil) volume, outdoor ambient, and system charge level. The preferred method of mitigating defrost sound is to shut down the compressor for 20 to 30 seconds when the reversing valve changes position going into and coming out of the defrost cycle. This technique allows the system pressures to reach equilibrium without the compressor running. The additional start-stop cycles do not exceed the compressor design limits, but suction and discharge tubing design and contactor life should be evaluated.

The reversing valve solenoid should be wired so that the valve does not reverse when the system is shut off by the operating thermostat in the heating or cooling mode. If the valve is allowed to reverse at system shut-off, suction and discharge pressures are reversed to the compressor. This results in pressures equalizing through the compressor which can cause the compressor to slowly rotate backwards until the pressures equalize. This condition does not affect compressor durability but can cause unexpected sound after the compressor is turned off.

3.16 Sound and vibration



WARNING

Vibrations! Creation of a flammable atmosphere! Carefully check the system for vibrations.

Vibrations during compressor operation can cause cracks which could lead to refrigerant leakage. This situation must be avoided by the system manufacturer/installer. To this end, the pipework must be carefully designed when connecting a scroll compressor to a system.

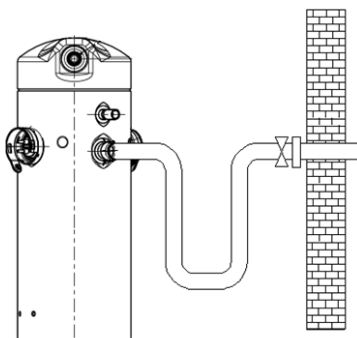

Figure 14: Example of suction tube design

A scroll compressor makes both a rocking and twisting motion and enough flexibility must be provided in the pipework to allow starting, stopping and steady state running of the compressor without transmitting excessive stress into any line attached to the unit. In a split system, the most important goal is to ensure minimal vibration in all directions to avoid transmitting vibrations to the structure to which the lines are fastened.

Under some conditions, the Copeland scroll has a normal starting rotational motion that can transmit a transient noise along the lines. This may be particularly pronounced in compressors using a three-phase motor due to their inherently higher starting torque. This phenomenon, like the one described previously, can easily be avoided by using standard line isolation techniques.

The sound level of a system is the result of design, quality and application. Scroll compressors sound power levels generally increase with the compressor model capacity and the condition pressure ratio.

3.17 Compressor oil return, oil balancing, refrigerant floodback and oil dilution tests



CAUTION

Inadequate lubrication! Bearing and moving parts destruction! Ensure adequate oil return from the system into the compressor at any time. No liquid refrigerant return to the compressor. Liquid refrigerant dilutes the oil, could wash the oil off the bearings and moving parts and could lead to overheating and compressor failure.

The system piping must be carefully designed to ensure sufficient refrigerant gas velocity, so that oil returns to the compressor at all times and conditions. Individual piping diameter calculation depends on the refrigerant properties, pressure level, mass flow and density.

For other system components such as suction accumulators, the extra amount of oil which will be required in the system must be checked with the suppliers of these components. If needed, the system should be pre-charged accordingly including the additional oil quantity.

Once a new system design is set and assembled, a functional test is required. The functional test includes a qualification for the general system oil return, a refrigerant floodback test and an oil dilution test. Systems with multiple compressors (two, three, or more) require additional oil balancing qualification between the parallel compressors.

A sample compressor equipped with an external oil sight tube can be ordered from Copeland for lab testing.

Records of the evaporating temperature and the bottom shell temperature shall be taken with a high sampling rate during the entire oil return or oil balance testing and under all tested conditions. The liquid level in the sight tube has to be observed and recorded too. Testing conditions shall include defrost and varying loads. If the system is reversible, the tests should be conducted in both operation modes.

System engineers should review the system design and operation to identify the critical conditions and to check oil return, oil balancing, liquid floodback and oil dilution. For discussion of individual test results and system behaviour, eg, with regard to oil dilution, please contact the Application Engineering department. Typically, the following situations should be considered:

- **In single compressor systems:** to check oil return, testing conditions shall be at minimum mass flow and minimum density of suction gas in continuous and frequent start/stop cycling.
- **In multiple compressor systems:** to check oil return and oil balancing in the tandem or trio, testing conditions shall be at the corner points of the system application envelope in continuous and frequent start/stop cycling.
- **In all systems:** to test liquid floodback and oil dilution, all possible transient operation conditions in the system should be checked, eg, compressor frequent start/stop, compressor start after long off time with migration, defrost, switching between the operation modes in reversible systems, load changes, fans or pumps cycling at low load and more. To evaluate the risk of liquid floodback and oil dilution, please refer to the chart in **Figure 15**.

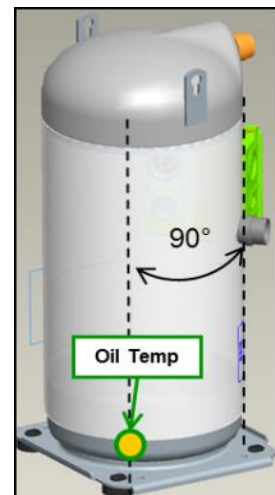
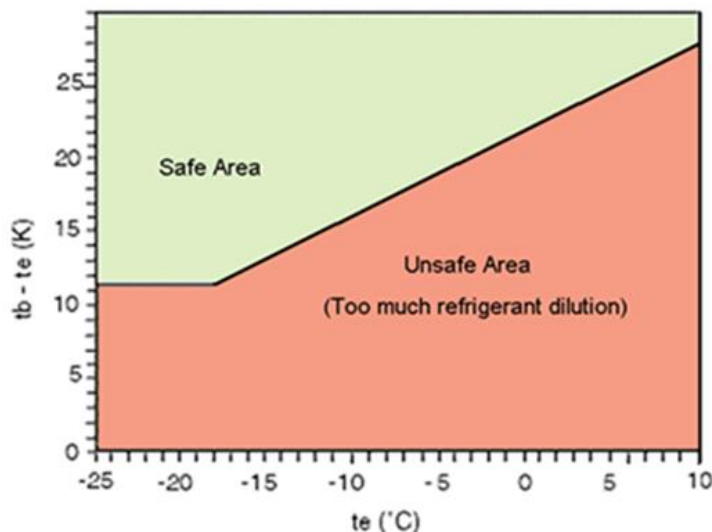

Figure 15: Oil dilution chart (t_b = bottom shell temperature; t_e = evaporating temperature) & position for oil temperature sensor

The bottom shell temperature together with the evaporating temperature gives an indication whether liquid refrigerant is returning or diluted in the compressor oil sump. The compressor sump temperature must remain in the (green) safe area, as shown in the chart in **Figure 15** above. In case of operation in the (red) unsafe area, adjustments are required in order to modify the system design, refrigerant charge or superheat setting of the expansion device(s). The bottom shell temperature should be measured accurately. The thermo-probe must be properly insulated and positioned at an angle of 90° clockwise from the suction inlet with view on the top.

3.18 Suction line accumulator

Due to Copeland scroll's inherent ability to handle liquid refrigerant, for example in flooded start and defrost cycle operation, an accumulator is not required in most systems.

To determine if a suction line accumulator is required, the system designer must check this with an appropriate test scenario. See **Chapter 3.17 "Compressor oil return, oil balancing, refrigerant floodback and oil dilution tests"**.

If an accumulator is used, the oil-return orifice should be sized depending on compressor size and compressor floodback results. To protect this small orifice from plugging with system debris a large-area protective screen no finer than 30 x 30 mesh (0.6 mm openings) is required. Tests have shown that a small screen with a fine mesh can easily become plugged causing oil starvation to the compressor bearings. The size of the accumulator depends upon the operating range of the system and the amount of sub-cooling and subsequent head pressure allowed by the refrigerant control. For the correct selection and size of the suction line accumulator, refer to the manufacturer's specifications.

Check with supplier whether an extra charge of oil for the suction accumulator is required. Pre-charge additional oil to the system accordingly.

4 Electrical connection

4.1 General recommendations



WARNING

Conductor cables! Electrical shock! Shut off power supply before undertaking any task on electrical equipment.



WARNING

Ignition source in a potentially flammable atmosphere! Fire hazard! The electrical connection of the scroll compressors is not an ignition source during normal operation but could become one when not installed properly according to installation instructions. Ensure correct mechanical and electrical installation. System capacitors may remain charged for several minutes after shutdown. Before starting to work on the electrical installation make sure sparking is not possible. Continuously check if the ambient atmosphere is non-flammable when working on the electrical installation.

The compressor terminal box has a wiring diagram on the inside of its cover. Before connecting the compressor, ensure the supply voltage, the phases and the frequency match the nameplate data.

For safety reasons, Copeland recommends that the electrical installation be executed in compliance with standard EN 60204-1 and/or other standards and regulations of application.

When installing YH*K1E compressors in a system, the following measures must be taken:

- To ensure the wires are properly terminated, the correct terminal and clamping tool for the selected wire size must be used.
- The ground wiring must conform to local regulations and codes of practice (only the provided parts must be used).
- The grounding screw must be torqued as per **Tables 9 & 10** in **section 4.3 "Terminal box"**.
- A cable strain-relief device must be added.
- The cable and wires must be protected against sharp edges.

4.2 Electrical installation

The recommended wiring diagrams are shown in **Figure 17** next page.

NOTE: A contactor K2 has to be used for the safety chain to comply with EN 60335 and EN 60204-1.

NOTE: It is recommended to install a residual current device (RCD) in any electrical system associated with YH*K1E compressors and flammable refrigerants such as R454C. The purpose of the RCD is to detect current leaks to the ground in case of electrical issues, for example with the terminal connection pins or other electrical accessories.



Figure 16: Residual current device (RCD)

Three-phase compressors (TF*) with internal motor protection:

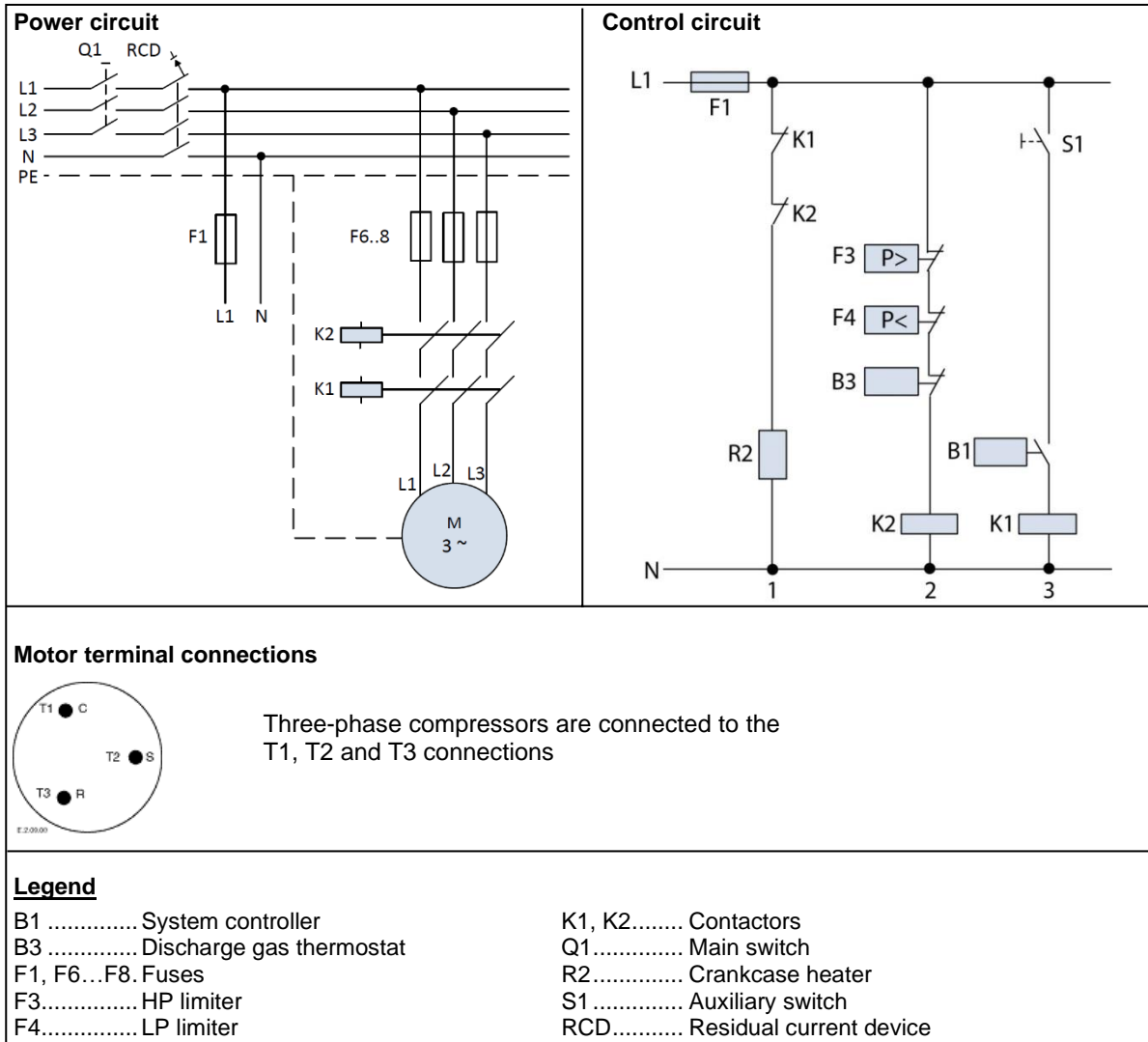

Figure 17: Wiring diagrams for YH*K1E

4.3 Terminal box



WARNING

Ignition source in a potentially flammable atmosphere! Fire hazard! Particular attention must be paid in A3-refrigerant systems as any work on the energized terminals in the compressor terminal box could create an ignition. Do not touch the energized terminals with a tool or cable when the compressor is energized. Compressors operating with flammable refrigerants shall use only the qualified terminal box supplied with the compressor.



CAUTION

Mechanical stress or shock! Overheating! Terminal Fusite damage and leakage! Mechanical stress and shocks to the Fusite must be avoided as they could damage the glass and/or ceramic. This might result in hermeticity failure or loss of terminal performance. Precautions are required to prevent striking or bending of pins. Bent or damaged pins may result in loss of hermeticity and/or terminal performance.

Ensure correct connection of cables to the compressor terminal Fusite to avoid local overheating of Fusite pins which might lead to refrigerant leaks.

Cable glands have an influence on the protection class of the terminal box. Copeland strongly recommends using appropriate cable glands according to EN 50262 in order to reach the rated protection class. Examples of correct electrical installations are shown in **Figures 18 & 19** below.

4.3.1 IP54 terminal box (BOM GCZ, GCY & GCW)

YH*K1E compressors with BOM GCZ, GCY and GCW are supplied with an IP54 terminal box.

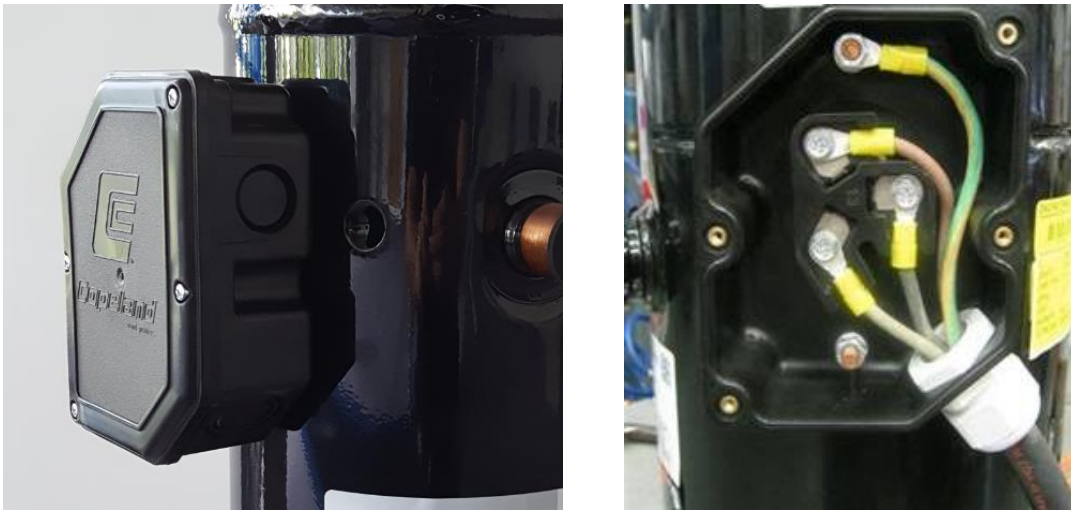

Figure 18: IP54 T-box and correct electrical installation with cable gland

Compressor	Torque grounding screw	Torque terminal screws
YH*K1E with IP54 T-box	2.4 - 2.6 Nm	2.8 - 3.5 Nm

Table 9: IP54 Terminal box tightening torques

4.3.2 IP65 metal terminal box (BOM JCE & JCD)

YH*K1E compressors with BOM JCE (single compressor) and JCD (tandem-ready compressor) are supplied with an IP65 metal terminal box.

The maximum thickness of cable connectors for the terminal block shall be 1 mm for all models – see Figure 19.

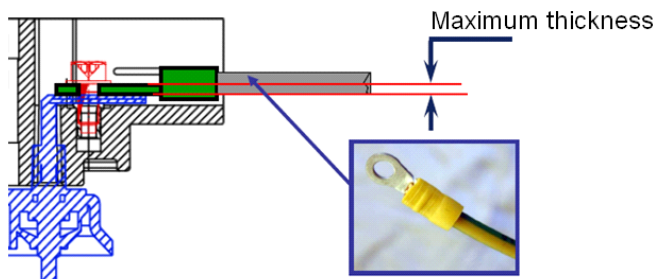

Figure 19: Maximum thickness of cable connectors

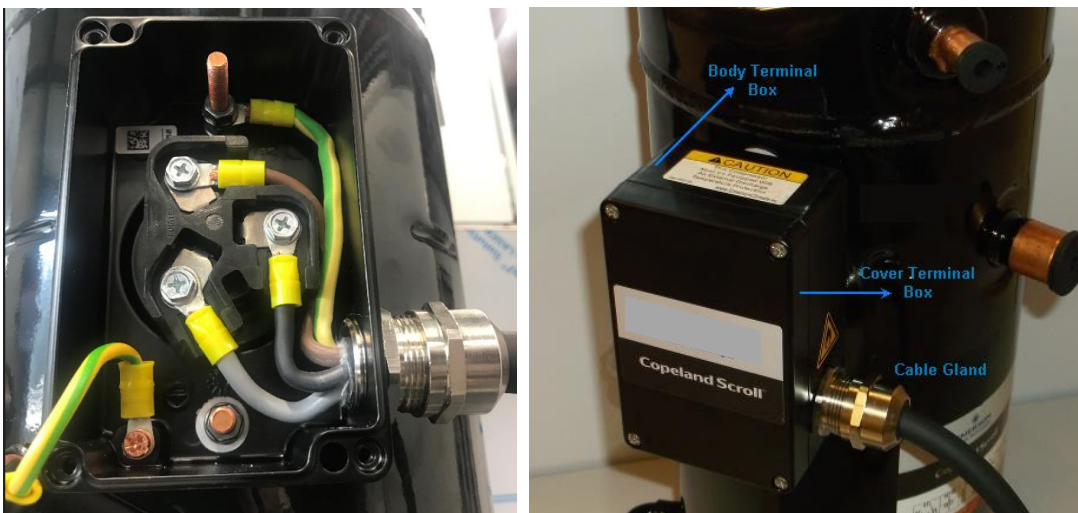

Figure 20: IP65 T-Box and correct electrical installation with cable gland

The first two nuts already installed on the Peko bolts shall not be removed, as they ensure good tightness of the terminal box assembly. Make sure to assemble the ground connection of the Peko bolt with a torque of 4 - 4.4 Nm and the ground connection between the cover and the body of the terminal box with a torque of 1.8 - 2 Nm – see **Table 10**.

Assemble the cable gland M25 with a torque of 9.8 - 10 Nm. The cable gland is designed for cable diameters of 10 to 17 mm – see **Figure 21 & Table 10**. The degree of protection (IP) will be safeguarded only if sealing and cable glands are properly assembled. Only run the compressor with permanently wired cables. The system manufacturer/installer shall provide the required strain relief.

Finally, close the cover of the terminal box applying a torque of 1.8 - 2 Nm. The degree of protection (IP) will be safeguarded only if the cover is properly assembled.

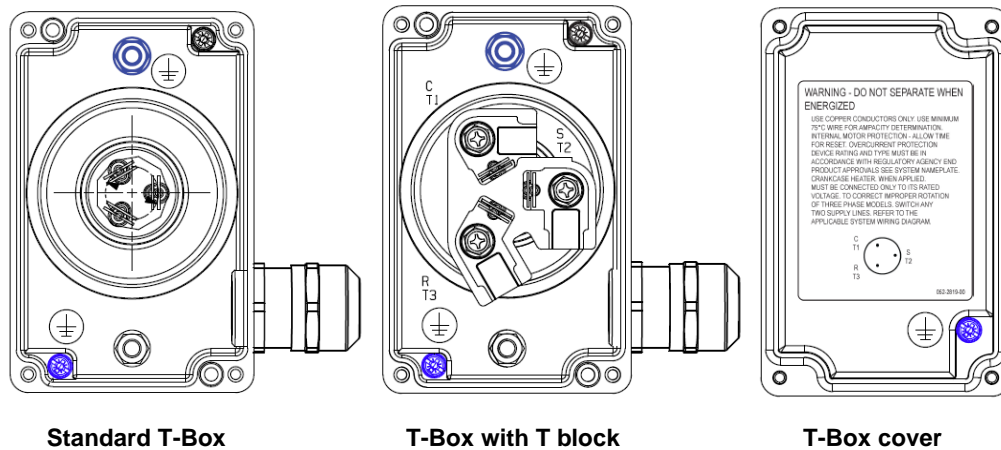

Figure 21: Terminal boxes



Item	Symbol	Torque (Nm)	Diameter
Grounding nut		4 - 4.4 Nm	
Cable gland		9.8 - 10 Nm	Cable 10 - 17 mm
Grounding screw		1.8 - 2 Nm	
Connection screws		2.8 - 3.5 Nm	

Table 10: IP65 Terminal box connections and torques

4.4 Motor insulation

The motor insulation material is class "B" (TF*) within maximum allowable operating temperatures according to IEC 34-1 or DIN 57530.

4.5 Motor protection

In addition to the internal motor protection, fuses must be installed before the compressor. The selection of fuses has to be made according to EN 60269-1 or EN 60204-1 and compressor maximum operating current (MOC). Not installing fuses before the compressor or selecting inappropriate fuses may result in compressor failure.

Conventional inherent internal line break motor protection is provided for the complete range of YH*K1E compressors.

4.6 High-potential testing



WARNING

High-potential testing in a flammable atmosphere! Fire hazard! Make sure the atmosphere is non-flammable before performing high-potential testing. Make sure the electrical connections are properly executed. Perform any high-potential test only after passing system strength and tightness tests according to EN 378.



WARNING

Conductor cables! Electrical shock hazard! Shut off power supply before high-potential testing.



CAUTION

Internal arcing! Motor destruction! Do not perform high-voltage or insulation tests if the compressor housing is under vacuum.

Copeland subjects all scroll compressors to a high-voltage test after final assembly. Each motor phase winding is tested according to EN 60034-1 at a differential voltage of 1000 V plus twice the nominal voltage.

Since high-voltage tests lead to premature ageing of the winding insulation, further additional tests of that nature are not recommended. However, if they are absolutely needed, they should be conducted with a lower voltage than described above. Disconnect all electronic devices, eg, motor protection module, fan speed control, etc. prior to testing.

Special attention should be paid when performing a high-potential test and reading the Megohm resistance on A2L compressors, as such tests can induce an electrical arc and cause a fire hazard.

For the same reason, compressors removed from an A2L-refrigerant system will need to have the oil drained and a nitrogen purge introduced to flush any remaining refrigerant from the compressor prior to high-potential testing and Megohm resistance reading.

5 Start-up & operation



WARNING

Diesel effect! System explosion! The mixture of air and oil at high temperature can lead to an explosion. Avoid operating with air.



WARNING

Air/flammable refrigerant mixture! Creation of a flammable atmosphere! Make sure the atmosphere is non-flammable before starting the system. Ensure that the system contains only refrigerant.

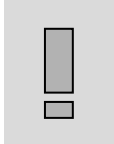

IMPORTANT

Oil dilution! Bearing malfunction! It is important to ensure that new compressors are not subjected to liquid abuse. It is recommended to have a crankcase heater installed if the refrigerant charge exceeds a defined value – see **Table 8**. Turn the crankcase heater on 12 hours before starting the compressor for the first time.

5.1 Strength-pressure test



WARNING

High pressure! Personal injuries! Consider personal safety requirements and refer to test pressures prior to test.



IMPORTANT

System contamination! Bearing malfunction! Use only dry nitrogen for pressure testing. DO NOT USE other industrial gases.

5.1.1 Compressor strength-pressure test

The compressor has been strength-pressure tested in the Copeland factory. Therefore, it is not necessary for the system manufacturer/installer to strength-pressure test the compressor again.

Scroll compressors are divided into two pressure zones. The compressor high-side and low-side maximum allowable pressures PS have to be respected at all times.

5.1.2 System strength-pressure test

A strength-pressure test of individual sections of the entire system is permitted. Once the compressor is isolated, the rest of the system can be tested with the required pressure values.

The strength-pressure test can also be conducted with the compressor connected, but in that case the two pressure zones of the scroll compressor need to be respected:

- System high-pressure section:
 - Define the system high-side PS \leq compressor high-side PS.
 - Isolate the high- and low-pressure sections of the system by closing valves, solenoid valves, expansion valves or by other means.
 - Use the internal check valve of the compressor on the discharge side or add an external check valve. To protect the compressor internal check valve, observe a maximum pressure delta of ≤ 40 bar between the high-pressure side and the low-pressure side.
 - Activate the check valve with a fast pressure increase. Once the check valve is activated, the pressure increase can be slowed down.
 - At this stage the system test pressure of 1.1 x system high-side PS can be applied for a short time.
 - During the system test, make sure the pressure inside the compressor does not exceed the maximum PS value, which corresponds to the compressor low-pressure PS.
- System low-pressure section:
 - Define the system low-side PS \leq compressor low-side PS.
 - The system test pressure of 1.1 x system low-side PS can be applied for a short time.

5.2 Compressor tightness test



WARNING

High pressure! Personal injuries! Consider personal safety requirements and refer to test pressures prior to test.



IMPORTANT

System contamination! Bearing malfunction! Use only dry inert gases, eg, nitrogen, for leak testing. DO NOT USE other industrial gases.

The compressor has been leak-pressure tested in the Copeland factory.

All compressors get a factory holding charge of dry air (about 1 to 2.5 bar, relative pressure). The presence of an intact holding charge serves as a proof of quality against penetrating moisture.

When removing plugs from the compressor, the plugs may pop out due to pressure and oil can spurt.

Any later modification to compressor connections can have an impact on the compressor tightness. Always leak-pressure test the compressor after opening or modifying the connections.

Never add refrigerant to the test gas (as leak indicator).

5.3 System evacuation

Before the installation is put into commission, it has to be evacuated with a vacuum pump. The vacuum pump and all tools have to be approved for A2L refrigerant/air mixture. The system should be evacuated down to an absolute pressure of 2.7 mbar or to a minimum moisture level of 50 ppm. During the initial procedure, suction and discharge shut-off valves on the compressor remain closed. The installation of adequately sized access valves at the furthest point from the compressor on the suction and liquid lines is advisable. The pressure must be measured using a vacuum pressure gauge on the access valves and not on the vacuum pump; this serves to avoid incorrect measurements resulting from the pressure gradient along the connecting lines to the pump.

Evacuating the system only on the suction side of a scroll compressor can occasionally result in a temporary no-start condition for the compressor. The reason for this is that the floating seal could axially seal with the scroll set, with the higher pressure on the floating seal. Consequently, until the pressures equalise, the floating seal and scroll set can be held tightly together.

The highest demands are placed on the leak-proof design of the installation and on the leak testing methods – please refer to EN 378.

When working on systems filled with refrigerant, it may be necessary to repeat the evacuation process several times. Refrigerant may have dissolved in the refrigerant oil and will only gradually condense out.

5.4 Preliminary checks – Pre-starting



WARNING

Air/A2L refrigerant mixture in a potentially flammable or explosive atmosphere! Fire and explosion hazard! Whenever starting up a system charged with A2L refrigerant, eg, after filling, repair, or maintenance, make sure not to start and operate accidentally in a flammable or explosive atmosphere.

Discuss details of the installation with the installer. If possible, obtain drawings, wiring diagrams, etc. It is ideal to use a check-list but always check the following:

- no explosive atmosphere or flammable gas in the ambient;
- suitable ventilation according to the room volume and to the refrigerant charge;
- visual check of the electrics, wiring, fuses etc;
- visual check of the plant for leaks, loose fittings such as TXV bulbs etc;
- compressor oil level;
- calibration of HP & LP switches and any pressure actuated valves;
- check setting and operation of all safety features and protection devices;
- all valves in the correct running position;
- pressure and compound gauges fitted;
- correctly charged with refrigerant;
- compressor electrical isolator location & position.

5.5 Charging procedure



WARNING

Air/A2L refrigerant mixture in a potentially flammable or explosive atmosphere! Fire and explosion hazard! Only use filling equipment designed and approved for use and operation with A2L refrigerants. Make sure all connections are tight to avoid leakage. Make sure to fill with pure A2L refrigerant.



CAUTION

Low suction pressure operation! Compressor damage! Do not operate compressor with a restricted suction or with the low-pressure limiter bridged. Do not operate at pressures that are not allowed by the operating envelope. Allowing the suction pressure to drop below the envelope limit for more than a few seconds may overheat scrolls and cause early drive bearing and moving parts damage.

Prior to charging or re-charging, the refrigerant system must be leak- and pressure-tested with appropriate purging gas.

Ensure that the system is grounded prior to charging with refrigerant.

The system shall be liquid-charged through the liquid-receiver shut-off valve or through a valve in the liquid line. The use of a filter-dryer in the charging line is highly recommended. Systems shall be liquid-charged on both the high and low sides simultaneously to ensure a positive refrigerant pressure is present in the compressor before it runs. The majority of the charge shall be placed in the high side of the system to prevent bearing washout during first-time start on the assembly line.

Extreme care shall be taken not to overfill the system with refrigerant.

NOTE: The system manufacturer/installer must respect the charge limitations according to valid standards, such as EN 378.

5.6 Run-in time

Scroll compressors exhibit a slight decrease in input power during the initial running period. Published performance ratings are based on calorimeter testing which is carried out after run-in. Therefore, users should be aware that before the performance specified by EN 12900 is achieved the compressor needs to be run in. Recommended run-in times for YH*K1E compressors to attain the published performance are 16 hours at the standard conditions.

5.7 Initial start-up



CAUTION

High discharge pressure operation! Compressor damage! Do not use compressor to test opening setpoint of high-pressure cut-out. Internal parts are susceptible to damage before they have had several hours of normal running in.

Liquid and high-pressure loads could be detrimental to new bearings. It is therefore important to ensure that new compressors are not subjected to liquid abuse and high-pressure run tests. It is not good practice to use the compressor to test the high-pressure switch function on the production line. The switch function can be tested with nitrogen prior to installation and the wiring can be checked by disconnecting the high-pressure switch during the run test.

5.8 Rotation direction

Scroll compressors, like several other types of compressors, will only compress in one rotational direction. Three-phase compressors will rotate in either direction depending upon the phasing of the power. Since there is a 50-50 chance of connecting power in such a way as to cause rotation in the reverse direction, **it is important to include notices and instructions in appropriate locations on the equipment to ensure proper rotation direction when the system is installed and operated.**

Observing that suction pressure drops and discharge pressure rises when the compressor is energized allows verification of proper rotation direction. There is no negative impact on durability caused by operating three-phase Copeland scroll compressors in the reverse direction for a short period of time (under one hour) but oil may be lost. Oil loss can be prevented during reverse rotation if the tubing is routed at least 15 cm above the compressor. After several minutes of operation in reverse, the compressor protection system will trip due to high motor temperature. The operator will notice a lack of cooling. However, if allowed to repeatedly restart and run in reverse without correcting the situation, the compressor will be permanently damaged.

All three-phase scroll compressors are identically wired internally. Therefore, once the correct phasing is determined for a specific system or installation, connecting properly phased power leads to the identified compressor terminals will ensure proper rotation direction.

5.9 Start-up and shut-off sound

During the very brief start-up, a clicking sound resulting from the initial contacting of the spirals is audible; this sound is normal. Due to the design of the Copeland scroll compressors, the internal compression components always start unloaded even if system pressures are not balanced. In addition, since internal compressor pressures are always balanced at start-up, low voltage starting characteristics are excellent for Copeland scroll compressors.

Scroll compressors incorporate a device that minimizes reverse rotation. The residual momentary reversal of the scrolls at shut-off will cause a clicking sound, but it is entirely normal too and it has no effect on compressor durability.

5.10 Deep vacuum operation



CAUTION

Vacuum operation! Compressor damage! Copeland scroll compressors should never be used to evacuate refrigeration or air-conditioning systems. Operating scroll compressors in deep vacuum could damage internal motor parts and lead to unacceptable high temperatures in the compressor housing.

For flammable refrigerant operation below atmospheric pressure, see **section 3.5 "System protection for operation below atmospheric pressure"**.

5.11 Pumpdown cycle



WARNING

Operation below atmospheric pressure! Fire hazard! During operation of A2L-refrigerant systems below atmospheric pressure, a flammable mixture can form inside the system. Ensure system tightness to prevent any ingress of air.



CAUTION

Vacuum operation! Compressor damage! Compressor operation outside the operating envelope is not allowed.

A pumpdown cycle to control refrigerant migration may have to be used for several reasons, for example when the compressor is located outdoors without any housing so that cold air blowing over the compressor makes the crankcase heater ineffective.

If a pumpdown cycle is used, a separate external check valve must be added. The scroll discharge check valve is designed to stop extended reverse rotation and prevent high-pressure gas from leaking rapidly into the low side after shut-off. The check valve might in some cases leak, causing the scroll compressor to recycle more frequently. Repeated short cycling of this nature can result in a low oil situation and consequent damage to the compressor. The hysteresis of the low-pressure control differential has to be reviewed since a relatively large volume of gas will re-expand from the high side of the compressor into the low side after shutdown.

For pressure control setting, never set the low-pressure limiter to shut off outside of the operating envelope. To prevent the compressor from running into problems during such faults as loss of charge or partial blockage, the low-pressure limiter shall not be set lower than the minimum suction pressure allowed by the operating envelope.

NOTE: Refer to section 3.5 "System protection for operation below atmospheric pressure" for further information.

5.12 Shell temperature

During normal operation, the discharge gas as well as the compressor top shell and discharge line can reach temperatures up to the maximum discharge gas temperature of 135 °C – see **section 3.8 "Discharge gas temperature protection"**.

In a failure mode, the discharge gas temperatures can even get higher. Care must be taken to ensure that wiring or other materials that could be damaged by these temperatures do not touch the shell.

5.13 Minimum run time

Copeland recommends a maximum of 10 starts per hour. There is no minimum off time because scroll compressors start unloaded, even if the system has unbalanced pressures. The most critical consideration is the minimum run time required to return oil to the compressor after start-up. To establish the minimum

run time, a sample compressor equipped with an external oil sight glass is available from Copeland. The minimum on time becomes the time required for oil lost during compressor start-up to return to the compressor sump and to restore a minimal oil level that will ensure oil pick-up through the crankshaft. Cycling the compressor for a shorter period than this, for instance to maintain very tight temperature control, will result in progressive loss of oil and damage to the compressor.

5.14 Supply frequency and voltage

There is no general release of standard Copeland scroll compressors for use with variable-speed AC drives. A number of considerations must be taken into account when applying scroll compressors with variable speed, including system design, inverter selection, and operating envelopes at various conditions. Only frequencies from 50 to 60 Hz are acceptable.

The third letter of the motor code indicates which frequency and voltage must be applied – see **section 2.2 "Nomenclature"**.

For example, motor code TFDN:

- T = Three-phase motor
- F = Internal motor protection
- D = Voltage and frequency range
- N = Not approved by UL

50 Hz	60 Hz	Code
380-420 V / 3 ph	460 V / 3 ph	D

Table 11: Explanation of the 3rd letter of the electrical code

5.15 Oil level

There is no oil sight glass on YH*K1E compressors to ensure maximum hermeticity and compliance with EN 378.

The oil return depends on the system design. During the system development phase, adequate oil return from the system to the compressor should be evaluated and qualified. For this purpose, a sample compressor, equipped with an external oil sight tube, can be ordered from Copeland for lab testing. See also the information in **section 3.17 "Compressor oil return, oil balancing, refrigerant floodback and oil dilution tests"**.

Once the sample compressor with external sight tube is received, it is recommended to mark the minimum and nominal levels in terms of volume (l) and height (mm) starting from the baseplate – see **Figure 22** below for details. The maximum oil level is the upper end of the sight tube.

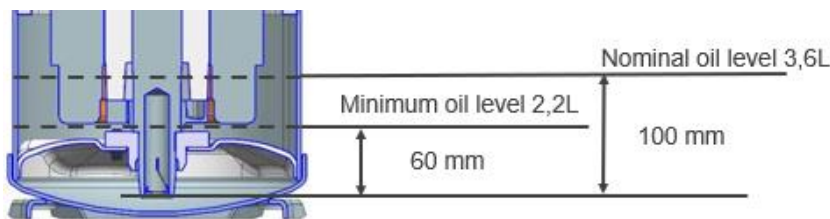

Figure 22: Sample Copeland scroll compressor with minimum and nominal oil levels

During operation, the liquid level in the external sight tube should remain between the minimum and maximum oil levels. Test recommendations are available on request from the Application Engineering department at Copeland. In case of unacceptable oil levels outside the minimum and maximum limits, please contact Application Engineering.

6 Maintenance & repair



WARNING

Conductor cables! Electrical shock hazard! Follow the lockout/tag out procedure and the national regulations before carrying out any maintenance or service work on the system.

Use compressor with grounded system only. Screwed electrical connections must be used in all applications. Refer to original equipment wiring diagrams. Electrical connections must be made by qualified electrical personnel.



WARNING

Ignition source in a potentially flammable or explosive atmosphere! Fire and explosion hazard! When opening an A2L refrigerant system, the atmosphere could be flammable or explosive. All electrical components that are a source of ignition must always be switched off during service and maintenance. Ensure that the surface temperatures of the components never exceed the limits set by the applicable safety standard, eg, EN 378-2.

Air/flammable refrigerant mixture! Fire and explosion hazard! Remove all the refrigerant before opening the system. Make sure to remove refrigerant completely from all components such as heat exchangers, refrigerant accumulators, etc. Flush the system and the components with inert gas before undertaking any work and before brazing.



WARNING

Open flame in a potentially flammable or explosive atmosphere! Fire and explosion hazard! The area shall be checked with an appropriate refrigerant detector prior to and during work on an A2L refrigerant system, to ensure the technician is aware of a potentially toxic or flammable atmosphere. Ensure that the leak detection equipment is suitable for all applicable refrigerants.

Personnel performing work on a refrigeration system that involves exposing the pipework shall avoid using any ignition source in a way that could lead to a fire or explosion hazard. All sources of ignition shall be kept sufficiently far from the site of installation, repair, removal or disposal during the entire time when refrigerant could be released into the surrounding space.

Open flames and smoking are strictly forbidden at all times.

During service make sure that:

- the area is well ventilated;
- the materials and equipment used are suitable for use under flammable conditions;
- only non-sparking tools are used;
- antistatic gloves and clothes are used;
- build-up of electrostatic charges is avoided;
- no unshielded or naked flame is used;

If parts of the refrigeration system are charged with flammable refrigerant, make sure that all the valves are tightly closed and that the open pipes after the valves are free of refrigerant and oil.

A risk analysis to evaluate all possible risks shall be carried out by the service technician before any repair work.

6.1 Qualification of workers

Personnel working on the maintenance, repair and decommissioning of the system shall be adequately trained. Any work procedure affecting safety shall only be executed by qualified and trained personnel in compliance with national or other equivalent certification systems.

Examples of such work procedures include breaking into the refrigerating circuit, opening sealed components, opening ventilated enclosures, etc...

6.2 Preparation and work procedure

A work procedure shall be provided in the preparation stage. All personnel working at the site, whether maintenance or other, shall be instructed on the nature of the work being carried out.

If any work is to be conducted on the refrigeration systems or any associated parts, appropriate fire extinguishing equipment shall be provided. Dry powder or CO₂ fire extinguishers are considered appropriate. Verify that appropriate fire extinguishing equipment is available near the work area.

Prior to starting to work on systems containing flammable refrigerants, safety checks are necessary to ensure that the risk of ignition is minimized.

Work shall be undertaken under a controlled procedure so as to minimize the risk of a flammable gas or vapour being present while the work is being performed.

Avoid working on systems filled with flammable refrigerant in a confined space.

6.3 Disassembling system components

The recommendations below shall be observed when disassembling system components:

1. For A1 refrigerant systems (R407C and R134a), recover refrigerant and evacuate system using a recovery unit and vacuum pump. All the refrigerant shall be recovered to avoid significant release.
2. For A2L refrigerant systems (R454C), recover refrigerant and evacuate system using an A2L-dedicated recovery unit and vacuum pump. Ensure that the outlet of the vacuum pump is not close to any potential ignition source and that ventilation is available.
3. Flush system with inert gas (dry nitrogen). Compressed air or oxygen shall not be used for purging refrigerant systems.
4. For A2L-refrigerant systems, the procedure of evacuation and flushing with oxygen-free nitrogen may need to be repeated until no refrigerant is present in the system. When the final nitrogen charge is used, the system shall be vented down to atmospheric pressure to enable work to take place.
5. Disassemble components with a cutting tool.
6. Drain, recover and dispose of compressor oil as appropriate.

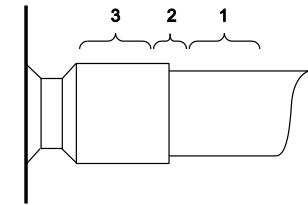

To disconnect:

- Using a pipe cutting tool, cut off the suction and discharge lines in such a manner that the new compressor can easily be re-connected into the system.
- Heat joint areas 2 and 3 slowly and uniformly until the braze material softens and the tube end can be pulled out from the fitting.

Figure 23: Tube connecting areas

To reconnect:

- Recommended brazing material: Silfos with minimum 5 % silver or silver braze used on other compressors.
- Due to the different thermal properties of steel and copper, brazing procedures may have to be changed from those commonly used.

NOTE: Since the discharge stub contains a check valve, care must be taken not to overheat it to prevent brazing material from flowing into it.

6.4 Exchanging the refrigerant



WARNING

Air/A2L refrigerant mixture in a potentially flammable or explosive atmosphere! Fire and explosion hazard! Avoid air/A2L mixture in the refrigeration system in any case. Make sure that the system is filled with pure A2L refrigerant. If the refrigerant needs replacing, the charge should be recovered using A2L-qualified refrigerant recovery unit and recycling bottles.



CAUTION

Low suction pressure operation! Compressor damage! Do not operate compressor with a restricted suction or with the low-pressure limiter bridged. Do not operate at pressures that are not allowed by the operating envelope. Allowing the suction pressure to drop below the envelope limit for more than a few seconds may overheat scrolls and cause early drive bearing and moving parts damage.

For qualified refrigerants and oil, see **section 2.4.1**.

It is not necessary to replace the refrigerant unless contamination, for example due to an error such as topping up the system with a non-condensable gas or incorrect refrigerant is suspected. To verify correct refrigerant composition, a sample can be taken for chemical analysis. A check can be made during shutdown by comparing the refrigerant temperature and pressure using precision measurements at a location in the system where liquid and vapour phases are present and when the temperatures have stabilised.

6.5 Replacing a compressor



CAUTION

Inadequate lubrication! Bearing destruction! For systems with a refrigerant accumulator, exchange the accumulator after replacing a compressor with a burned-out motor. The accumulator oil return orifice or screen may be plugged with debris or may become plugged. This will result in starvation of oil to the new compressor and a second failure.

Thoroughly remove refrigerant and oil from the replaced compressor.

6.5.1 Compressor replacement

When replacing an A2L-refrigerant compressor, the oil has to be drained out of the compressor and the compressor should be flushed with dry nitrogen. DO NOT close the stubs with plugs.

In case of motor burnout, most of the contaminated oil will be removed with the compressor. The rest of the oil is cleaned through the use of suction and liquid line filter-dryers. A 100 % activated alumina filter-dryer is recommended for the suction line. It must be removed after 72 hours.

It is highly recommended to replace the suction accumulator if the system contains one. This is because the accumulator oil return orifice or screen may be plugged with debris or may become plugged shortly after a compressor failure. This will result in starvation of oil to the replacement compressor and a second failure.

When a single compressor or tandem is exchanged in the field, it is possible that a large portion of the oil remains in the system. While this may not affect the reliability of the replacement compressor, the extra oil will add to rotor drag and increase power usage.

6.5.2 Start-up of a new or replacement compressor

Rapid charging only on the suction side of a scroll-equipped system can occasionally result in a temporary no-start condition for the compressor. The reason for this is that, if the flanks of the scrolls happen to be in a sealed position, rapid pressurisation of the low side without opposing high-side pressure can cause the scrolls to seal axially. As a result, until the pressures eventually equalise, the scrolls can be held tightly together preventing rotation. The best way to avoid this situation is to charge on both the high and low sides simultaneously at a rate which does not result in axial loading of the scrolls.

A minimum suction pressure specified in the published operating envelope must be maintained during charging. Allowing the suction pressure to drop below that value may overheat the scrolls and cause early drive bearing and moving parts damage.

Never install a system in the field and leave it unattended when it has no charge, a holding charge, or with the service valves closed without securely electrically locking out the system. This will prevent unauthorised personnel from accidentally operating the system and potentially ruining the compressor by operating with no refrigerant. **Do not start the compressor while the system is in a deep vacuum.** Internal arcing may occur when a scroll compressor is started in a vacuum causing burnout of the internal lead connections.

6.5.3 Compressor return procedure

For A1-refrigerant systems, if a compressor has to be returned to the manufacturer for analysis, the refrigerant must be thoroughly removed before shipment. The compressor can be shipped with the oil filling inside and closed connections.

For A2L-refrigerant systems, both the refrigerant and the oil must be thoroughly removed before shipment. All compressor connections must remain open and warning stickers for flammable refrigerant must be placed on the shipping box. The recommendations and procedure below shall be followed:

- During the entire working procedure continuously check if the ambient atmosphere is flammable or explosive. If a flammable or explosive atmosphere is detected, ensure proper ventilation of the working space and immediately cut-off the power supply.
- Resume working after the atmosphere is no longer dangerous.
- Recover the refrigerant from the system using a suitable recovery unit. During this action, the compressor crankcase heater could be energized – immediately de-energize in case a flammable or explosive atmosphere is detected.
- Recover to 2.7 mbar absolute pressure or lower. For best results and to recover also the refrigerant solved in the oil, run the recovery unit two or three times as necessary. Both the refrigerant and the oil must be thoroughly removed. Flush the whole system with oxygen-free dry nitrogen.
- Open the system with a cutting tool and flush the entire system with dry nitrogen again.

- Disassemble the compressor with a cutting tool. Drain and recover compressor oil properly. Flush the compressor with dry nitrogen for a few minutes.
- The compressor should be returned free of oil and with connections open – do not close connections with plugs.
- Collect and secure the oil properly. Provide information about the quantity of oil drained from the compressor and its colour. Ideally, send a good picture.
- Dispose of the oil according to local rules and regulations.
- Use a proper cardboard box package when preparing the compressor for shipment. Place warning



icons on each side and on the top of the box. Mention the following message on the box: **"Warning! Flammable A2L refrigerant compressor for analysis"**.

- The compressor box must be kept in the upright position – mark the box accordingly.
- If more than one compressor must be returned, each compressor has to be packed individually.

NOTE: Check with the transport company that all the requirements applying to such shipments are complied with.

6.6 Lubrication and oil removal



WARNING

Air/A2L refrigerant mixture in a potentially flammable or explosive atmosphere! Fire and explosion hazard! Use suitable recovery unit and recycling bottles also for oil disposal as A2L refrigerant may still be dissolved in the oil.



CAUTION

Chemical reaction! Compressor destruction! Do not mix up ester oils with mineral oil and/or alkyl benzene when used with chlorine-free (HFC) refrigerants.

The compressor is supplied with an initial oil charge. The standard oil for use with YH*K1E compressors is a polyolester (POE) Emkarate RL32 3MAF lubricant. See nameplate for original oil charge shown in litres. A field recharge is from 0.05 to 0.1 litre less.

One disadvantage of POE oil is that it is far more hygroscopic than mineral oil – see **Figure 23**. Only brief exposure to ambient air is needed for POE to absorb sufficient moisture to make it unacceptable for use in a refrigeration system. Since POE holds moisture more readily than mineral oil it is more difficult to remove it through the use of vacuum.

Copeland compressors contain oil with low moisture content, which however may rise during the system assembling process. Therefore, it is recommended to install a properly sized filter-dryer in all POE systems to maintain the moisture level in the oil to less than 50 ppm. If POE oil is charged into a system, it is recommended that its moisture content be no higher than 50 ppm.

If the moisture content of the oil in a system reaches unacceptably high levels, corrosion and copper plating may occur. The system should be evacuated down to 2.7 mbar in accordance with EN 378-4. Sight glass/moisture indicators can be used with HFC refrigerants and lubricants. However, they will only show the moisture content of the refrigerant. The actual moisture level in the oil is likely to be higher than indicated by the sight glass. If there is uncertainty as to the moisture content in the system, an oil sample should be taken and tested.

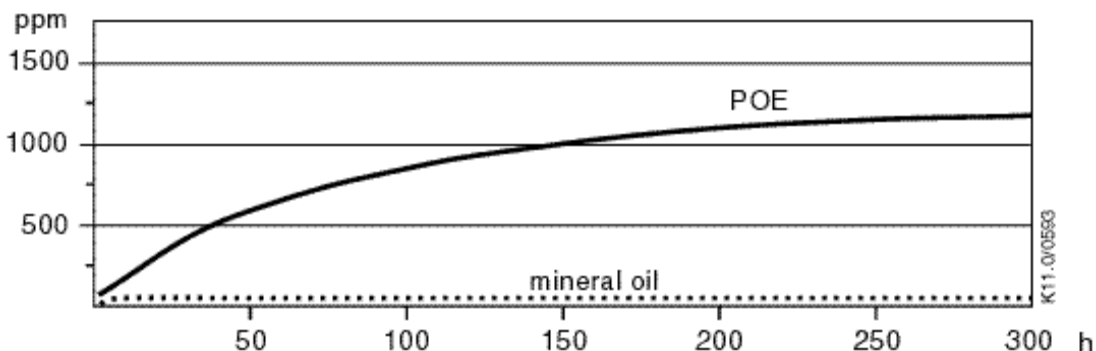

Figure 24: Absorption of moisture in ester oil in comparison to mineral oil in ppm by weight at 25 °C and 50% relative humidity (h=hours)

6.7 Oil additives

Although Copeland cannot comment on any specific product, from our own testing and past experience, we do not recommend the use of any additives to reduce compressor bearing losses or for any other purpose. Furthermore, the long-term chemical stability of any additive in the presence of refrigerant, low and high temperatures, and materials commonly found in refrigeration systems is complex and difficult to evaluate without rigorously controlled chemical laboratory testing. The use of additives without adequate testing may result in malfunction or premature failure of components in the system and, in specific cases, in voiding the warranty on the component.

7 Dismantling & disposal



Removing oil and refrigerant:

- Do not disperse refrigerant in the environment.
- Use the correct equipment and method of removal.
- Dispose of oil and refrigerant in accordance with national legislation and regulations.

Dispose of compressor in accordance with national legislation and regulations.

8 References

Please visit www.copeland.com/en-gb for free download of Application Guidelines and Technical Information.

Performance and technical data:

The latest version of Copeland Select software with performance data and technical data is available from the webpage www.copeland.com/en-gb/tools-resources.

Spare parts and accessories:

An online version of the Copeland spare parts and accessories catalogue is available from the webpage www.copeland.com/en-gb/tools-resources.

Additional technical documentation:

Technical Information TI_Scroll_HP_YH_Multiple_EN "Paralleling of YH*K1G Copeland Scroll Compressors for Heat Pump Applications" available at www.copeland.com/en-gb.

DISCLAIMER: The Copeland logo is a trademark and service mark of Copeland LP or one of its affiliates. Copeland Europe GmbH shall not be liable for errors in the stated capacities, dimensions, etc., as well as typographic errors. Products, specifications, assumptions, designs and technical data contained in this document are subject to modification by us without prior notice. Illustrations are not binding. ©2024 Copeland LP. All rights reserved.

BENELUX

Josephinastraat 19
NL-6462 EL Kerkrade
Tel: +31 45 535 06 73
Fax: +31 45 535 06 71
benelux.sales@copeland.com

GERMANY, AUSTRIA & SWITZERLAND

Theo-Mack-Str. 3
DE-63477 Maintal
Tel: +49 6109 605 90
cde.sales@copeland.com

FRANCE, GREECE & MAGHREB

8, Allée du Moulin Berger
FR-69134 Ecully Cédex,
Technoparc - CS 90220
Tel: +33 4 78 66 85 70
Fax: +33 4 78 66 85 71
mediterranean.sales@copeland.com

ITALY

Via Ramazzotti, 26
IT-21047 Saronno (VA)
Tel: + 39 02 9713 8060
Fax: +39 02 96 17 88 88
italy.sales@copeland.com

SPAIN & PORTUGAL

C/ Pujades, 51-55 Box 53
ES-08005 Barcelona
Tel: +34 93 412 37 52
iberica.sales@copeland.com

CZECH REPUBLIC

Hajkova 22
CZ - 133 00 Prague
Tel: +420 733 161 651
Fax: +420 271 035 655
Pavel.Sudek@copeland.com

ROMANIA & BULGARIA

Str. Alexandru Vaida Voevod Nr. 53B, Et. 5
400436, Cluj-Napoca, Romania
Tel: +40 364 821 680
ro-bg.sales@copeland.com

ASIA PACIFIC

Suite 2503-8, 25/F., Exchange Tower
33 Wang Chiu Road, Kowloon Bay
Kowloon, Hong Kong
Tel: +852 2866 3108
Fax: +852 2520 6227

UK & IRELAND

Tel: +44 1189 83 80 00
Fax: +44 1189 83 80 01
uk.sales@copeland.com

SWEDEN, DENMARK, NORWAY & FINLAND

Pascalstr. 65
DE-52076 Aachen
Tel: +49 2408 929 0
Fax: +49 2408 929 525
nordic.sales@copeland.com

EASTERN EUROPE & TURKEY

Pascalstr. 65
DE-52076 Aachen
Tel: +49 2408 929 0
Fax: +49 2408 929 525
easterneurope.sales@copeland.com

POLAND

ul. Konstruktorska 13
PL-02673 Warsaw
Tel: +48 22 458 92 05
Fax: +48 22 458 92 55
poland.sales@copeland.com

BALKAN

Selska cesta 93
HR-10 000 Zagreb
Tel: +385 1 560 38 75
Fax: +385 1 560 38 79
balkan.sales@copeland.com

MIDDLE EAST & AFRICA

PO Box 26382
Jebel Ali Free Zone - South, Dubai - UAE
Tel: +971 4 811 81 00
Fax: +971 4 886 54 65
mea.sales@copeland.com

For more details, see copeland.com/en-gb

Copeland Europe GmbH
Pascalstrasse 65 - 52076 Aachen, Germany
Tel. +49 (0) 2408 929 0 - Fax: +49 (0) 2408 929 570 - Internet: copeland.com/en-gb

The Copeland logo is a trademark and service mark of Copeland LP or one of its affiliates. Copeland Europe GmbH shall not be liable for errors in the stated capacities, dimensions, etc., as well as typographic errors. Products, specifications, assumptions, designs and technical data contained in this document are subject to modification by us without prior notice. Illustrations are not binding. ©2024 Copeland LP. All rights reserved.

COPELAND