

GENERAL PRECAUTIONARY INFORMATION

THIS CONTROL MUST BE INSTALLED BY A QUALIFIED INSTALLER.

All wiring must conform to local and national electrical codes and ordinances.

⚠ WARNING

Do not use on circuits exceeding specified voltage. Higher voltages will damage control and could cause shock or fire hazard

NOTE

If power disconnect switch is not in sight, lock it in the OFF position and tag it to prevent unexpected application of power.

⚠ CAUTION

To prevent electrical shock and/or equipment damage, disconnect electric power to system at main fuse or circuit breaker box until installation is complete.

Label all wires prior to disconnection when servicing controls. Wiring errors can cause improper and dangerous operation.

Following installation or replacement, follow appliance manufacturers' recommended installation/service instructions to insure proper operation.

DESCRIPTION

The fan control center provides low voltage control of line voltage circuits and can be used to control two-speed blower motors and auxiliary circuits in heating or cooling equipment.

FEATURES:

- Class II (40 V.A.) inherently energy limiting transformer
- Nonresettable, nonreplaceable overcurrent protection
- For general use in Class II, heating or cooling applications.
- Low voltage terminal board with standard terminal designation for easy wiring.
- 16 gauge lead wires with quick-connect plug-in terminals provide wiring flexibility.
- Mounts on standard 4 x 4 junction box.

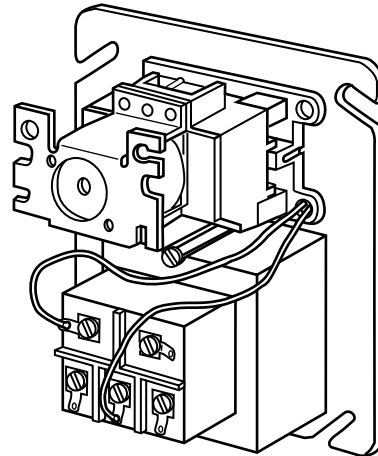

INSTALLATION

Turn off electrical power to heating and cooling systems. Record the positions and color codes of the leads on the existing relay. Also record all external wiring connections (line and low voltage).

Use the color-coded terminal leads installed on the new fan control center to duplicate the wiring of the existing control. Make sure all connecting points are the same for both relays.

NOTE

Lead wires connecting the low voltage relay coil to terminals "C" and "G" on the low voltage terminal panel are factory installed to prevent accidental connection to the line voltage circuit. When making line-voltage connections, be sure no connections are made to low-voltage control circuit.

Make all line voltage connections following the information recorded previously.

Mount the fan control center on the junction box.

Connect low voltage wiring to terminal board on fan control center following hookups recorded previously.

NOTE

Unused transformer input leads must be insulated.

Energize system and check for proper operation.



UL Recognized for US and Canada.
File Number E73641.

Model Number	Transformer						Relay	Contact Ratings			
	Primary			Secondary				120 VAC (amps)		240 VAC (amps)	
	Voltage	Hz	Connections	Voltage	VA	Connections		Full Load	Locked Rotor	Full Load	Locked Rotor
90-112	120	60	Color coded leads, pre-stripped	24V	40	Terminal board with 5 screw terminals	DPDT	13.8	82.8	6.9	41.4
90-113	120	60	Color coded leads, pre-stripped	24V	40	Terminal board with 5 screw terminals	SPDT	13.8	82.8	6.9	41.4
90-117	120	60	Color coded leads, pre-stripped	24V	40	Terminal board with 5 screw terminals	SPNO	13.8	82.8	6.9	41.4
90-118E	120	60	Color coded leads, pre-stripped	24V	40	Terminal board with 5 screw terminals	SPNO/SPNC	13.8	82.8	6.9	41.4
90-119	208/240	50/60	Color coded leads, pre-stripped	24V	40	Terminal board with 5 screw terminals	SPDT	13.8	82.8	6.9	41.4
90-130	120/208/240	50/60	Color coded leads, pre-stripped	24V	40	Terminal board with 5 screw terminals	DPDT	13.8	82.8	6.9	41.4

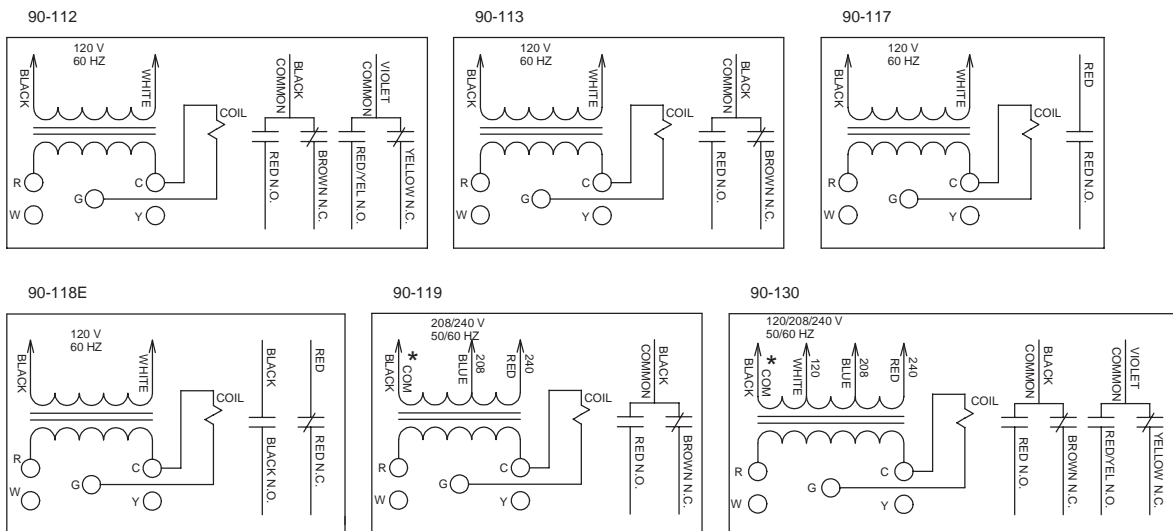

* Black is common with respect to transformer winding, not external circuit.