





# IEV22D

# IEV24D

**(release firmware 1.6)**

# INDEX

<b>1.</b>	<b>GENERAL WARNING</b>	<b>5</b>
1.1	 PLEASE READ BEFORE USING THIS MANUAL	5
1.2	 SAFETY PRECAUTIONS	5
1.3	PRODUCT DISPOSAL (WEEE)	6
<b>2.</b>	<b>MAIN CHARACTERISTIC</b>	<b>7</b>
<b>3.</b>	<b>USER INTERFACE</b>	<b>7</b>
3.1	ICONS OF THE DISPLAY	7
3.2	KEYS	8
3.3	SCREEN DISPLAY	9
3.4	VIEWING THE MEASURED OR CALCULATED VARIABLES	10
3.5	VIEWING ACTIVE ALARMS, ALARM LOG AND THE UPLOAD FUNCTION	12
3.6	VIEWING THE SUPERHEATING SET POINT	12
3.7	MODIFYING THE SUPERHEATING SET POINT	13
3.8	VIEWING PARAMETERS OF LEVEL PR1	13
3.9	VIEWING PARAMETERS OF LEVEL PR2	14
3.10	HOW TO MODIFY THE PARAMETERS	16
3.11	MODIFYING THE VALUE OF PASSWORD PR2	17
3.12	TEMPERATURE AND PRESSURE PARAMETER VALUES	19
<b>4.</b>	<b>CONNECTIONS</b>	<b>19</b>
<b>5.</b>	<b>DIGITAL INPUTS</b>	<b>21</b>
<b>6.</b>	<b>RELAY</b>	<b>22</b>
<b>7.</b>	<b>GENERAL DESCRIPTION</b>	<b>22</b>
7.1	KIND OF OPERATION	23
7.2	CONFIGURATION VALVE ↔ CIRCUIT	26
7.3	VALVE MANAGEMENT	27
7.4	ALARM MANAGEMENT	31
<b>8.</b>	<b>DESCRIPTION OF PARAMETERS</b>	<b>32</b>
8.1	PROBE CONFIGURATION PARAMETERS	32
8.2	PARAMETERS TO CONFIGURE THE RELAYS AND DIGITAL INPUTS	33
8.3	DISPLAY VIEW SETTING PARAMETERS	33
8.4	VALVE CONFIGURATION PARAMETERS	33
8.5	SYSTEM CONFIGURATION PARAMETERS	34
8.6	ADJUSTMENT PARAMETERS	34
8.7	OTHER PARAMETERS	36
<b>9.</b>	<b>PARAMETERS TABLE</b>	<b>37</b>
<b>10.</b>	<b>ALARM CODES AND ACTIONS</b>	<b>47</b>



<b>11.</b>	<b>PARAMETER PROGRAMMING KEY - HOTKEY 4K.....</b>	<b>49</b>
11.1	DOWNLOAD .....	50
11.2	UPLOAD .....	50
<b>12.</b>	<b>SERIAL OUTPUT .....</b>	<b>51</b>
<b>13.</b>	<b>MAXIMUM POWER ALLOWED.....</b>	<b>51</b>
<b>14.</b>	<b>INSTALLATION .....</b>	<b>52</b>
14.1	GENERAL RULES.....	52
14.2	ANALOGUE INPUT CONNECTION .....	53
14.3	SUPERCAP CONNECTION DIAGRAM.....	54
14.4	LAN CONNECTION .....	56
<b>15.</b>	<b>PLASTIC CONTAINER.....</b>	<b>57</b>
<b>16.</b>	<b>TECHNICAL SPECIFICATIONS .....</b>	<b>57</b>
16.1	ELECTRICAL SPECIFICATION .....	57
16.2	ANALOGUE INPUTS .....	58
16.3	DIGITAL INPUTS .....	58
16.4	RELAY OUTPUTS .....	58
16.5	OPERATING CONDITIONS .....	59

## 1. GENERAL WARNING

### 1.1 Please read before using this manual

- This manual is part of the product and should be kept near the instrument for easy and quick reference.
- The instrument shall not be used for purposes different from those described hereunder. It cannot be used as a safety device.
- Check the application limits before proceeding.
- Dixell Srl reserves the right to change the composition of its products, even without notice, ensuring the same and unchanged functionality.

### 1.2 Safety Precautions

- Do not expose the device to water or moisture: use the controller only within the operating limits avoiding sudden temperature changes with high atmospheric humidity (to prevent formation of condensates).
- Use the controller only within the operating limits (temperature, humidity, supply power, characteristics of the connected loads, etc.).
- Caution: Before beginning any maintenance operation, disconnect all electrical connections of the instrument
- The instrument must not be opened.
- In case of failure or faulty operation send the instrument back to the distributor or to "Dixell srl" (see address at the end of this document) with a detailed description of the fault.
- Pay attention to the maximum current applied to each relay (see section "Technical Data").
- Ensure that the wires of probes, power supply and power loads are separated and far enough from each other, without crossing or intertwining.
-  symbol is intended to alert the user to the presence of uninsulated "dangerous voltage" within the product area of sufficient magnitude to constitute a risk of electric shock to persons.
-  symbol is intended to alert the user to the presence of important operating and maintenance (servicing) instructions in the literature accompanying the device
- Dixell Srl reserves the right to modify this manual without notice.
- This manual is part of the product and should be kept near the equipment for its consultation.
- The device cannot be used as a safety device.
- The product should not be used in a different way as shown in the documentation.
- The device must always be placed inside a cabinet, accessible only by authorized personnel.

 Separate the power supply of the device from power supply of other electrical devices connected in the electrical panel (use separated transformer). The secondary of the transformer must not be connected to earth.

### 1.3 PRODUCT DISPOSAL (WEEE)

With reference to Directive 2002/96/EC of the European Parliament and of the Council of 27 January 2003 and to the relative national legislation, please note that:

- There lies the obligation not to dispose of electrical and electronic waste as municipal waste but to separate the waste.
- Public or private collection points must be used to dispose of the goods in accordance with local laws. Furthermore, at the end of the product's life, it is also possible to return this to the retailer when a new purchase is made.
- This equipment may contain hazardous substances. Improper use or incorrect disposal can have adverse effects on human health and the environment.
- The symbol shown on the product or the package indicates that the product has been placed on the market after 13 August 2005 and must be disposed of as separated waste.
- Should the product be disposed of incorrectly, sanctions may be applied as stipulated in applicable local regulations regarding waste disposal.

## 2. Main characteristic

IEV is an electronic controller designed for the management of one or two stepper motors (unipolar or bipolar) of electronic expansion valves .

IEV is available with a single driver for use with single gas circuit (IEV22D) or double drivers for applications in two gas circuits (IEV24D).

IEV is compatible with several types of refrigerant and the main valves available in the market.

Two different regulation are available:

- STAND ALONE: the digital inputs are used to start the superheat control. Evaporating pressure transducer and suction temperature probe has to be connected to the IEV;
- LAN: the IEV can be connected to the I chill 200 EVO series to control the machine (chiller or heat pump) and the superheat.

Evaporating temperature probe has to be connected to the IEV and suction pressure transducer can be connected to the IEV or to the I chill (by configuring dedicated parameters).

To guarantee the best regulation is recommended to connect the suction pressure transducer directly to the IEV.





Main features:

- management of one or two electronic expansion valves
- compatibility with several models of valve
- compatibility with different types of refrigerant gas
- manual control of PID regulation or adaptive regulation
- digital inputs to start regulation in STD\_ALONE configuration
- LAN connection with IC 200 EVO family controllers
- double- digit display for simultaneous multiple information

## 3. User interface





### 3.1 Icons of the display

°C -°F BAR-PSI	ON when the displays show a temperature or pressure.
	ON in parameter programming if the displays show temperature or pressure set points/differentials.
%	ON when the displays show the opening percentage of one of the two valves.
 	ON when the valve is activated for adjustment. Both can be ON if both valves are in adjustment mode.
V1 V2	ON when the display shows the temperature/pressure/superheating of valve 1 or valve 2 (valve selection via  ).
	ON and flashing if the valve is closing or opening. Remains ON if the valve is in a static position.
open	ON if the valve is opening.
close	ON if the valve is closing.
	ON and flashing if an alarm is active.
menu	ON if the menu appears.

### 3.2 Keys



	Press the key to toggle between the information of valve 1 and valve 2.
SET	Press the key to view the superheating set point. The superheating set point can be modified by pressing the key for 4 seconds.



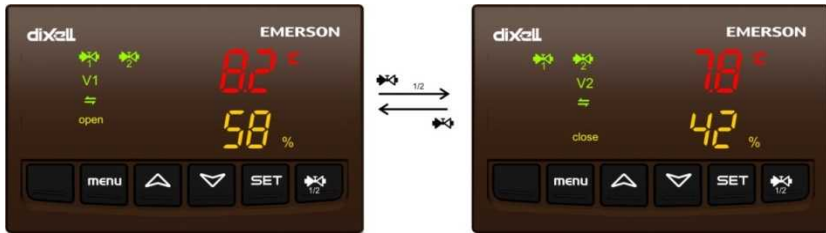

	<p>Press the keys to:</p> <ul style="list-style-type: none"> <li>• scroll through the suction temperature, the evaporation pressure, the superheating value, etc.</li> <li>• scroll through the parameters and increase/decrease the value of the parameters being modified</li> <li>• toggle between the items while browsing the menu</li> </ul>
<p><b>menu</b></p>	<p>Press this key to access the menu to view the active alarms.</p>
<p><b>SET +</b> </p>	<p>Press the keys simultaneously for 4 seconds to access the parameter programming area.</p>
<p><b>SET +</b> </p>	<p>Press the keys simultaneously to exit from the parameter programming area.</p>





### 3.3 Screen display



The variables (suction temperature, evaporation pressure, superheating value, opening value of the valve, etc.) that are to be viewed on the upper and lower displays are selected via the special parameter (Ec43 and Ec44).

Press the  key to view the variables (suction temperature, evaporation pressure, superheating value, etc.) of valve 1 or valve 2. The   icons, which represent the state of the valve (icon ON if the valve is adjusting), are always displayed, even if the currently displayed variables are those of the other valve.

If the variables of valve 1 are shown on the display, only the icons belonging to valve 1 are viewed (V1, , , except for the status icon ( ).

If the variables of valve 2 are shown on the display, only the icons belonging to valve 2 are viewed (V2, , , except for the status icon ( ).

The alarms are shown in the lower display, regardless whether they belong to valve 1 or 2. The alarms are shown alternately with the value that appears in the lower display under normal conditions. If the probe that is to be displayed is in error, "----" appears instead of the value.

#### Other parameters involved on visualization/configuration





**Ec41** Unit of measure (°C / bar ÷ °F / psi)

**Ec42** Pressure measurement (0=relative, 1= absolute)

**Ec45** Opening percentage visualization (0=no, 1=yes)

### 3.4 Viewing the measured or calculated variables

Press the   keys to view the values of the following measured and calculated variables concerning valve 1 or 2:

- Superheating set point (SHC / SHH)
- Superheating value (SH)
- Valve opening (OPEn)
- Suction temperature (SCt1)
- Evaporation pressure (LP1)
- Evaporation temperature (tP1)
- Operation mode (Cool / HEAt)
- Adjustment method (Man – AUto)

Press the  key to select whether to view the variables of probe 1 or probe 2.

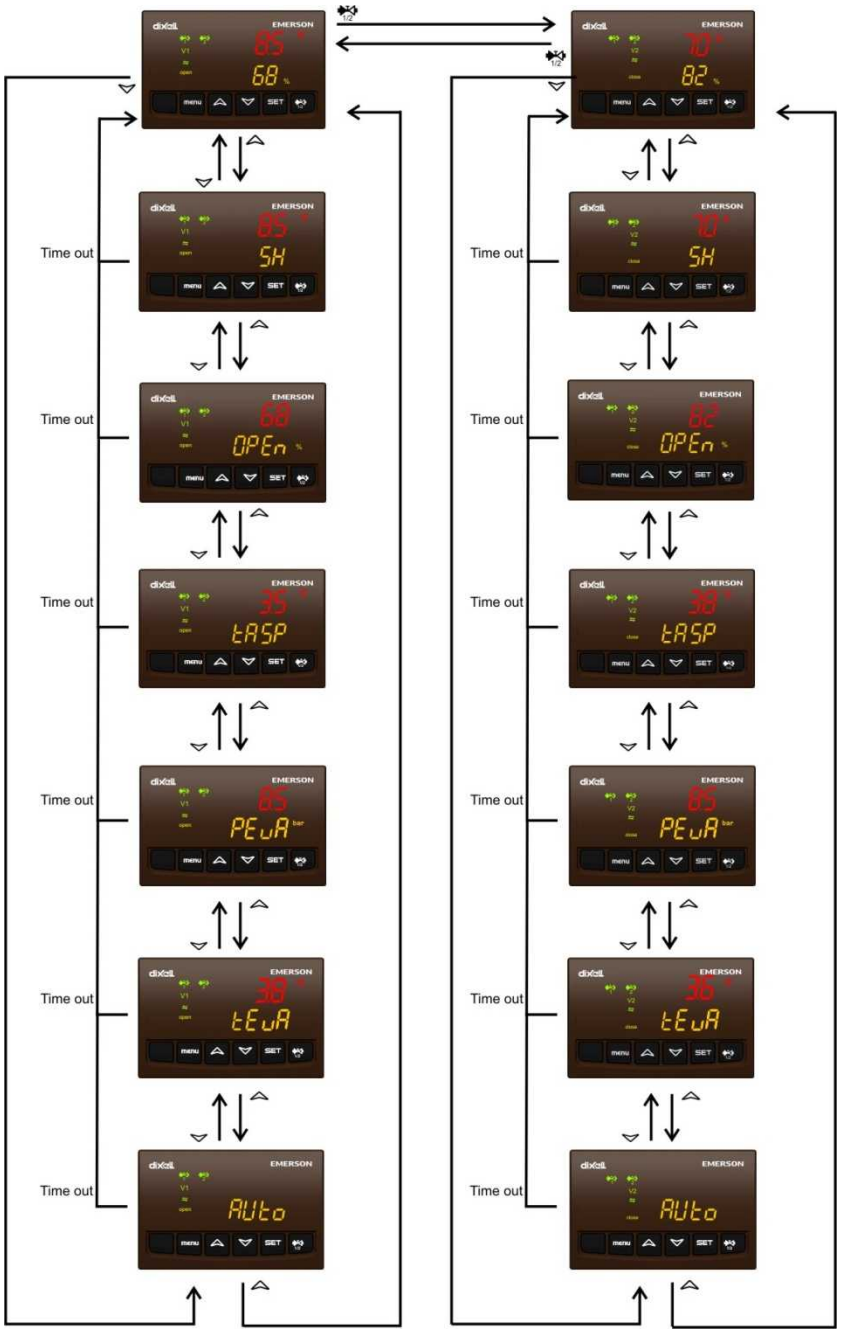

### 3.5 Viewing active alarms, alarm log and the upload function

The following can be viewed by pressing the “menu” key:

- ALrM: active alarms (if present); press  $\blacktriangle$   $\blacktriangledown$  to view all the other alarms
- ALoG: alarm log (last 50 alarms with fifo logic)
- UPL: menu to upload the map of parameters (copy the map from HotKey 4K to IEV)

After viewing the last alarm in the ALoG menu, ArSt appears on the lower display and PAS on the upper display. The Alarm log is reset by logging in via the password (default value = 4).

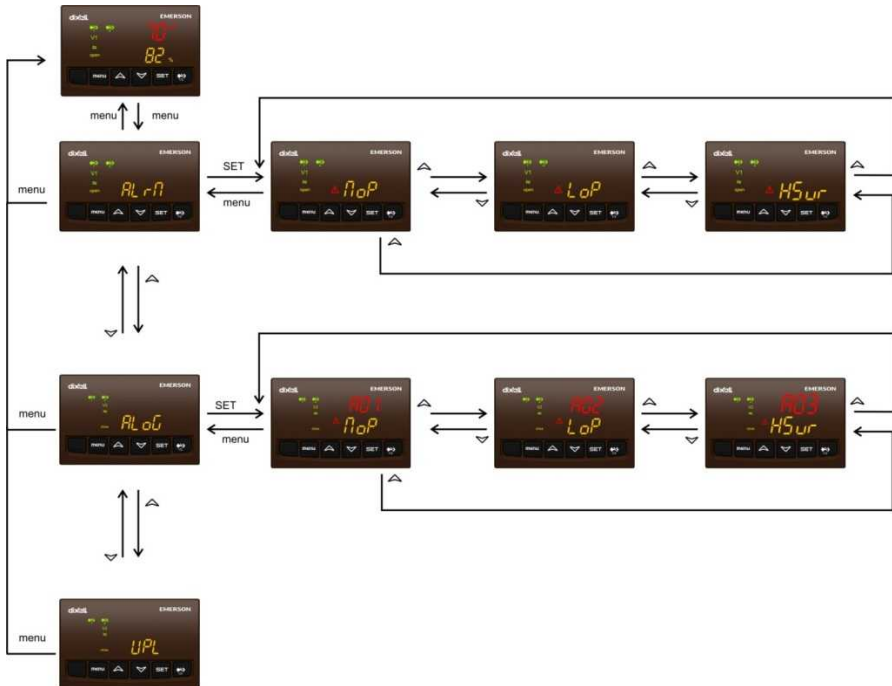

### 3.6 Viewing the superheating set point

Pushing SET key it will be visualized superheating cooling set point (SHC) or heating set point (SHH), depending on operation mode at the time.

If the device is configured for both operation mode, in STD-BY the display shows both set point.



### 3.7 Modifying the superheating set point

Proceed as follows to modify the superheating set point:

- press **SET** for 5 seconds
- the superheating set point of valve 1 flashes
- press **▲ ▼** to modify the superheating set point
- press **SET** to confirm the value
- the superheating set point of valve 2 (if present) flashes
- press **▲ ▼** to modify the superheating set point
- press **SET** to confirm the value and return to the normal display



### 3.8 Viewing Parameters of level Pr1

Proceed as follows to view the parameters:

- press **SET** and simultaneously for 5 seconds **▼**
- press **▲ ▼** to view the desired parameter
- press **SET** and **▲** simultaneously to exit from viewing the parameters

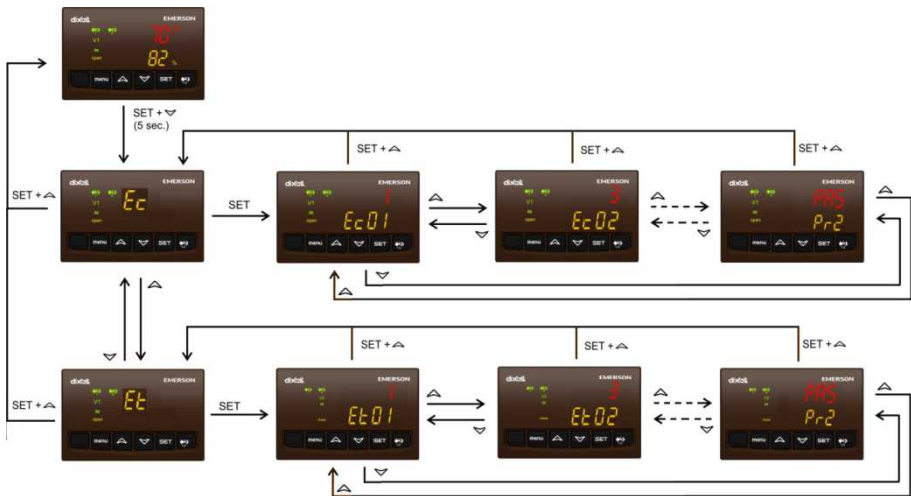

### 3.9 Viewing Parameters of level Pr2

Proceed as follows to view the parameters:

- press **SET** and simultaneously for 5 seconds  $\nabla$
- press  $\Delta$   $\nabla$  to view the password Pr2 parameter (last parameter on the list)
- press **SET**
- press  $\Delta$   $\nabla$  to enter the value of password Pr2
- press **SET**
- the first parameter of the list will appear on the display; from this moment onwards, all the parameters visible in Pr1 and Pr2 will be displayed

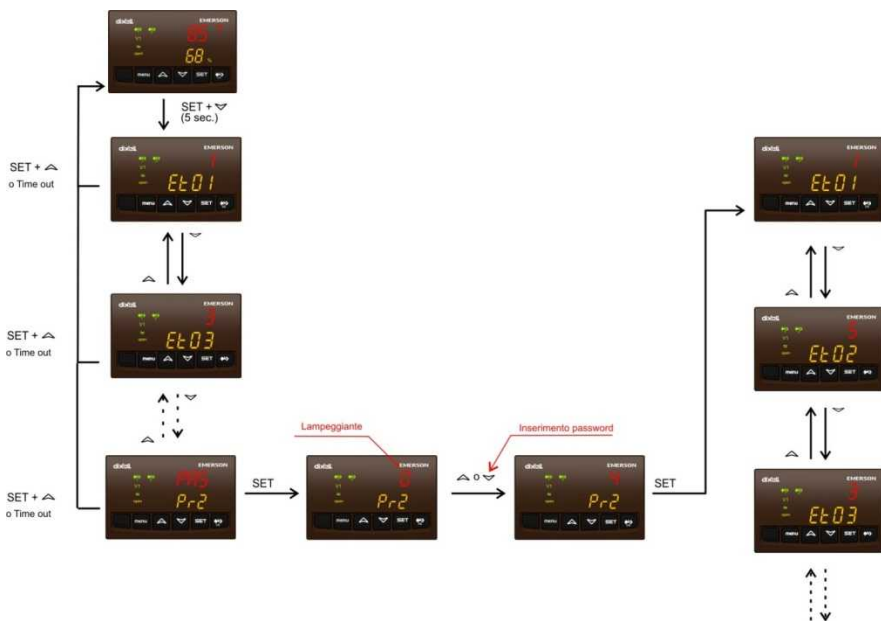

## How to modify visibility level

To modify the visibility lev of a parameter from Pr1 to Pr2 or from Pr2 to Pr1 is necessary:

- enter programming parameters level Pr2
- select the parameter
- push SET key and hold it down then press **▼** key
- if the dot point on parameter label is lighted, it means that the parameter is visible also in Pr1 visibility level
- repeat above procedure to make the parameter visible or not in Pr1 level

### Parametro visibile anche in Pr1



### Parametro visibile in Pr2



#### 3.10 How to modify the parameters

Proceed as follows to access the programming area of the parameters displayed in Pr1:

- press **SET** and simultaneously for 5 seconds  $\nabla$
- press  $\blacktriangle$   $\nabla$  to view the parameter that is to be modified
- press **SET**
- press  $\blacktriangle$   $\nabla$  to modify the value of the parameter
- press **SET** to confirm the value and move on to the next parameter
- repeat the above steps to modify the other parameters
- press **SET and**  $\blacktriangle$  simultaneously to exit from the programming area of the parameters

Proceed as follows to access the programming area of the parameters displayed in Pr2:

- press **SET** and simultaneously for 5 seconds  $\nabla$
- press  $\blacktriangle$   $\nabla$  to view the password Pr2 parameter (last parameter on the list)
- press **SET**
- press  $\blacktriangle$   $\nabla$  to enter the value of the current password
- press **SET** to confirm the value
- parameter Et01 will be displayed once again (in this case the parameters of level Pr2 are displayed)
- press  $\blacktriangle$   $\nabla$  to view the desired parameter
- press **SET** if the parameter must be modified
- press  $\blacktriangle$   $\nabla$  to enter the new value
- press **SET** to confirm the value
- press **SET and**  $\blacktriangle$  simultaneously to exit from the programming area of the parameters

## Modifying the parameters displayed in Pr1:

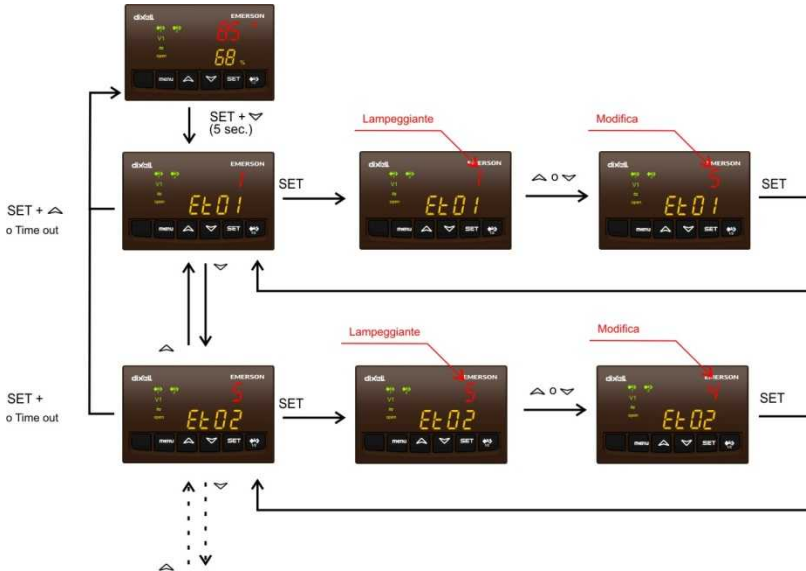

### 3.11 Modifying the value of Password Pr2

Proceed as follows to edit the value of the password:

- press **SET** and simultaneously for 5 seconds  $\nabla$
- press  $\nabla$   $\nabla$  to view the password Pr2 parameter (last parameter on the list)
- press **SET**
- press  $\nabla$   $\nabla$  to enter the value of the current password
- press **SET** to confirm the value
- parameter Et01 will be displayed once again (in this case the parameters of level Pr2 are displayed)
- press  $\nabla$   $\nabla$  to view the password Pr2 parameter (last parameter on the list)
- press **SET**
- press  $\nabla$   $\nabla$  to enter the new value of the password
- press **SET** to confirm the value
- press **SET and**  $\nabla$  simultaneously to exit from the programming area of the parameters



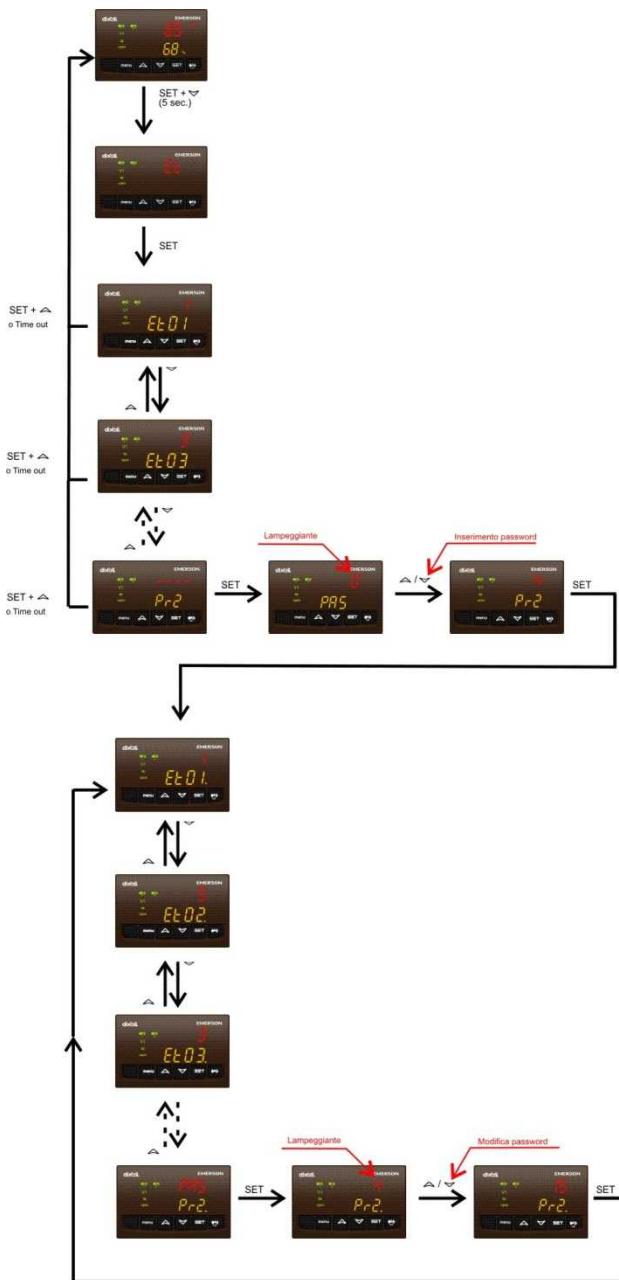

### 3.12 Temperature and Pressure Parameter Values

All parameters that indicate a temperature or pressure can be expressed in degrees Celsius/bar or Fahrenheit/PSI, according to parameter Ec41 that sets the unit of measurement.

Modifying the Ec41 parameter from Celsius/bar to Fahrenheit/PSI and vice versa **does not involve an automatic update** of the parameters from one unit of measurement to the other. Therefore, the operator must check all the parameters concerning temperature and pressure in order to modify them accordingly.

In particular, by modifying the Ec41 parameter from °C/bar to °F/PSI:

- the value of the temperature and pressure parameters are multiplied by 10 (with no decimal).

Modifying the Ec41 parameter from °F/PSI to °C/bar:

- the value of the temperature and pressure parameters are divided by 10 (with a decimal).

**When the instrument is switched on, the parameters are verified and modified if they are out of the specified range of values.**

## 4. Connections

Power connections, probes, digital inputs and relay outputs



## Multipolar connector

Terminal	Type	Description
1	Supply	AC supply: 24Vac DC supply: Reference "+" 24 Vdc
2	Pb1	Analogue input 1 (NTC, PTC, PT1000)
3	Pb2	Analogue input 2 (NTC, PTC, PT1000)
4	Pb3	Analogue input 3 (NTC, PTC, PT1000, 0 - 5V, 4 - 20 mA)
5	Pb4	Analogue input 4 (NTC, PTC, PT1000, 0 - 5V, 4 - 20 mA)
6	LAN +	LAN Connection (+ terminal) to connect to IC200 EVO series
7	Supply	AC supply: 24Vac DC supply: Reference "-" 24 Vdc
8	Pbc	Analogue inputs common line
9	+12V	Voltage output +12Vdc (to connect current trasducers)
10	GND	Ground (to connect rathimetric probe)
11	+5V	Voltage output +5Vdc (to connect rathimetric probe)
12	LAN -	LAN Connection (- terminal) to connect to IC200 EVO series

## Digital input connector

Terminal	Type	Description
28	DI1	Digital input 1
29	C	Common digital inputs
30	DI2	Digital input 2
31	DI3	Digital input 3
32	C	Common digital inputs
33	DI4	Digital input 4

## Serial output RS485 and relays output

Terminal	Type	Description
17	RS485 +	RS485 Connection (+ terminal)
18	RS485 -	RS485 Connection (- terminal)
19	C	Common relay 1
20	RL1	Relay 1
21	C	Common relay 2
22	RL2	Relay 2

## Supercap connector

41	+In	Input from XEC Supercap
42	gnd	Ground XEC Supercap

## HotKey 4K connector

This connector is used to connect the HotKey to upload or download the configuration parameters.

## Valve connector

Set the programming of the configuration parameters before connecting the valve; the connection of a valve with features not compatible with the model set in the device can result in a failure of the device or to the valve

Do not connect or disconnect the valve while the device is connected to the power; this operation may result in the breakdown of the device

## Connector Valve 1

### Valve 1 connections

Terminal	Type	Description
5	+12V	Voltage output +12Vdc
1	W1	Connection to valve 1 (first coil)
3	W1	Connection to valve 1 (first coil)
2	W2	Connection to valve 1 (second coil)
4	W2	Connection to valve 1 (second coil)

### Valve 2 connections

Terminal	Type	Description
5	+12V	Voltage output +12Vdc
1	W1	Connection to valve 2 (first coil)
3	W1	Connection to valve 2 (first coil)
2	W2	Connection to valve 2 (second coil)
4	W2	Connection to valve 2 (second coil)

## 5. Digital inputs

The device has 4 digital inputs that can be configured via parameters that involve the following functions:

0 : not configured

o1 : call to adjust circuit 1 - active by an open contact

- c1 : call to adjust circuit 1 - active by a closed contact
- o2 : circuit 1 cooling/heating function - active by an open contact
- c2 : circuit 1 cooling/heating function - active by a closed contact
- o3 : circuit 1 defrosting - active by an open contact
- c3 : circuit 1 defrosting - active by a closed contact
- o4 : call to adjust circuit 2 - active by an open contact
- c4 : call to adjust circuit 2 - active by a closed contact
- o5 : circuit 2 cooling/heating function - active by an open contact
- c5 : circuit 2 cooling/heating function - active by a closed contact
- o6 : circuit 2 defrosting - active by an open contact
- c6 : circuit 2 defrosting - active by a closed contact

Only when the device is running in Std-alone mode, are the functions of the digital inputs considered.

## 6. Relay

The device has 2 relays for alarm signalling, that can be configured via parameters Ec35 and Ec36 with following functions:

- 0= not configured
- 1= actives for probe alarm circuit 1
- 2= actives for MOP, LOP and probe alarm circuit 1
- 3= actives for high superheating, low superheating and probe alarm circuit 1
- 4= actives for high superheating, low superheating, MOP, LOP and probe alarm circuit 1
- 5= actives for probe alarm circuit 2
- 6= actives for MOP, LOP and probe alarm circuit 2
- 7= actives for high superheating, low superheating and probe alarm circuit 2
- 8= actives for high superheating, low superheating, MOP, LOP and probe alarm circuit 2

## 7. General description

There are 2 different configurations of IEV device:

- **Ec1=0 Std-alone operation mode**  
This operation mode adjusts the superheating according to the reading of the evaporation pressure and suction temperature. 4 digital inputs are available to enable the adjustment and to select the summer or winter mode.
- **Ec1=1 LAN operation mode**  
This operation mode can only be used in conjunction with an Ichill 200 EVO controller. The superheating is adjusted according to the reading of the evaporation pressure and the suction temperature and the Ichill provides information concerning the status of the machine via the LAN to the valve, which will be used by the valve for the adjustment.

The adjustment of the IEV valve driver is based on the superheating value, which is calculated as the difference between the temperature of the superheated gas (**Ta**), measured by the temperature probe, and the evaporation temperature (**Tb**), measured by the evaporation transducer and subsequently converted into temperature using the tables of the relative gas.

$$SH = Ta - Tb$$

A high superheating value means that the gas flow passing in the evaporator is insufficient and the evaporation process ends before reaching the end of the evaporator. The valve must be opened to increase the gas flow.

A low superheating value means that the gas flow passing in the evaporator is excessive and the evaporation process does not end before reaching the end of the evaporator. The valve must be closed to reduce the gas flow.

Parameters Ec6 and Ec7 configure the association of valves 1 e 2 with a cooling circuit:

- 0 – not present
- 1 – circuit 1
- 2 – circuit 2

Use parameters Ec4 and Ec5 to selecting operating mode of the valves, which can be:

- 0 – summer mode only (chiller)
- 1 – winter mode only (heat pump)
- 2 – summer and winter mode (chiller and heat pump)

Note:

In *std-alone* mode, if no digital input is configured to select the summer / winter operating mode:

- in case of a circuit with one valve:

- If the valve is set to operate in summer mode only (Ec4 =0 /Ec5 =0), the adjustment will take place in this mode
- If the valve is set to operate in heating mode only (Ec4 =1 /Ec5 =1), the adjustment will take place in this mode
- If the valve is set to operate in summer and winter mode only (Ec4 =2 /Ec5 =2), this will generate a configuration error

- in the event of a circuit with two valves, this will generate a *configuration error*

## 7.1 Kind of operation

One can determine whether the calculation of the aperture value of the valve is calculated by the regulator based on the PID parameters entered manually in the parameter map or automatically (self-adaptive function) by the device:

- by setting parameters Et7 and Et27 with a value other than 0, the adjustment is carried out by considering the PID parameters entered in the parameters map
- by setting parameters Et7 and Et27 to 0, the adjustment is automatically carried out by the controller, which autonomously calculates the aperture of the valve based on a number of parameters

The auto-adaptive operation is only recommended in cases where the machine operates mainly in terms of stability, in which the automatic adjustment can reach the optimum setting; in heat pumps, machines in which the change of operation mode (heating, cooling, domestic hot water, defrost), the optimum adjustment is achieved by manually setting the PID parameters.

In PID control, it is advisable to adjust the parameters PI leaving the derivative D to the value 0; the setting of this parameter is not simple and its variation has important effects on the regulation.

### 7.1.1 **Manual mode**

If manual mode has been selected (par. Et2/Et5), the controller will bring the valve to the number of steps set in parameter Et3/Et6 while remaining in that position; opening and/or closing valve are not active.

This can be helpful during the set-up of the machine or in case of maintenance.

### 7.1.2 **Adjustment mode**

Only at start-up, regardless of the mode of operation, the valve will be completely closed by reaching the maximum number of steps of the Ec13/Ec22 valve plus the extra steps for the complete closure Ec11/Ec20.

Once it is closed completely, it will go to the adjustment position by performing the relaxation steps Ec12/Ec21 while opening.

When the driver valve starts to regulate the valve moves to the number of steps set by Et1 / Et4 and remains there for the time Et23 / Et43.

PID parameters for summer and winter operation mode must be configured by the user and adapted in function of the type of machine and plant.

### 7.1.3 **Defrost**

The adjustment in defrost mode is carried out like the adjustment in cooling mode, but the proportional constant is determined by the specific Et51 parameter.

In the event of a circuit with two valves, one configured to only operate in heat pump mode and one configured only operate in chiller mode, defrost is carried out with the valve configured for the chiller mode.

In the event of a circuit with just one valve that operates in chiller and heat pump mode, the valve will also carry out the defrost.

If the valve(s) are set for operation in heat pump mode only, the defrost valves will not be activated.

### **Valve connected via LAN to Ichill – EVO series**

- Defrost input
  - Ichill turns off the compressor(s) before reversing the gas cycle
    - when Ichill turns off circuit's compressors to perform the defrost, the valve closes.
    - when Ichill requests the switch-on of the compressors after reversing the gas cycle to perform the defrost. The valve opens at the step number set under parameter Et52 / Et54 and maintains this position for the time set under Et53 / Et55 before providing the consent to Ichill to turn on the compressor(s) for the defrost stage
    - after the Et53 / Et55 pre-aperture time, the valve provides adjustments according to the chiller mode, though the proportional component is provided by the specific Et51 defrost parameter
  - Ichill does not turn off the compressor(s) before reversing the gas cycle

- when Ichill transmits the defrost status to the valve (i.e. when it reverses the gas cycle), the valve starts adjusting according to the chiller mode, though the proportional component is provided by the specific Et51 defrost parameter
    - during the initial stage, during the Et53 / Et55 time calculated from when the defrost starts, if the adjustment of the valve requires an aperture value below the step number set under parameter Et52 / Et54, the valve will not close at a value below Et52 / Et54 (which is therefore the minimum aperture threshold in the initial defrost stage). Once the Et53 / Et55 time has elapsed, the adjustment will go ahead as it normally does for defrost.
- Defrost output
  - Ichill turns off the compressor(s) before reversing the gas cycle and going back to heating mode (heat pump)
    - when Ichill turns off the compressors after completing the defrost, the valve closes
    - when Ichill requests the switch-on of the compressors for the input undergoing adjustment in heating mode (heat pump), the valve opens at the step number set under parameter Et1 / Et4 and maintains this position for the time set under Et43 before providing the consent to Ichill to turn on the compressors
    - once the Et43 pre-aperture time has elapsed, the valve performs adjustments in accordance with the heating mode (heat pump)
  - Ichill does not turn off the compressor(s) to go back to heating mode (heat pump)
    - when Ichill completes the defrost stage and switches to adjustment in heating mode (heat pump), the valve maintains the step number it currently has for the time set under the Et43 parameter
    - once the Et43 time has elapsed, the valve performs adjustments in accordance with the heating mode (heat pump)

### Valve used in STD-ALONE mode

The activation of the digital defrost input is only effective if the adjustment request digital input is already active.

In STD-ALONE mode, the IEV does not carry out any check on the operating status of the chiller or the heat pump; if the digital defrost request input is active, the IEV will set itself to the defrost adjustment mode regardless of the active operating status at the time.

- Defrost input
  - The digital defrost input is activated by maintaining the adjustment request active
    - When the digital defrost request input is activated, the valve starts adjusting according to the chiller mode, though the proportional component is provided by the specific Et51 defrost parameter





or by the digital input		
Summer mode	Chiller only	Valve adjusts in chiller mode
	Heat pump only	Valve does not adjust - Function is disabled
	Chiller and heat pump	Valve adjusts in chiller mode
Winter mode	Chiller only	Valve does not adjust - Function is disabled
	Heat pump only	Valve adjusts in heat pump mode
	Chiller and heat pump	Valve adjusts in heat pump mode

### Configuration with two valves associated with a circuit

Available configurations:

- valve 1 and valve 2 associated with circuit 1
- valve 1 and valve 2 associated with circuit 2

**In this case the two valves will never operate simultaneously.**

Mode established by the controller connected via LAN or by the digital input	Configuration of <b>Valve 1</b> (parameter Ec4)	Configuration of <b>Valve 2</b> (parameter Ec5)	
Summer mode	Chiller only	Chiller	ACF1 Configuration Error
		Heat pump	Valve 1 adjusts in Chiller mode
		Chiller / heat pump	ACF1 Configuration Error
	Heat pump only	Chiller	Valve 2 adjusts in Chiller mode
		Heat pump	ACF1 Configuration Error
		Chiller / heat pump	ACF1 Configuration Error
	Chiller / heat pump	Chiller	ACF1 Configuration Error
		Heat pump	ACF1 Configuration Error
		Chiller / heat pump	ACF1 Configuration Error
Winter mode	Chiller only	Chiller	ACF1 Configuration Error
		Heat pump	Valve 2 adjusts in Heat pump mode
		Chiller / heat pump	ACF1 Configuration Error
	Heat pump only	Chiller	Valve 1 adjusts in Heat pump mode
		Heat pump	ACF1 Configuration Error
		Chiller / heat pump	ACF1 Configuration Error
	Chiller / heat pump	Chiller	ACF1 Configuration Error
		Heat pump	ACF1 Configuration Error
		Chiller / heat pump	ACF1 Configuration Error

## 7.3 Valve management

The opening or closing of the valve is carried out by the actuation of a stepper motor.

The device can manage both unipolar and bipolar valves (if there are two configured valves, they must be the same type of valve, unipolar or bipolar); the type of valve is selected via parameter Ec3.

The unipolar valve is moves by provided current impulses to the 4 phases of the valve's motor. The movement takes place for "HALF A STEP". Make sure that the technical documentation of the valve you need to use mentions control by half a step, otherwise this will result in an incorrect control of the valve). An impulse is provided on one or two phases in the suitable sequence based on the direction of rotation of the motor (aperture or closure).

The parameters related to the number of steps (maximum number of regulating steps, minimum number of regulating steps, maximum number of steps per second, etc.) are common to both valves type, unipolar and bipolar, and they are expressed in full steps; during setting phase, it is therefore necessary to pay attention that, for example, if the technical documentation of the valve declares the number of steps per second = 90 half steps, the value to be written in the corresponding parameter is 45 full steps per second.

Please, make attention that the reference documentation for the configuration of these parameters is the technical documentation of the valve, in which must be specified if the data relating to the steps are expressed in full steps or half steps.

The movement of the bipolar valve takes place by providing current micro impulses to the valve's motor. When the valve is stopped because it has reached the optimum position, the current is reduced (if the function is enabled) in order to limit consumption and to prevent excessive overheating. The "holding" current is defined by parameter **Ec16 / Ec25**.

### **7.3.1 Valve selection**

If the valve is the unipolar type, all relevant parameters must be set manually.

If the valve is the bipolar type it is possible to select, using the parameters EC9 / EC18, one of the pre-configured valves.

If the valve to be used is not available on the list, you must manually set the parameters shown in the table below using the data available in the documentation of the valve; in this case the parameters EC9 / EC18 must be set to 0 value.



#### **Attention**

**The IEV driver has stored the data of some valves available on the market; due to errors in the valves documentation or updates made by the manufacturer, the data may change over time. It is necessary to check the updated data before using the valve driver IEV; if the data of the valve have been modified by the manufacturer or if the data reported in the technical documentation are different from those shown in the table below, the parameters of the valve must be set manually.**

## Data of pre-configured valves

Parameter Ec9/Ec18	Model	Ec14 / Ec23 (steps *10)	Ec13 / Ec22 (steps*10)	Ec15 / Ec24 (mA*10)	Ec16 / Ec25 (mA*10)	Ec50 /Ec52	Ec51/ Ec53
0	Manual setting	Config	Config.	Config.	Config.	Config.	Config.
1	Danfoss ETS-25/50	0	2625	10	10	1	1
2	Danfoss ETS-100	0	3530	10	10	1	1
3	Danfoss ETS-250/400	0	3810	10	10	1	1
4	Sporlan SEI 0.5-11	0	1596	16	0	1	1
5	Sporlan SER 1.5-20	0	1596	12	0	1	1
6	Sporlan SEI 30	0	3193	16	0	1	1
7	Sporlan SER(I) G,J,K	0	2500	12	0	1	1
8	Sporlan SEI 50	0	6386	16	0	1	1
9	Sporlan SEH(I) 100	0	6386	16	0	1	1
10	Sporlan SEH(I) 175	0	6386	16	0	1	1
11	Alco EX4-EX5-EX6	0	750	50	10	1	1
12	Alco EX7	0	1600	75	25	1	1
13	Alco EX8 500	0	2600	80	50	1	1
14	Configuration 1	50	480	45	10	0	0
15	Configuration 2	50	380	45	10	0	0

### 7.3.2 Parameters to set in the event of manual configuration of the valve

#### Ec13/Ec22 maximum number of steps of valve

Refer to the technical documentation of the valve to set this parameter correctly.  
(this value is set automatically by the controller if EC9> 0 and / or EC18> 0)

#### Ec14/Ec23 Minimum number of valve steps

Refer to the technical documentation of the valve to set this parameter correctly.  
(this value is set automatically by the controller if EC9> 0 and / or EC18> 0)

### **Ec15/Ec24 maximum movement current**

Refer to the technical documentation of the valve to set this parameter correctly.  
(this value is set automatically by the controller if EC9> 0 and / or EC18> 0)

### **Ec16/Ec25 Holding current value**

Refer to the technical documentation of the valve to set this parameter correctly.  
(this value is set automatically by the controller if EC9> 0 and / or EC18> 0)

### **Ec50/Ec52 Setting of the kind of movement current**

Valve manufacturers use different ways of controlling them; parameters Ec50/Ec52 are used to establish whether the movement current value is a peak value or an RMS value in MICROSTEPPING ADJUSTMENT mode.

Refer to the technical documentation of the valve to set these parameters correctly.

Ec50/Ec52                      Setting of the movement current (peak or RMS)  
   0= peak current  
   1= RMS current

(this value is set automatically by the controller if EC9> 0 and / or EC18> 0)

### **Ec51/Ec53 Setting of the microstepping or normal mode adjustment**

Valve manufacturers use different ways of controlling them; parameters Ec51/Ec53 are used to establish whether the adjustment is a microstepping or normal mode one.

Refer to the technical documentation of the valve to set these parameters correctly.

Ec51/Ec53                      Microstepping or normal mode adjustment  
   0= microstepping  
   1= normal mode

(this value is set automatically by the controller if EC9> 0 and / or EC18> 0)

### **7.3.3 How to connect the valve**

Observe the table below for quick reference to the connection mode of valves deriving from different manufacturers:



#### **NOTE:**

- **Do not connect or disconnect the valve while the device is connected to the power; this operation may result in the breakdown of the device**
- **Set the programming of the configuration parameters before connecting the valve; the connection of a valve with features not compatible with the model set in the device can result in a failure of the device or to the valve**

- Carefully read the technical manual supplied by the manufacturer of the valve before using the driver in order to prevent changing the data, and verify that the declared colours comply with those in the table below.

#### 4-WIRE VALVES (BIPOLAR)

Terminal number	ALCO EX5/6/7/8	SPORLAN SEI-SHE	DANFOSS ETS
4	BLUE	WHITE	BLACK
2	BROWN	BLACK	WHITE
3	BLACK	RED	RED
1	WHITE	GREEN	GREEN
5 - Common	----	----	----

#### 5-WIRE VALVES (UNIPOLAR)

Terminal number	SPORLAN
4	ORANGE
2	RED
3	YELLOW
1	BLACK
5 - Common	GREY

The maximum distance between an IEV valve driver and the valve **must not exceed 10 metres**. Shielded cables with a section greater than or equal to 0.325 mm<sup>2</sup> (AWG22) must be used.

### 7.4 Alarm management

#### High superheating alarm

The high superheating alarm is generated when the calculated superheating is higher or equal to **Et12/Et32** for the Et49 time.

In the event of an alarm, the driver sets the valve to the maximum aperture.

The alarm is cleared when the superheating is less or equal to **Et12/Et32 – 1.0°C**.

#### Low superheating alarm

The low superheating alarm is generated when the superheating temperature is equal or less than **Et13/Et33** for the Et50 time.

In the event of an alarm, the driver sets the valve to the minimum aperture (Et20 / Et40).

The low superheating alarm is cleared when the superheating temperature is higher or equal to **Et13/Et33 + 1.0°**

#### Maximum MOP operating pressure alarm

The MOP alarm threshold is expressed as a temperature value and is equal to the pressure of probe 3 and probe 4 converted into a temperature value.

The MOP alarm is triggered when the equivalent temperature of the pressure probe exceeds Et15/Et35 for the Et48 time.

If the MOP alarm is still active, any low and high superheating alarms are reset.

When the alarm is active, the drive closes the valve by Et16/Et36 steps at each second of operation.

If the equivalent temperature of the pressure probe drops below Et15/Et35 - 1.0°C, the driver carries out the aperture of the valve by Et16/Et36 steps at each second of operation.

The alarm is cleared only when the superheating temperature drops below the superheating setpoint value.

### **Minimum LOP operating pressure alarm**

The LOP alarm threshold is expressed as a temperature value and is equal to the pressure of probe 3 and probe 4 converted into a temperature value.

The LOP alarm is triggered when the equivalent temperature of the pressure probe drops below Et17/Et37 for the Et47 time.

If the LOP alarm is still active, any low and high superheating alarms are reset.

When the alarm is active, the driver opens the valve by Et16/Et36 steps at each second of operation.

The condition to come out from minimum operating pressure are:

- the equivalent temperature of the pressure probe exceeds Et17/Et37 + 4.0°C
- Et17 < Evaporation pressure converted to temperature < Et17+4°C and superheating < Et13 (low superheating set point)

After LOP alarm reset, the driver carries out the aperture of the valve by Et16/Et36 steps at each second of operation

## **8. Description of parameters**

### **8.1 Probe configuration parameters**

- **Ec2** Positioning of the low pressure probe
  - If the IEV is configured in STD-ALONE mode, the low pressure probe must be configured in the IEV
  - If the IEV is configured with operation in LAN with the Ichill 200 EVO series, the low pressure probe can be configured in the IEV or in the Ichill; is strongly recommend the connection to the IEV as the pressure is calculated with the resolution in hundredths and is more accurate for the calculations carried out by the IEV
- **Ec27** Configuration of probes Pb1 and Pb2  
Used to select the kind of Pb1 and Pb2 probes (NTC, PTC, PT1000)
- **Ec28** Configuration of probes Pb3 and Pb4  
Used to select the kind of Pb3 and Pb4 probes (NTC, PTC, PT1000 , 4..20mA, 0..5V)

- **Ec29** Probe pressure value with suction at 4mA / 0.5V  
Used to set the minimum pressure value at 4mA / 0.5V, to be set based on the features of the transducer employed.
- **Ec30** Probe pressure value with suction at 20mA / 4.5V  
Used to set the maximum pressure value at 20mA / 4.5V, to be set based on the features of the transducer employed.
- **Ec31...Ec34** Calibration of probes Pb1...Pb4  
Used to calibrate probe reading to correct any measuring errors
- **Ec41** Unit of measurement selection  
Used to select the unit of measurement °C / Bar ÷ °F / PSI
- **Ec42** Type of relative / absolute pressure  
Used to select whether the pressure detected by the transducers is relative or absolute

## 8.2 Parameters to configure the relays and digital inputs

- **Ec35...Ec36** Configuration of relays RL1 and RL2  
Used to enable the alarm output via the relay
- **Ec37...Ec40** Configuration of digital inputs IC1..ID4  
Used to configure functions to be associated with the digital inputs

## 8.3 Display view setting parameters

- **Ec43** Upper display view  
Used to select the
- **Ec44** Bottom display view  
Used to select the size to show on the lower display
- **Ec45** Percentage view with decimal point  
Used to select whether the aperture percentage of the valve is expressed with a decimal point or not

## 8.4 Valve configuration parameters

- **Ec3=** valve type selection: unipolar o bipolar;
- **Ec9 / Ec18** = bipolar valve model selection (you can choose among different preconfigured valves)



- **Ec10 / Ec19** = unipolar valve model selection; parameters currently not used
- **Ec11 / Ec20** = a certain number of steps are added when the valve closes to ensure full closure
- **Ec12 / Ec21** = number of re-aperture steps following the full closure
- **Ec13 / Ec22** = maximum number of valve adjustment steps (value to be calculated based on the technical documentation of the valve)
- **Ec14 / Ec23** = minimum number of valve adjustment steps (value to be calculated based on the technical documentation of the valve)
- **Ec15 / Ec24** = maximum movement current value of the bipolar valve (value to be calculated based on the technical documentation of the valve)
- **Ec16 / Ec25** = holding current value of the bipolar valve (value to be calculated based on the technical documentation of the valve)
- **Ec17 / Ec26** = maximum number of steps per second that can be carried out by the valve (value to be calculated based on the technical documentation of the valve)
- **Ec50 / Ec52** = type of movement or holding current: peak or RMS current. This is an important value for the manual setting of the valve; some manufacturers declare the maximum current values and still current values expressed as a peak value or an RMS value (value to be calculated based on the technical documentation of the valve)
- **Ec51 / Ec53** = type of current signal; this is an important value for the manual setting of the valve. Some manufacturers use a microstepping or normal-mode control for their own valves (value to be calculated based on the technical documentation of the valve)
- **Ec54** = **only reading parameter**; through this parameter it is possible to read how many gases are selectable by Ec8 parameter

## 8.5 System configuration parameters

- **Ec4 / Ec5** = selection of the valves operating mode (cooling only / heating only / both)
- **Ec6 / Ec7** = selection of the cooling circuit of valve 1 and 2
- **Ec8** = type of gas used in the system (R134a, R407c,...)

## 8.6 Adjustment parameters

- **Et1 / Et4** = number of aperture steps at which the valve is set when the adjustment starts and before turning on the compressor (if the IEV is used with a LAN connection to an IC200 EVO)
- **Et7 / Et27** = proportional contribution of the PID regulator in summer and winter mode. If this parameter is set to 0, the Self-adaptive adjustment function is enabled. Increasing the value means increasing the action  $\Delta t$  of the proportional part; therefore, upon start-up of the deviation of the superheating calculated in relation to the setpoint value, increasing the value means that the proportional part provides a smaller contribution to adjustment.
- **Et8 / Et28** = integral time of the PID regulator in summer and winter adjustment mode. Indicates the action time of the integral component; increasing the value means setting more time to calculate the integral component.
- **Et9 / Et29** = derivative constant of the PID regulator in summer and winter adjustment mode.
- **Et10 / Et30** = superheating setpoint value in summer and winter mode

- **Et11 / Et31** = adjustment dead band. Within the dead band  
 Summer superheating setpoint – Et11 ÷ Summer superheating setpoint + Et11  
 in summer mode  
 Winter superheating setpoint – Et31 ÷ Winter superheating setpoint + Et31 in  
 winter mode

no action is taken in terms of adjustment. This will maintain the value calculated the moment before entering the band

- **Et12 / Et32** = high superheating threshold  
 If the calculated superheating exceeds this value and remains above it for the Et49 time, the regulator carried out corrections on the adjustment (in terms of valve aperture) in order to reduce the superheating value and drop below this threshold again
- **Et13 / Et33** = low superheating threshold  
 If the calculated superheating is below this value and remains below this value for the Et50 time, the regulator carried out corrections on the adjustment (in terms of valve closure) in order to increase the superheating value and go above this threshold again
- **Et14 / Et34** = additional integral time to prevent low overheating in summer and winter mode  
 This parameter is used to increase the integral component in the event of low superheating
- **Et15 / Et35** = maximum MOP operating pressure threshold  
 Once the maximum operating pressure has been exceeded, the regulator corrects the adjustment by closing the valve, for each second that passes, of the value expressed with parameter Et16 / Et36
- **Et16 / Et36** = number of steps during closure or aperture during the MOP and LOP phases
- **Et17 / Et37** = minimum LOP operating pressure threshold  
 Once the minimum operating pressure has been exceeded, the regulator corrects the adjustment by opening the valve, for each second that passes, of the value expressed with parameter Et16 / Et36
- **Et18 / Et38** = percentage decrease of the valve when the low superheating threshold is exceeded  
 Once the low superheating threshold has been exceeded, the regulator corrects the adjustment by opening the valve, for each second that passes, of the value expressed with parameter Et18 / Et38
- **Et19 / Et39** = maximum aperture percentage of the valve in cooling and heating mode  
 Under special circumstances there might be the need to change the maximum aperture value of the valve. This can be done by setting the suitable value for this parameter.
- **Et20 / Et40** = minimum aperture percentage of the valve in cooling and heating mode  
 Under special circumstances there might be the need to change the minimum aperture value of the valve. This can be done by setting the suitable value for this parameter.
- **Et21 / Et41** = filter for the pressure measurement in cooling and heating mode  
 These parameters can be used to slow down the pressure reading, which effectively serves as a filter in the event of extensive pressure
- **Et22 / Et42** = filter for the temperature measurement in cooling and heating mode  
 These parameters can be used to slow down the temperature reading, which effectively serves as a filter in the event of extensive temperature
- **Et23 / Et43** = time for which aperture is maintained from when the adjustment starts  
 When the adjustment starts, the valve is open at the value set under parameters Et1 / Et4 and it is "frozen" in this state for the Et23 / Et43 time.  
 If the IEV is connected via LAN to the I chill 200EVO, the consent to turn on the compressor is given once this time has elapsed; if the IEV is in STD\_ALONE mode when the adjustment

starts, the valve will keep the aperture set for the Et23 / Et43 time without “synching” with the start-up of the compressor

- **Et24 / Et44** = time to update the aperture and closure of the valve  
This parameter is used to change, if necessary, the time to update the aperture and close of the valve
- **Et25 / Et45** = aperture time of the valve in the event of a probe error  
In the event of a probe failure, the aperture of the valve is increased by Et26 / Et45 percent every Et25 / Et45 seconds
- **Et26 / Et46** = aperture percentage of the valve in the event of a probe error  
In the event of a probe failure, the aperture of the valve is increased by Et26 / Et45 percent every Et25 / Et45 seconds
- **Et47** = LOP alarm signal delay
- **Et48** = MOP alarm signal delay
- **Et49** = High superheating alarm signal delay
- **Et50** = Low superheating alarm signal delay
- **Et51** = PID proportional constant in defrost mode  
During operation in defrost mode, the valve's adjustment is carried out in accordance with the cooling mode, except for the fact that the value of the PID proportional constant, which is the dedicated Et51 parameter
- **Et52** = Number of aperture steps of valve 1 before the adjustment in defrost mode  
At the time of entry in defrost mode, the valve sets itself to the number of steps set under parameter Et52 for the Et53 time
- **Et53** = Time for which the steps of valve 1 are maintained before the adjustment for defrost
- **Et54** = Number of aperture steps of valve 2 before the adjustment in defrost mode  
At the time of entry in defrost mode, the valve sets itself to the number of steps set under parameter Et54 for the Et55 time
- **Et55** = Time for which the steps of valve 2 are maintained before the adjustment for defrost

## 8.7 Other parameters

- **Ec46** = Communication address of the Modbus protocol
- **Ec47** = LAN communication protocol address  
If the driver is used in LAN configuration with a I chill 200 EVO, the communication address must be assigned both to the I chill and the IEV driver (the address is the same both in I chill and IEV)
- **Ec48** = Map code  
Read-only parameter that identifies the parameter map code
- **Ec49** = Firmware version  
Read-only parameter that identifies the firmware version
- **Pr2** = Access password Pr2 and Alarm Log reset

## 9. Parameters table

Parameter	Description	Min	Max	Unit of measure	Resolution
<b>Ec 1</b>	IEV driver operation mode 0= Stand-alone 1= LAN for Ichill EVO	0	1		
<b>Ec 2</b>	Low pressure probes position 0= IEV 1= Ichill 200 EVO	0	1		
<b>Ec 3</b>	Type of valve: 0 = Unipolar 1 = Bipolar	0	1		
<b>Ec 4</b>	Valve 1 output operation mode 0 = chiller 1 = heat pump 2 = chiller and heat pump	0	2		
<b>Ec 5</b>	Valve 2 output operation mode 0 = chiller 1 = heat pump 2 = chiller and heat pump	0	2		
<b>Ec 6</b>	Selection of output circuit valve 1 0 = Not present 1 = Circuit 1 2 = Circuit 2	0	2		
<b>Ec 7</b>	Selection of output circuit valve 2 0 = Not present 1 = Circuit 1 2 = Circuit 2	0	2		
<b>Ec 8</b>	Gas selection 0= R22 1= R134a 2= R404a 3= R407c 4= R410a 5= R507c 6= CO2 7= 1234ZE 8= R407F 9= R290 10= R449A 11= R452A	0	11		
<b>Valve 1 configuration</b>					

<b>Ec 9</b>	<p>Selection of the bipolar valve body connected to the driver (<b>WARNING: the unique and valid reference has to be considered the datasheet made by valve manufacturer</b>)</p> <p>0 = Custom  1 = Danfoss ETS – 25/50  2 = Danfoss ETS – 100  3 = Danfoss ETS – 250/400  4 = Sporlan SEI 0.5 – 11  5 = Sporlan SEI 1.5 – 20  6 = Sporlan SEI 30  7 = Sporlan SER (I) G,J,K  8 = Sporlan SEH 50  9 = Sporlan SEH 100  10 = Sporlan SEH 175  11 = Alco EX4 – EX5 – EX6  12 = Alco EX7  13 = Alco EX8  14 = Configuration 1  15 = Configuration 2</p>	0	15		
<b>Ec 10</b>	<p>Selection of the unipolar valve body connected to the driver</p> <p>0 = Custom</p>	0	0		
<b>Ec 11</b>	<p>Number of additional steps to achieve complete closure. When a closing request is received, the valve starts from the current number of steps and moves to 0, then closes for the set number of steps.</p> <p>For unipolar valves refer to the notes included in paragraph 7.3.</p>	0	8000	Full steps	
<b>Ec 12</b>	<p>Number of return steps in opening mode after the valve has been closed completely. These decompress any closing spring inside the valve or to prevent sealing the circuit.</p> <p>For unipolar valves refer to the notes included in paragraph 7.3.</p>	0	500	Full steps	
<b>Ec 13</b>	<p>Maximum number of adjusting steps of the valve 1  (this value is set automatically by the controller if EC9&gt; 0).</p> <p>For unipolar valves refer to the notes included in paragraph 7.3.</p>	Ec14	8000	Full steps	
<b>Ec 14</b>	<p>Minimum number of adjusting steps of the valve 1  (this value is set automatically by the controller if EC9&gt; 0).</p> <p>For unipolar valves refer to the notes included in paragraph 7.3.</p>	0	Ec13	Full steps	

<b>Ec 15</b>	Maximum current value per phase of the stepper motor (this value is set automatically by the controller if EC9> 0)	Ec16	100	mA	x10 mA
<b>Ec 16</b>	Current stand-by value (this value is set automatically by the controller if EC9> 0)	0	Ec15	mA	x10 mA
<b>Ec 17</b>	Maximum number of steps per second of the valve. For unipolar valves refer to the notes included in paragraph 7.3.	0	600	Full steps	
<b>Valve 2 configuration</b>					
<b>Ec 18</b>	Selection of the bipolar valve body connected to the driver ( <b>WARNING the unique and valid reference has to be considered the datasheet made by valve manufacturer</b> ) 0 = Custom 1 = Danfoss ETS – 25/50 2 = Danfoss ETS – 100 3 = Danfoss ETS – 250/400 4 = Sporlan SEI 0.5 – 11 5 = Sporlan SEI 1.5 – 20 6 = Sporlan SEI 30 7 = Sporlan SER (I) G,J,K 8 = Sporlan SEH 50 9 = Sporlan SEH 100 10 = Sporlan SEH 175 11 = Alco EX4 – EX5 – EX6 12 = Alco EX7 13 = Alco EX8 14 = Configuration 1 15 = Configuration 2	0	15		
<b>Ec 19</b>	Selection of the unipolar valve body connected to the driver 0 = Custom	0	0		
<b>Ec 20</b>	Number of additional steps to achieve complete closure. When a closing request is received, the valve starts from the current number of steps and moves to 0, then closes for the set number of steps. For unipolar valves refer to the notes included in paragraph 7.3.	0	8000	Full steps	
<b>Ec 21</b>	Number of return steps in opening mode after the valve has been closed completely. These decompress any closing spring inside the valve or to prevent sealing the circuit. For unipolar valves refer to the notes included in paragraph 7.3.	0	500	Full steps	

<b>Ec 22</b>	Maximum number of adjusting steps of the valve 2 (this value is set automatically by the controller if EC18> 0). For unipolar valves refer to the notes included in paragraph 7.3.	Ec23	8000	Full steps	
<b>Ec 23</b>	Minimum number of adjusting steps of the valve 2 (this value is set automatically by the controller if EC18> 0). For unipolar valves refer to the notes included in paragraph 7.3.	0	Ec22	Full steps	
<b>Ec 24</b>	Maximum current value per phase of the stepper motor (this value is set automatically by the controller if EC18> 0)	Ec25	100	mA	x10 mA
<b>Ec 25</b>	Current stand-by value (this value is set automatically by the controller if EC18> 0)	0	Ec24	mA	x10 mA
<b>Ec 26</b>	Maximum number of steps per second of the valve. For unipolar valves refer to the notes included in paragraph 7.3.	0	600	Hz	
<b>I/O Configuration</b>					
<b>Ec 27</b>	Pb1 and Pb2 configuration (Pb1 used for valve 1 and Pb2 used for valve 2) 0 = temperature (NTC probe) 1 = temperature (PTC probe) 2 = temperature (PT1000 probe)	0	2		
<b>Ec 28</b>	Pb3 and Pb4 configuration (Pb3 used for valve 1 and Pb4 used for valve 2) 0 = temperature (NTC probe) 1 = temperature (PTC probe) 2 = temperature (PT1000 probe) 3 = pressure (4÷20mA signal) 4 = pressure (0÷5V signal)	0	4		
<b>Ec 29</b>	Pressure value at 4mA / 0,5V	0.0 0	Ec30	Bar Psi	Dec int
<b>Ec 30</b>	Pressure value at 20mA / 4.5V	Ec29	50.0 725	Bar Psi	Dec int
<b>Ec 31</b>	PB1 calibration	-12.0 -21	12.0 21	°C °F	Dec int
<b>Ec 32</b>	PB2 calibration	-12.0 -21	12.0 21	°C °F	Dec int

<b>Ec 33</b>	PB3 calibration	-12.0 -21 -12.0 -174	12.0 21 12.0 174	°C °F Bar Psi	Dec int dec int
<b>Ec 34</b>	PB4 calibration	-12.0 -21 -12.0 -174	12.0 21 12.0 174	°C °F Bar Psi	Dec int dec int
<b>Ec 35</b>	Relay 1 configuration (o1= active when the contact is open; c1= when active the contact is closed) 0= non used 1= active in case of circuit 1 probe error 2= active in case of MOP, LOP and circuit 1 probe error 3= active in case of high superheating, low superheating, and circuit 1 probe error 4= active in case of MOP, LOP, high superheating, low superheating and circuit 1 probe error 5= active in case of circuit 2 probe error 6= active in case of MOP, LOP and circuit 2 probe error 7= active in case of high superheating, low superheating, and circuit 2 probe error 8= active in case of MOP, LOP, high superheating, low superheating and circuit 2 probe error	0	c8		
<b>Ec 36</b>	Relay 2 configuration (o1= active when the contact is open; c1= when active the contact is closed) 0= not used 1= active in case of circuit 1 probe error 2= active in case of MOP, LOP and circuit 1 probe error 3= active in case of high superheating, low superheating, and circuit 1 probe error 4= active in case of MOP, LOP, high superheating, low superheating and circuit 1 probe error 5= active in case of circuit 2 probe error 6= active in case of MOP, LOP and circuit 2 probe error 7= active in case of high superheating, low superheating, and circuit 2 probe error 8= active in case of MOP, LOP, high superheating, low superheating and circuit 2 probe error	0	c8		



<b>Ec 37</b>	<p>Digital input 1 configuration (o1= active when the contact is open; c1= when active the contact is closed)</p> <p>0= not used  1= circuit 1 valve activation  2= circuit 1 valve operation mode (cooling or heating)  3= circuit 1 defrost mode  4= circuit 2 valve activation  5= circuit 2 valve operation mode (cooling or heating)  6= circuit 2 defrost mode</p>	0	c6		
<b>Ec 38</b>	<p>Digital input 2 configuration (o1= active when the contact is open; c1= when active the contact is closed)</p> <p>0= not used  1= circuit 1 valve activation  2= circuit 1 valve operation mode (cooling or heating)  3= circuit 1 defrost mode  4= circuit 2 valve activation  5= circuit 2 valve operation mode (cooling or heating)  6= circuit 2 defrost mode</p>	0	c6		
<b>Ec 39</b>	<p>Digital input 3 configuration (o1= active when the contact is open; c1= when active the contact is closed)</p> <p>0= not used  1= circuit 1 valve activation  2= circuit 1 valve operation mode (cooling or heating)  3= circuit 1 defrost mode  4= circuit 2 valve activation  5= circuit 2 valve operation mode (cooling or heating)  6= circuit 2 defrost mode</p>	0	c6		
<b>Ec 40</b>	<p>Digital input 4 configuration (o1= active when the contact is open; c1= when active the contact is closed)</p> <p>0= not used  1= circuit 1 valve activation  2= circuit 1 valve operation mode (cooling or heating)  3= circuit 1 defrost mode  4= circuit 2 valve activation  5= circuit 2 valve operation mode (cooling or heating)  6= circuit 2 defrost mode</p>	0	c6		

Display configuration and Modbus address configuration					
<b>Ec 41</b>	Unit of measure 0= °C/bar 1= °F/psi	0	1		
<b>Ec 42</b>	Pressure measurement: 0 = relative 1= absolute	0	1		
<b>Ec 43</b>	Upper display visualization 0= not used 1= superheating 2= suction temperature 3= evaporating temperature	0	3		
<b>Ec 44</b>	Lower display visualization 0= not used 1= superheating 2= valve opening (%) 3= suction temperature 4= evaporating pressure 5= evaporating temperature	0	5		
<b>Ec 45</b>	Opening percentage visualization 0= no decimal point 1= decimal point	0	1		
<b>Ec 46</b>	Modbus address	1	247		
<b>Ec 47</b>	LAN address (used only if connected to the IC200 EVO)	1	247		
<b>Ec 48</b>	Map code (only reading)	0	9999		
<b>Ec 49</b>	Firmware release (only reading)				
<b>Ec 50</b>	Type of current valve 1: peak or RMS 0= peak 1= RMS (this value is set automatically by the controller if EC9> 0)	0	1		
<b>Ec 51</b>	Type of signal valve 1: microstepping o normal mode 0= microstepping 1= normal mode (this value is set automatically by the controller if EC9> 0)	0	1		
<b>Ec 52</b>	Type of current valve 2: peak or RMS 0= peak 1= RMS (this value is set automatically by the controller if EC18> 0)	0	1		

<b>Ec 53</b>	Type of signal valve 2: microstepping o normal mode 0= microstepping 1= normal mode (this value is set automatically by the controller if EC18> 0)	0	1		
<b>Ec 54</b>	Number of available gases selectable by Ec8 parameter. This is an only reading parameter, used to define the maximum value of Ec8 parameter.	1	247		
<b>Pr2</b>	Password to enter in Pr2 level and password to reset the alarm log	0	9999		



Parameter	Description	Min	Max	Unit of measure	Resolution
<b>Valve 1 configuration</b>					
<b>Et 1</b>	Number of steps the valve has to move before compressor start-up. 0 = function is disabled	Ec14	Ec13	Full steps	
<b>Et 2</b>	Sets valve manual operation mode 0= Automatic 1= Manual (valve is open to Et3 steps)	0	1		
<b>Et 3</b>	Absolute number of steps the valve has to move in manual mode	Ec14	Ec13	Full steps	
<b>Valve 2 configuration</b>					
<b>Et 4</b>	Number of steps the valve has to move before compressor start-up. 0 = function is disabled	Ec23	Ec22	Full steps	
<b>Et 5</b>	Sets valve manual operation mode 0= Automatic 1= Manual	0	1		
<b>Et 6</b>	Absolute number of steps the valve has to move in manual mode	Ec23	Ec22	Full steps	
<b>PID configuration in chiller mode (valve 1 and valve 2)</b>					
<b>Et 7</b>	PID proportional constant in chiller mode	0.0 0	50.0 122	°C °F	Dec Int
<b>Et 8</b>	PID integral time in chiller mode	0	250	Sec	
<b>Et 9</b>	PID derivative constant in chiller mode	0	250	Sec	
<b>Et 10</b>	Overheating regulation set point during chiller mode	0.0 0	25.0 77	°C °F	dec Int
<b>Et 11</b>	Overheating regulation dead band in chiller mode	0.0 0	5.0 41	°C °F	dec Int
<b>Et 12</b>	High overheating threshold in chiller mode. The alarm status is signaled after the high overheating alarm activation delay	Et46	80.0 176	°C °F	dec Int

<b>Et 13</b>	Low overheating threshold in chiller mode. The alarm status is signaled after the low overheating alarm activation delay	0.0 0	Et46	°C °F	dec Int
<b>Et 14</b>	Low overheating protection added integral time in chiller mode	0	250	Sec	
<b>Et 15</b>	MOP Protection activation threshold in chiller mode. High evaporating temperature threshold. The alarm status is signaled after the high evaporating temperature alarm activation delay	-70.0 -94	60.0 140	°C °F	dec Int
<b>Et 16</b>	STEP RATE during MOP or LOP protection (number of steps every second) in chiller mode	0	8000	Full steps	
<b>Et 17</b>	LOP Protection activation threshold in chiller mode. Low evaporating temperature threshold. The alarm status is signaled after the low evaporating temperature alarm activation delay	-70.0 -94	60.0 140	°C °F	dec Int
<b>Et 18</b>	Percentage decreasing in case of low superheating condition in chiller mode	0	100	%	
<b>Et 19</b>	Maximum value of valve opening in chiller mode (percentage)	Et20	100	%	
<b>Et 20</b>	Minimum value of valve opening in chiller mode (percentage)	0	Et19	%	
<b>Et 21</b>	Pressure measure filter in chiller mode	1	250	Sec	
<b>Et 22</b>	Temperature measure filter in chiller mode	1	250	Sec	
<b>Et 23</b>	Holding time of Et1 steps at the start-up of the regulation in chiller mode	0	250	Sec	
<b>Et 24</b>	Interval of updating valve position in chiller mode	0	120	Sec	
<b>Et 25</b>	Interval time for valve opening when a probe is damaged in chiller mode	0	250	Sec	
<b>Et 26</b>	Valve opening percentage when a probe is damaged in chiller mode	0	100	%	
<b>PID configuration in heat pump mode (valve 1 and valve 2)</b>					
<b>Et 27</b>	PID proportional constant in heat pump mode	0.0 0	50.0 122	°C °F	dec Int
<b>Et 28</b>	PID integral time in heat pump mode	0	250	Sec	
<b>Et 29</b>	PID derivative constant in heat pump mode	0	250	Sec	
<b>Et 30</b>	Overheating regulation set point during heat pump mode	0.0 0	25.0 77	°C °F	dec Int



<b>Et 31</b>	Overheating regulation dead band in heat pump mode	0.0 0	5.0 41	°C °F	dec Int
<b>Et 32</b>	High overheating threshold in heat pump mode. The alarm status is signaled after the high overheating alarm activation delay	Et33	80.0 176	°C °F	dec Int
<b>Et 33</b>	Low overheating threshold in heat pump mode. The alarm status is signaled after the low overheating alarm activation delay	0.0 0	Et32	°C °F	dec Int
<b>Et 34</b>	Low overheating protection added integral time in heat pump mode	0	250	Sec	
<b>Et 35</b>	MOP Protection activation threshold in heat pump mode. High evaporating temperature threshold. The alarm status is signaled after the high evaporating temperature alarm activation delay	-70.0 -94	60.0 140	°C °F	dec Int
<b>Et 36</b>	Step Rate during MOP or LOP protection (number of steps every second) in heat pump mode	0	8000	Full steps	
<b>Et 37</b>	LOP Protection activation threshold in heat pump mode. Low evaporating temperature threshold. The alarm status is signaled after the low evaporating temperature alarm activation delay	-70.0 -94	60.0 140	°C °F	dec Int
<b>Et 38</b>	Percentage decreasing in case of low superheating condition in heat pump mode	0	100	%	
<b>Et 39</b>	Max. value of valve opening in heat pump mode (percentage)	Et40	100	%	
<b>Et 40</b>	Min. value of valve opening in heat pump mode (percentage)	0	Et39	%	
<b>Et 41</b>	Pressure measure Filter in heat pump mode	1	250	Sec	
<b>Et 42</b>	Temperature measure filter in heat pump mode	1	250	Sec	
<b>Et 43</b>	Holding time of Et4 steps at the start-up of the regulation in heat pump	1	250	Sec	
<b>Et 44</b>	Interval of updating the valve output in heat pump mode	0	120	Sec	
<b>Et 45</b>	Interval time for valve opening when a probe is damaged in heat pump mode	0	250	Sec	
<b>Et 46</b>	Valve opening percentage when a probe is damaged in heat pump mode	0	100	%	
<b>MOP / LOP alarm</b>					
<b>Et 47</b>	Low pressure alarm activation delay (LOP)	0	250	Sec	
<b>Et 48</b>	High pressure alarm activation delay (MOP)	0	250	Sec	
<b>Et 49</b>	High overheating alarm activation delay	0	250	Sec	10 Sec
<b>Et 50</b>	Low overheating alarm activation delay	0	250	Sec	10 Sec
<b>Defrost</b>					

<b>Et 51</b>	PID proportional component in defrost	0.0 0	50.0 122	°C °F	dec Int
<b>Et 52</b>	Number of steps the valve 1 has to move before compressor start-up. For unipolar valves refer to the notes included in paragraph 7.3.	Ec14	Ec13	Full steps	
<b>Et 53</b>	Holding time of Et52 steps at the start-up of the defrost (valve 1)	0	250	Sec	
<b>Et 54</b>	Number of steps the valve 2 has to move before compressor start-up. For unipolar valves refer to the notes included in paragraph 7.3.	Ec23	Ec22	Full steps	
<b>Et 55</b>	Holding time of Et52 steps at the start-up of the defrost (valve 2)	0	250	Sec	

## 10. Alarm codes and actions

Code displayed	Meaning	Cause of alarm	Action taken	Type of reset
<b>AP1</b> ... <b>AP4</b>	Alarm of probe PB1, Pb2, Pb3 or Pb4	Faulty probe or value out of range	Blocked adjustment by the valve closing; Active alarm relay output if enabled by parameter; Enable the buzzer; icon flashes;  Code of alarm on the display.	Automatic when connection problems are solved or after probe replacement.
<b>MoP</b>	Maximum operating pressure	Evaporation pressure converted to temperature > MOP activation threshold delayed by Et40 seconds	Automatic action of the controller to counteract the MoP; Active alarm relay output if enabled by parameter; Enable the buzzer; icon flashes;  Code of alarm on the display.	Automatic. If the equivalent temperature of the pressure probe drops below Et15/Et35 - 1.0°C, the driver carries out the aperture of the valve by Et16/Et36 steps at each second of operation. The alarm is cleared only when the superheating temperature drops below the superheating setpoint value.

<b>LoP</b>	Minimum operating pressure	Evaporation pressure < LOP activation threshold delayed by Et39 seconds	Automatic action of the controller to counteract the LoP; Active alarm relay output if enabled by parameter; Enable the buzzer; icon flashes;  Code of alarm on the display.	Automatic. The condition to come out from minimum operating pressure are: - the equivalent temperature of the pressure probe exceeds Et17/Et37 + 4.0°C - Et17 < Evaporation pressure converted to temperature < Et17+4°C and superheating < Et13 (low superheating set point) After LOP alarm reset, the driver carries out the aperture of the valve by Et16/Et36 steps at each second of operation
<b>HSH</b>	Maximum super heating value	Super heating value > High superheating threshold Et12 / Et32 delayed by Et41 seconds	Automatic action of the controller to counteract the HSH; Active alarm relay output if enabled by parameter; Enable the buzzer; icon flashes;  Code of alarm on the display.	Automatic when the superheating is less or equal to Et12/Et32 – 1.0°C
<b>LSH</b>	Minimum super heating value	Super heating value < Low superheating threshold Et13 / Et33 delayed by Et42 seconds	Automatic action of the controller to counteract the LSH; Active alarm relay output if enabled by parameter; Enable the buzzer; icon flashes;  Code of alarm on the display.	Automatic when the superheating temperature is higher or equal to Et13/Et33 + 1.0°

<b>ALAn</b>	No serial communication with Ichill	Problem related to serial communication with Ichill	Blocked adjustment by the valve closing; Active alarm relay output if enabled by parameter; Enable the buzzer; Icon flashes;  Code of alarm on the display.	Automatic on the fault being resolved: <ul style="list-style-type: none"> <li>• LAN connection polarity complied with</li> <li>• replace the ichill controller, IEV or both</li> </ul>
<b>ACF1</b>	Configuration alarm	Configuration alarm (due to wrong configuration of valves and circuits)	Valve closed; Active alarm relay output if enabled by parameter; Enable the buzzer; Icon flashes;  Code of alarm on the display.	Automatic after changing the configuration

ACF1 alarm:

- STAND-ALONE: valve configured to operate in cooling and heating but no digital input configured as cooling or heating selection
- Two valves configured for the same circuit and configured to work both in the same mode (both only chiller, both only heat pump, both chiller and heat pump)
- Two valves configured for the same circuit and at least one is configured to operate in chiller and heat pump

## 11. Parameter programming key - HotKey 4K

The HotKey 4K programming key allows you to program the parameters of the IEV valve driver. The HotKey 4K must be inserted into the 5-pin connector of the TTL serial port. The possible operations are **Downloading** (loading parameters from the key to the controller) or **Uploading** (downloading parameters from the controller to the key).



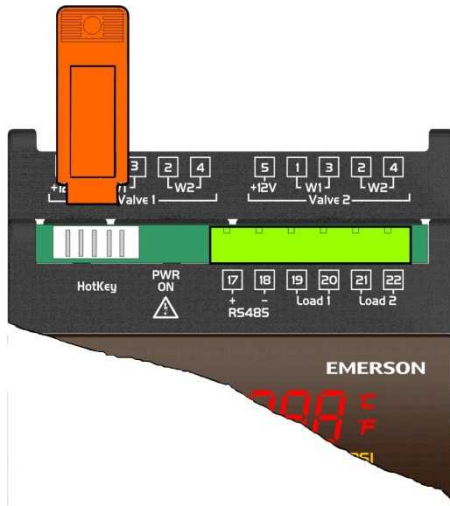

## 11.1 Download

The download occurs automatically if:

- the HotKey 4K is inserted into the connector 5-way while the device is not powered
- the instrument is powered
- the download started

If the device detects the presence of the programming key (connected to the serial port), a key recognition process is launched that involves verification of compatibility of the data and then the data loading process from the key is launched and the data are saved in the internal memory.

## 11.2 Upload

Procedure to upload:

- insert the key in the 5-way connector with the device switched ON
- press the menu key and search for **UPL** in the lower display
- press **SET**
- the **UPL** label flashes on the display to indicate the procedure has begun
- once the operation is complete, the fixed **UPL** label will appear together with the **End** label to indicate that the operation was successful.

All these steps can end earlier due to a communication error with the key when the dialogue between the device and the key for some reason is not successful or if the data writing control fails. In this case, the **Err** (Communication Label) label appears on the display, indicating that the operation failed. Otherwise, the **End** label appears if all goes well.

## 12. Serial output

The IEV valve driver has an RS485 or TTL serial output (only 1 of the 2 outputs can be used) for the following possible uses:

- connection to a Personal computer: the configuration parameters of the driver can be programmed via Wizmate Prog Tool kit
- XWEB system connection to supervise the operation of the valve driver
- connection to a third party supervision system; the valve driver has Modbus RTU protocol inside, with which the operating data can be read

## 13. Maximum power allowed

The IEV valve driver can control different types of motorised valves. The following table shows the maximum current values that the windings of the valves can absorb.

Select the transformer that is suitable for the application on the basis of that shown in the table. The type of Dixell transformer to use is indicated for every operating mode.

Do not disconnect or connect a valve to the IEV driver when it is connected to the power supply; the connection or disconnection of the valve must always be done when the IEV driver is not connected to power supply (IEV driver can be damaged).

### NOTE:

Carefully read the technical manual supplied by the manufacturer of the valve body before using the driver in order to prevent changing the data provided by the manufacturers of the valves, and verify that the required currents are lower than those shown in the table below in order to prevent damaging the control module.

		CONFIGURATION	
		ONE VALVE	TWO VALVES
DRIVE MODE		Entire step	Entire step
TYPE OF VALVE	BIPOLAR Valves (4 wires)	Current 0.9A max → TF20D	Current 0.9A max per valve → TF40D
	UNIPOLAR valves (5-6 wires)	Current 0.33A max → TF20D	Current 0.33A max per valve → TF20D

## 14. Installation

The devices should not be installed in areas where there are the following situations:

- use the controller only within the operating limits, avoiding sudden temperature changes with high atmospheric humidity (to prevent formation of condensates)
- High mechanical stress (vibration and / or impact)
- Gas sulfuric and ammonia fumes, saline mist that can cause corrosion and / or oxidation
- Presence of flammable gases and explosives
- Presence of dust
- Presence of devices that generate magnetic interference
- Place the device in cabinets where it is ensured:
  - adequate distance between the device and other electrical high power components or power cables
  - there must be sufficient cooling air

Always obey the laws and regulations in force in the country where the device is installed.

Always protect the device so that it is always accessible and only by authorized personnel.

In the event of malfunctions, to repair the device always consult your distributor.

### 14.1 General rules

During installation respect the following warnings to prevent malfunctions of the device:

- Before connecting the instrument, make sure the power supply complies with declared on the label affixed to the side of the instrument and in this document
- Set the programming of the configuration parameters before connecting the valve; the connection of a valve with features not compatible with the model set in the device can result in a failure of the device or to the valve
- Before beginning any maintenance operation, disconnect all electrical connections of the instrument
- Do not disconnect or connect a valve to the IEV driver when it is connected to the power supply; the connection or disconnection of the valve must always be done when the IEV driver is not connected to power supply (IEV driver can be damaged).
- The maximum distance between a driver valve IEV and the valve must not be more than 10 meters; shielded cables must be used in section greater than or equal to 0,325 mm<sup>2</sup> (AWG 22)
- Separate the power supply of the device from that of other electrical components
- When possible, don't connect the secondary coil of the transformer to the ground

## 14.2 Analogue input connection

### 14.2.1 Temperature probes (NTC and PTC)

2-row sensors that do not require polarity to be respected.

Each sensor must be connected through one of the inputs (from Pb1 to Pb10) and the common (Pbc) as shown in the diagram below.

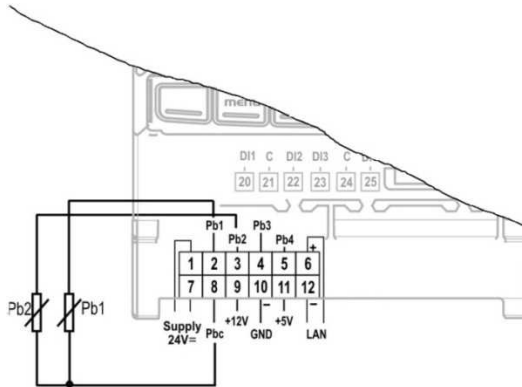

Recommendations:

- follow the diagram of the device used, for the numbering.
- the configuration is determined by the application.
- if used as a digital input (potential free - not live), use the same connection configuration as of the sensors.

### 14.2.2 Pressure transducers and current probes (4 - 20 mA)

2-row sensors that require +12Vdc power supply.

Each sensor must be connected through one of the inputs (from Pb1 to Pb10) and the power supply (+12V) as shown in the diagram below.

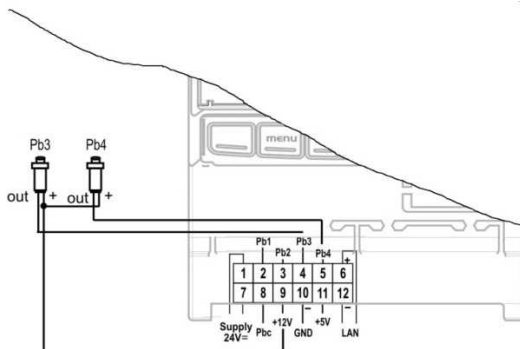

Recommendations:

- follow the diagram of the device used, for the numbering.
- the configuration is determined by the application.

### 14.2.3 Pressure transducers and ratiometric pressure transducers (0 - 5V)

3-row sensors that require +5Vdc power supply.

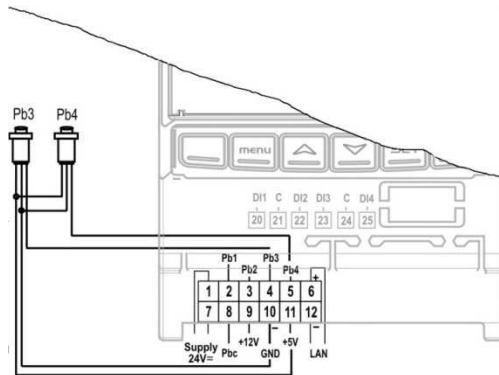

### 14.2.4 Digital input connection

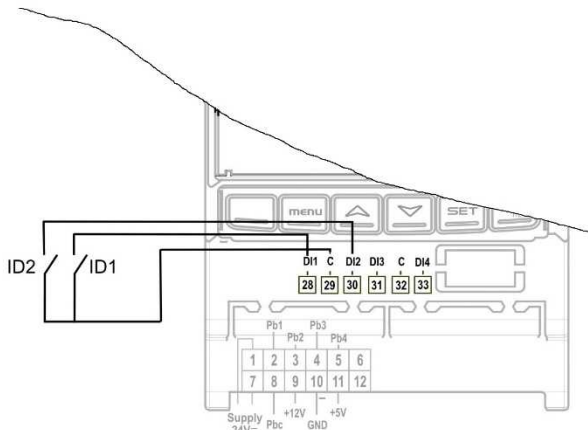

### 14.3 Supercap connection diagram

XEC supercap module supplies the energy to close the valve in case of power down.

XEC supercap doesn't supply the IEV in normal working conditions, but supplies needed energy to close the valve in case of power down.

### Connection with IEV22D (one valve)

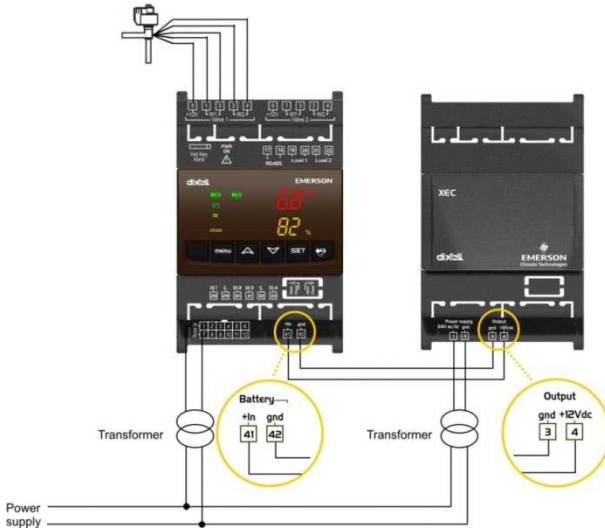

### Connection with IEV24D (two valves)

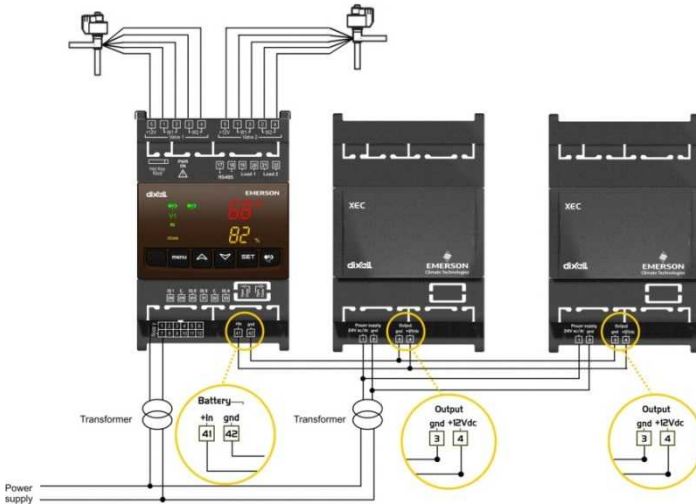

## 14.4 LAN CONNECTION

IEV22D or IEV24D can be connected to an IC200 EVO series (IC206CX EVO, IC208CX EVO, IC205D EVO, IC207D EVO).

Evaporating temperature probe has to be connected to the IEV and suction pressure transducer can be connected to the IEV or to the Ichill (by configuring dedicated parameters).

To guarantee the best regulation is recommended to connect the suction pressure transducer directly to the IEV.

### Connection diagram of Ichill 200 EVO 4 DIN and IEV.

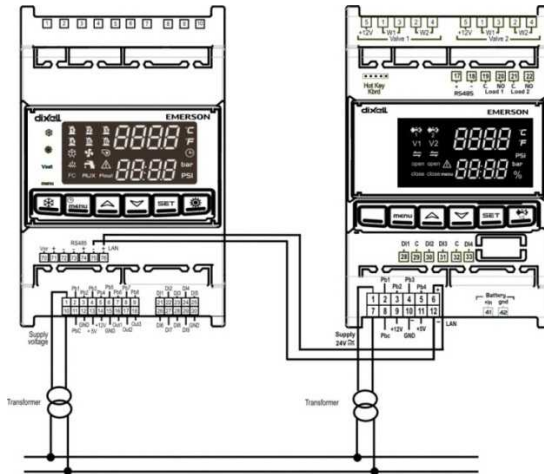

### Connection diagram of Ichill 200 EVO CX and IEV.

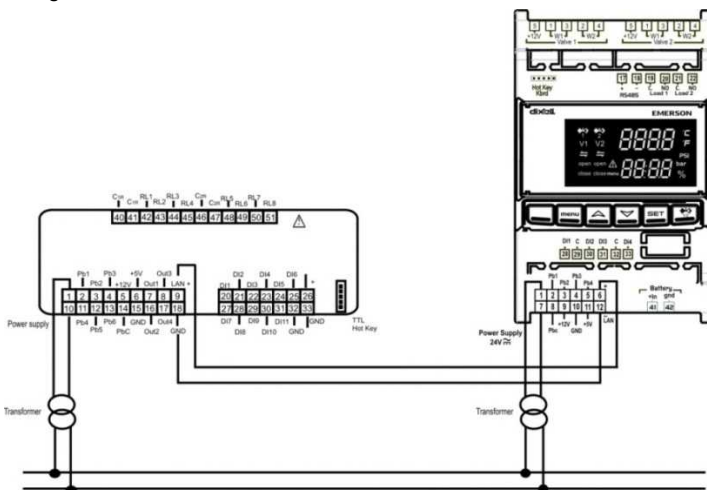

## 15. PLASTIC CONTAINER

The controllers are fitted on a DIN rail (EN 50022, DIN 43880).

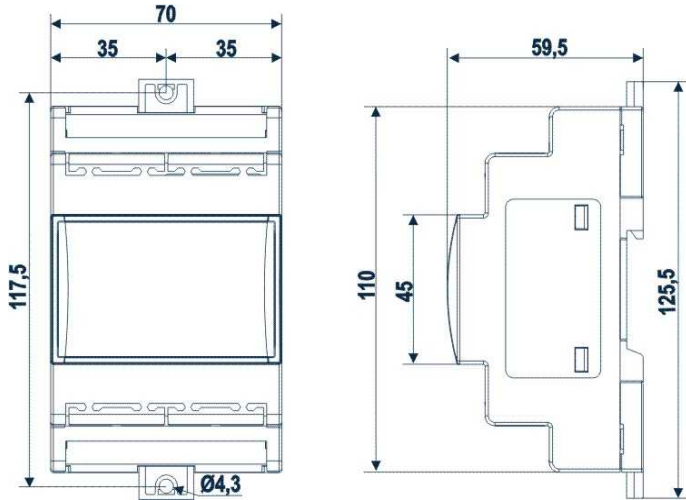

<b>Assembly:</b>	On a DIN rail (EN 50022, DIN 43880) Fastened with screws via the removable plastic flaps.
<b>Material:</b>	PC-ABS Thermoplastic
<b>Self-extinguishing:</b>	V0 (UL94)
<b>Comparative Tracking Index (CTI):</b>	300V
<b>Colour:</b>	Black
<b>Front protection:</b>	IP10

## 16. Technical specifications

### 16.1 Electrical specification

<b>Power Supply:</b>	24Vac/dc -10% ÷ 10%, 50/60Hz
<b>Consumption:</b>	IEV22D: max. 20VA IEV24D: max. 40VA



## 16.2 Analogue inputs

<b>Number of inputs:</b>	4
<b>Type of analogue input:</b> (configurable via software parameter)	NTC (-50T110°C; 10KΩ at 25°C) / (-58T230°F; 10KΩ at 25°C) PTC (-55T150°C; 990Ω at 25°C) / (-58T302°F; 990Ω at 25°C) PT1000 (-50T100°C ; 1K Ω at 0°C) / (-58T212°F; 1KΩ at 0°C) Ratiometric: 0 to 5V (input resistance 3.7KΩ) Current: 4 to 20 mA (input resistance 100Ω)
<b>Precision (at 25°C):</b>	NTC, PTC, PT1000: ±1°C 0-5V: ±100mV 4-20mA: ±0.30mA
<b>Measurement and adjustment field:</b>	-50°C ÷ 110°C (-58 °F ÷ 230°F) NTC probe 0°C ÷ 150°C (32 °F ÷ 302°F) PTC probe -50°C ÷ 100°C (-58°F ÷ 212°F) PT1000 probe 0 bar ÷ 50 bar (0 psi ÷ 302 psi) pressure probe
<b>Resolution</b>	0.1 °C 1 °F 0.1 bar 1 PSI

## 16.3 Digital inputs

<b>Type:</b> (configurable via software parameter)	Non opto-insulated potential free contact
<b>Number of inputs:</b>	4
<b>Notes:</b> 	Do not use live contacts in order to prevent the instrument from being damaged.

## 16.4 Relay outputs

<b>Type:</b>	Relay with NO contacts
<b>Number of outputs:</b>	2
<b>Maximum load:</b>	Relay with normally open contact: 24V 0.5A
<b>Notes:</b> 	Verify the maximum current of the output

## 16.5 Operating conditions

<b>Operating temperature:</b>	-10°C ÷ 55°C
<b>Storage temperature:</b>	-30°C ÷ 85°C
<b>Relative humidity:</b>	20% ÷ 85%
<b>Degree of protection IP</b>	10

**Dixell**



**Dixell S.r.l.** - Z.I. Via dell'Industria, 27 - 32016 Alpago (BL) ITALY  
Tel. +39.0437.9833 r.a. - Fax +39.0437.989313 - EmersonClimate.com/Dixell - dixell@emerson.com