

# Copeland Scroll ZFKQ Compressor

for Refrigeration Applications



Product catalogue

Copeland developed the ZFKQ range of scroll compressors to provide the best performance in low temperatures. The series has a wide application envelope that can operate from -40°C to +7°C evaporating temperature. Its optimized design perfectly fits frozen food application requirements while its scroll compliance mechanism makes it highly tolerant of liquid slugging.

The range consists of:

- The ZF\*KQE models that operate with liquid injection in order to control discharge temperature and extend the operating envelope.
- The ZFI\*KQE models that are optimized for vapor injection with the use of a subcooler. This boosts the refrigeration system's cooling capacity and efficiency.

## Features and benefits

### High efficiency all year round

- The unique Copeland Compliant Scroll design patented by Emerson operates under continuous scroll flank contact, maintained by centrifugal force. This minimizes gas leakage while maximizing efficiency.
- With its capability for condensing operation down to 4°C on low temperature applications, Copeland Scroll technology provides the best seasonal efficiencies.
- Equipped with dynamic discharge valve that allows the discharge gas to reach desired pressure. This helps reduce efficiency loss by preventing gas re-compression.
- The vapor injection technology allows ZFI\*KQE compressors to perform higher efficiency than single-stage compressors at low temperature operation condition. Thus makes ZFI\*KQE the best in-class performance.

### Compactness

- The small footprint of Copeland scroll compressors enables compact system designs.
- Weight and dimensions for refrigeration equipment is reduced with increased capacity per compressor weight.

### Robustness and reliability

- The Copeland Compliant Scroll design is tolerant to stresses caused by liquid slugging, flooded starts and debris commonly found in refrigeration systems.
- Easy to service and maintain due to their compact size and lightweight, simple design.
- Engineered for optimum performance with today's chlorine-free refrigerants.
- The Copeland Scroll compressor design has several inherent reliability advantages:
  - 70% fewer moving parts than reciprocating compressors
  - Axial & radial scroll compliance provides improved liquid handling capability
  - Hermetic design reduces leak potential
- Redesigned suction gas flow results in lower oil circulation and better motor cooling.
- EVI CoreSense Control kits provide advanced features to ensure optimum system operation.



## Compressor protection

- ZF\*KQE and ZFI\*KQE compressors are supplied with internal thermal protectors that prevent motor overheating in case of loss of phase or low refrigerant charge.
- The ZF\*KQE models that operate with liquid injection through DTC Valve in order to control the discharge temperature.
- The ZFI\*KQE models that can operate with Emerson EVI CoreSense control kits in order to control vapor injection superheat as well as a safe discharge temperature.

## Smooth operation

- All Copeland Scroll compressors are designed with a discharge check valve that isolates the high pressure discharge gas. This allows the compressor to start unloaded, resulting in low inrush currents.
- Smooth operations are made possible by the continuous compression process. This generates less vibration than reciprocating technology.

## Delivers unmatched energy efficiency: 5%–20% improvement

- Motor, scroll and bearing redesign minimize annual energy consumption.
- Precision machined scrolls provide the highest isentropic efficiency and wear-in for improved performance over time.
- New valving technology adjusts the scroll compression ratio based on operating condition, significantly improving low ambient performance.
- Using vapor injection improves system capacity by 50% and efficiency by 20% on average at the low temperature rating condition.

## One model for multiple refrigerants

- All ZF and ZFI compressors are qualified for R22, R404A, R507, R407A/C, R407F, R448A and R449A.

Notes: This catalogue only provides performance tables for R22 and R404A. Please visit [Select Software Asia](#) for more information.

## Table of contents

Features and benefits	<b>02</b>
Nomenclature	<b>05</b>
Bill of material	<b>05</b>
Operating envelopes	<b>06</b>
Product line-up	<b>08</b>
Performance data	<b>09</b>
Technical data	<b>26</b>
EVI CoreSense	<b>28</b>
Dimensional drawings	<b>34</b>
Schematic diagram	<b>51</b>
Available models list	<b>52</b>
Accessory list	<b>54</b>
Sound Jacket	<b>58</b>
Contact list	<b>62</b>

# Nomenclature

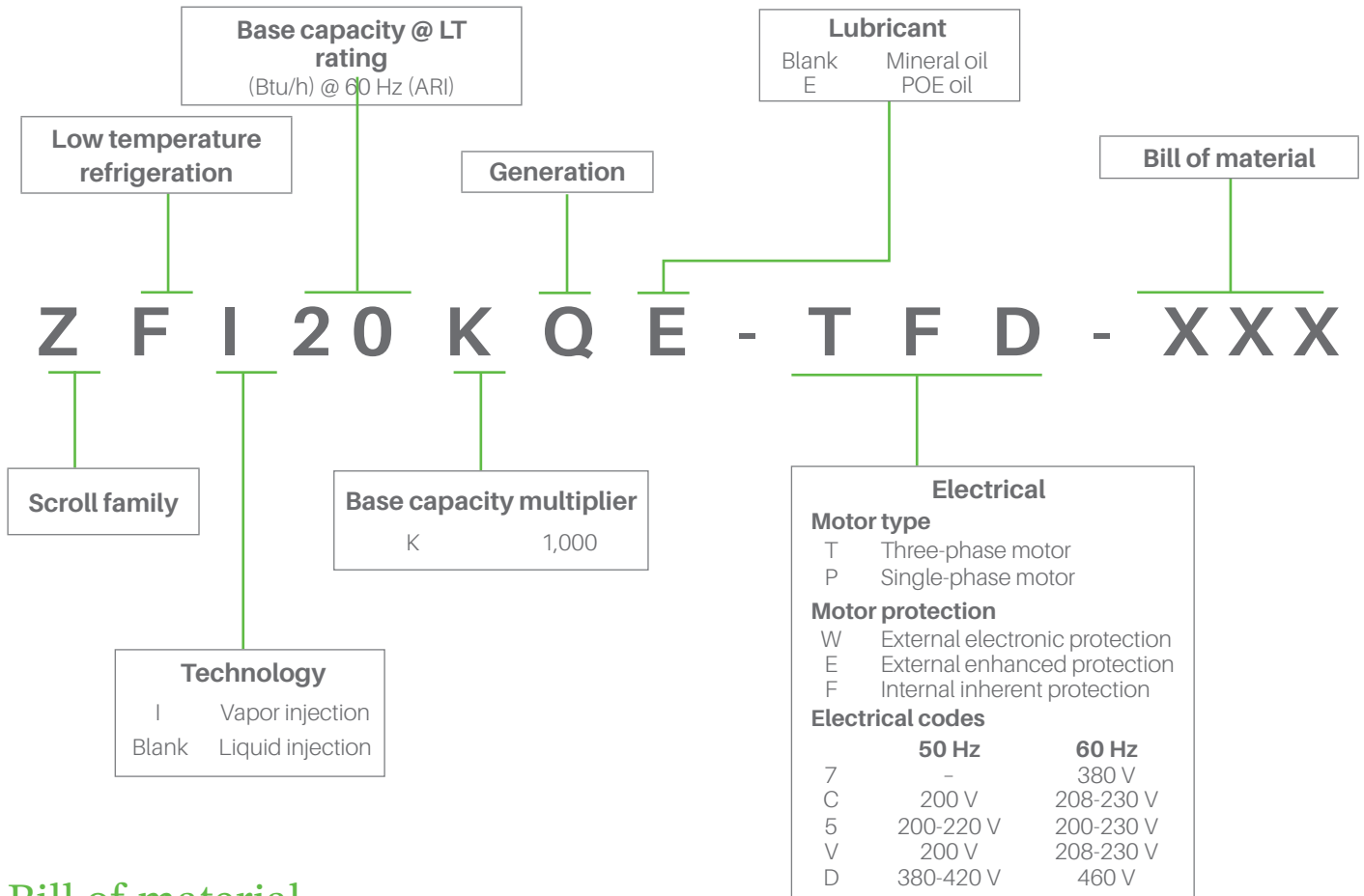

# Bill of material

Compressor model	Motor code	BOM number	Stub tube connection	Rotalock connection	Oil sight glass	Schrader valve
Liquid injection						
ZF06-11KQE	TFD, TF5, PFV	550	✓		✓	✓
		551		✓	✓	✓
ZF13-28KQE	TFD, TF7, TFC <sup>1</sup>	550	✓		✓	✓
		551		✓	✓	✓
ZF28KQE	TFC	580	✓		✓	✓
		591		✓	✓	✓
ZF34-54KQE	TFD, TF7, TFC	554	✓		✓	✓
		564 / 567 <sup>1</sup>		✓	✓	✓
Vapor injection						
ZFI20-39KQE	TFD, TF7, TFC <sup>1</sup>	550	✓		✓	✓
		552		✓	✓	✓
ZFI39KQE	TFC	580	✓		✓	✓
		592		✓	✓	✓
ZFI50-81KQE	TFD, TF7, TFC	554	✓		✓	✓
		564 / 567 <sup>2</sup>		✓	✓	✓
ZFI96-140KQE	TED, TE7, TEC	522	✓		✓	✓
		523		✓	✓	✓

**Remarks:** See technical data sheet for the detailed connection size

ZF06-ZF54KQE only provide rotalock connection to liquid injection fitting for the installation of DTC valve

<sup>1</sup>Except ZF28KQE-TFC and ZFI39KQE-TFC

<sup>2</sup>BOM 554/564 (Sight glass fitting with restriction) only work with Emerson OMB oil management device, BOM567 (Standard sight glass fitting) works with Emerson OM3 in rack application.

# Operating envelopes

# R22

## Vapor injection

ZFI20-26KQE

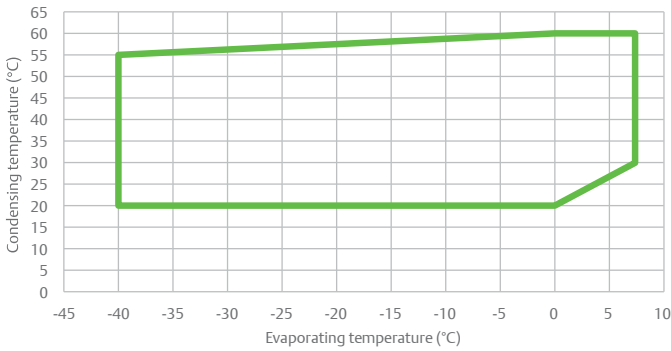

## Liquid injection

ZF06 - 18KQE

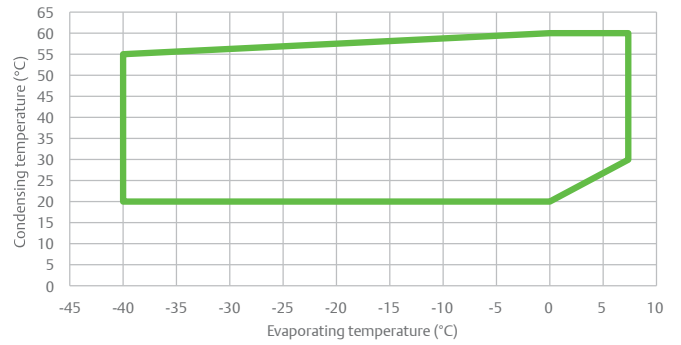

ZFI36-59KQE

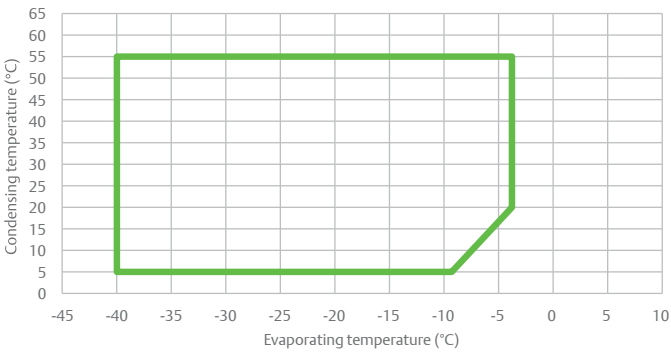

ZF25-41KQE

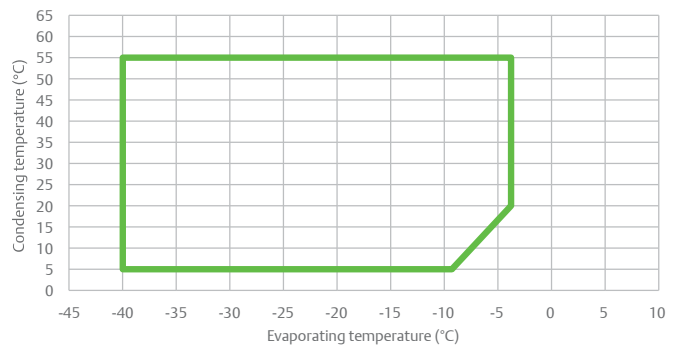

ZFI68-81KQE

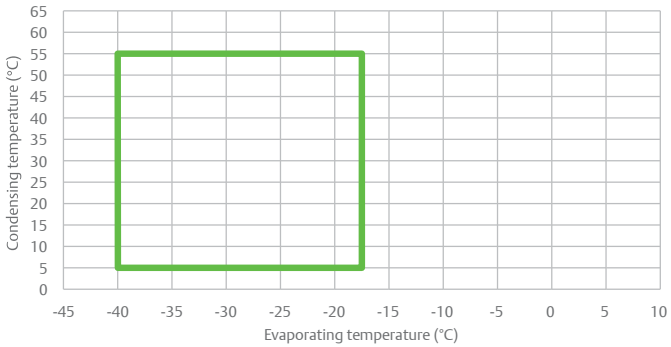

ZF49-54KQE

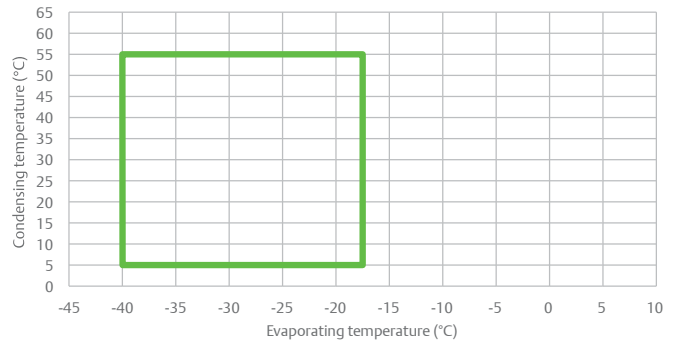

Note: — 20°C return gas + liquid injection

ZFI96-140KQE

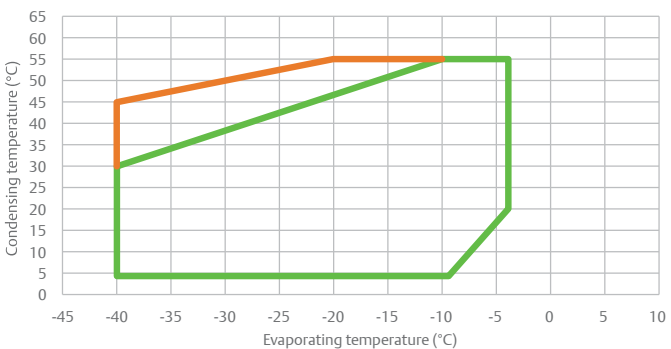

Note: — 20°C Return gas + Vapor injection    — 20K Superheat + Vapor injection

# Operating envelopes

# R404A

## Vapor injection

## Liquid injection

ZFI20 - 26KQE

ZF06 - 18KQE

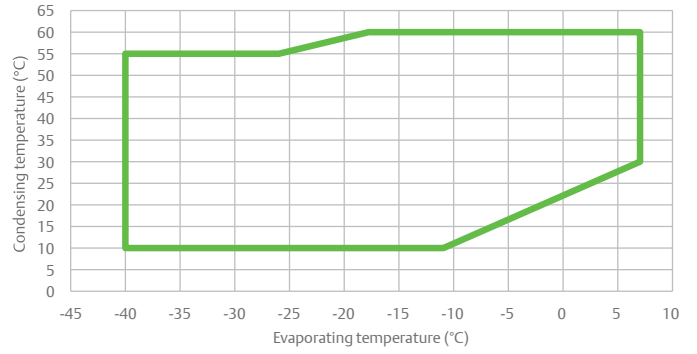
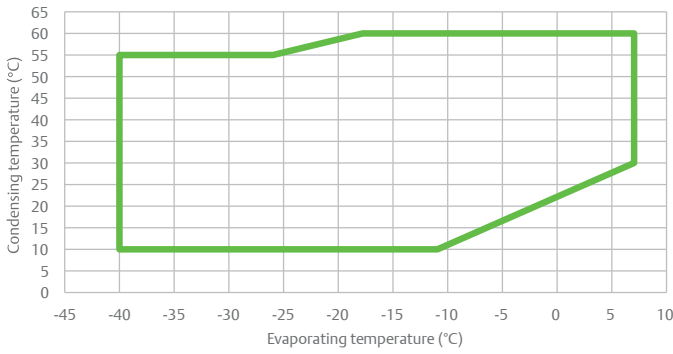

ZFI36 - 59KQE

ZF25 - 41KQE

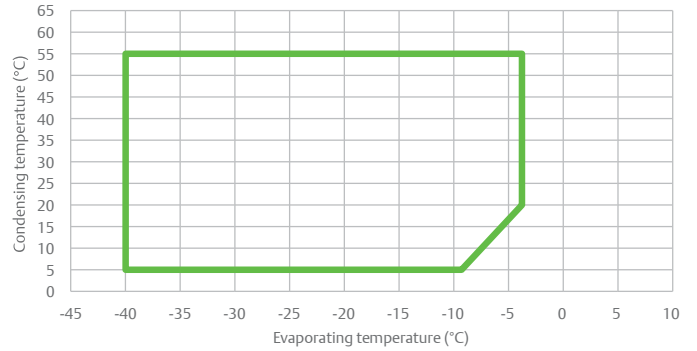
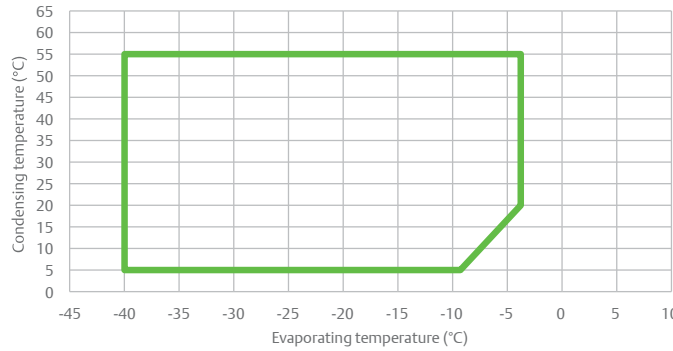

ZFI68-81KQE

ZF49-54KQE

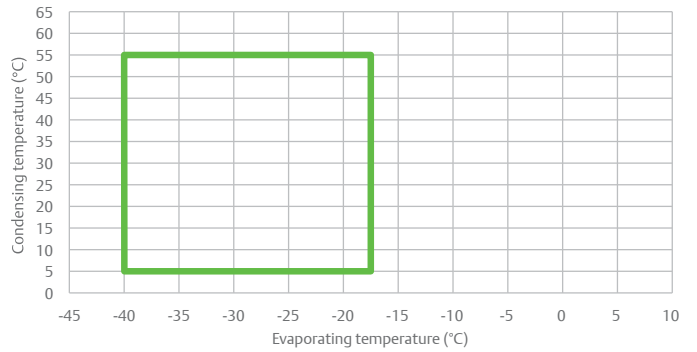
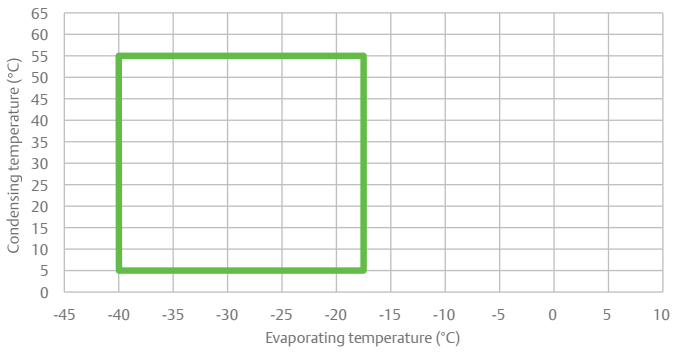

Note: — 20°C return gas + liquid injection

ZFI96-140KQE

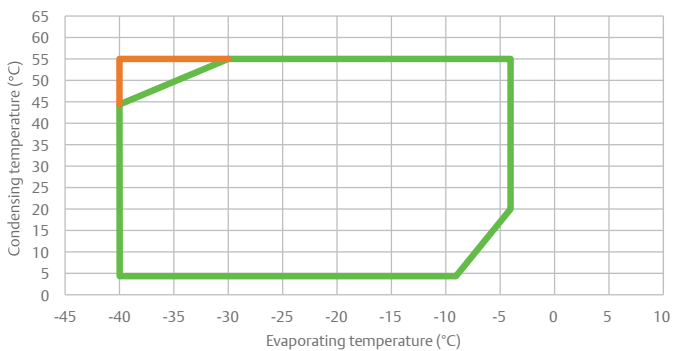

Note: — 20°C Return gas + Vapor injection      — 20K Superheat + Vapor injection

# Product line-up

## R404A - 50 Hz

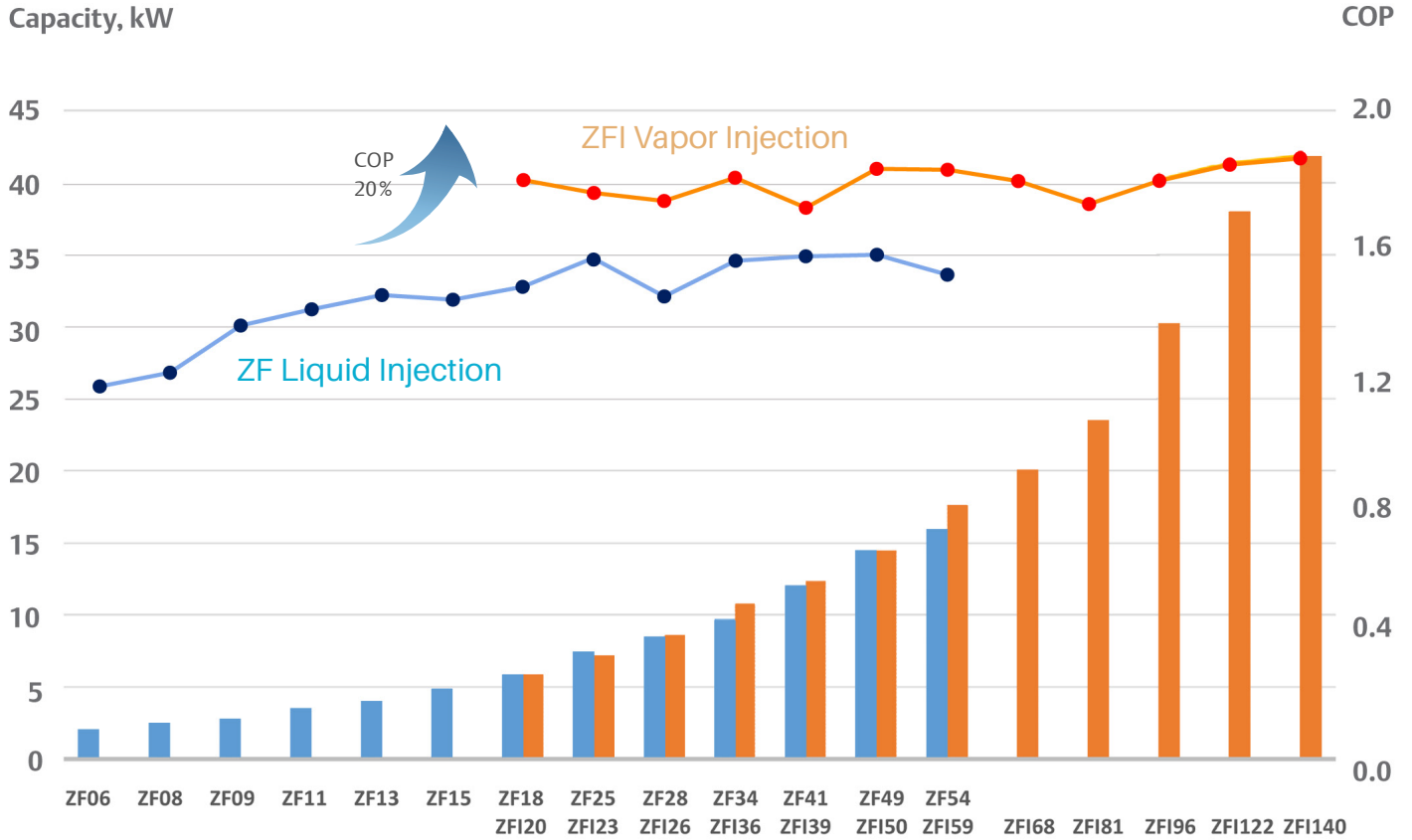

## R404A - 60 Hz

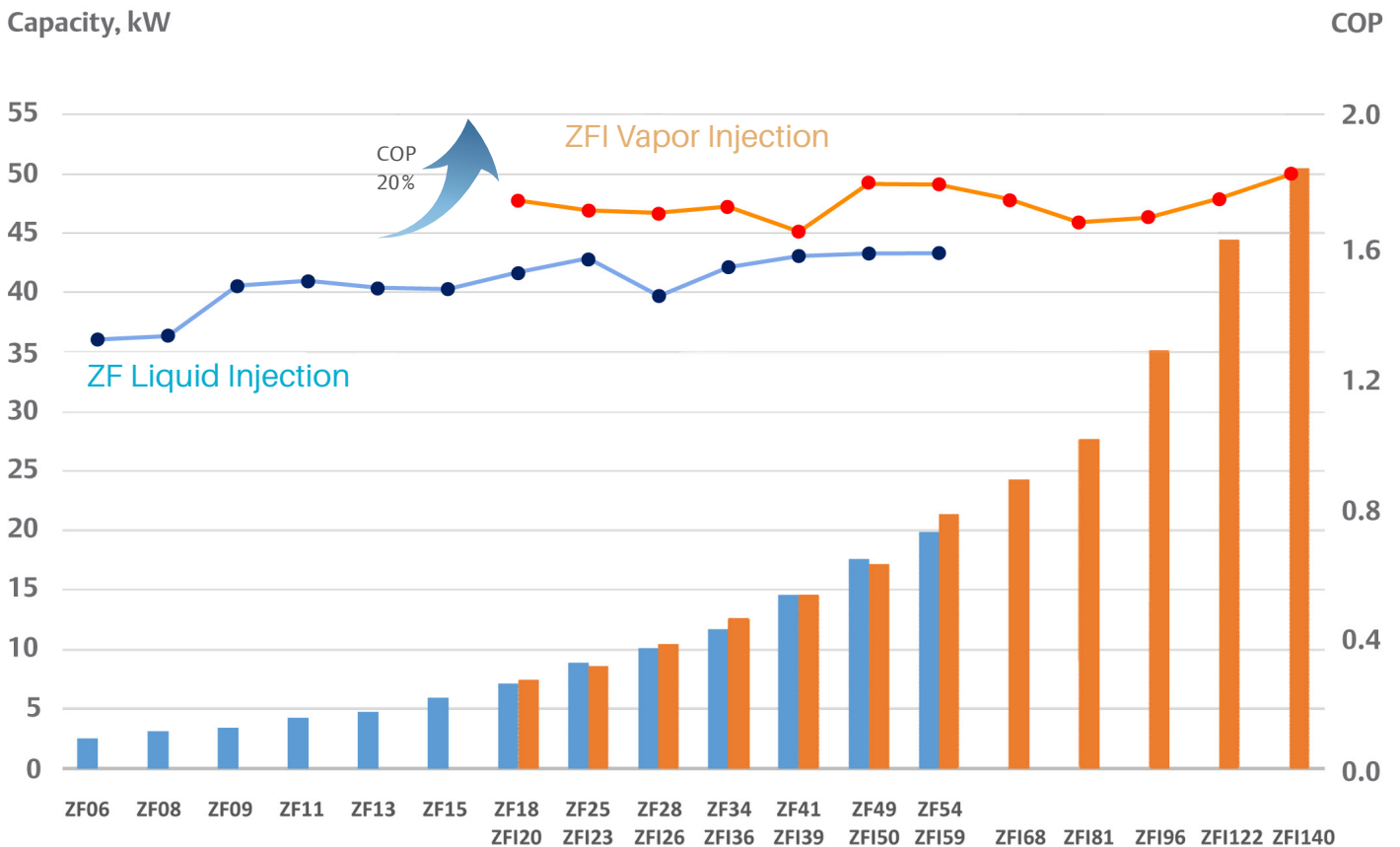

Notes: Based on low temperature cold room conditions: -25°C evaporating, 45°C condensing and 20°C return gas temperature.



# Quick selection

R404A, 50Hz

Model	Nominal HP	Displacement (m <sup>3</sup> /h)	Condensing Temperature 45°C													
			Capacity (kW)							Power (kW)						
			Evaporating Temperature (°C)							Evaporating Temperature (°C)						
			-35	-30	-25	-20	-15	-10	-5	-35	-30	-25	-20	-15	-10	-5
<b>Liquid Injection</b>																
ZF06KQE	2	5.9	1.32	1.65	2.02	2.46	2.97	3.56	4.24	1.60	1.66	1.73	1.80	1.89	1.98	2.09
ZF08KQE	2.5	7.3	1.63	2.03	2.49	3.02	3.65	4.37	5.21	1.91	1.98	2.06	2.15	2.25	2.36	2.49
ZF09KQE	3	8.0	1.80	2.24	2.75	3.34	4.03	4.83	5.76	1.96	1.98	2.03	2.09	2.16	2.25	2.36
ZF11KQE	3.5	10.0	2.28	2.82	3.44	4.16	5.01	6.00	7.16	2.35	2.39	2.45	2.54	2.64	2.75	2.89
ZF13KQE	4	11.7	2.59	3.22	3.97	4.85	5.88	7.06	8.42	2.58	2.65	2.74	2.84	2.95	3.07	3.21
ZF15KQE	5	14.4	3.18	3.96	4.88	5.95	7.20	8.66	10.35	3.10	3.25	3.40	3.55	3.72	3.91	4.11
ZF18KQE	6	17.1	3.88	4.81	5.87	7.12	8.58	10.30	12.35	3.71	3.84	3.98	4.14	4.31	4.50	4.70
ZF25KQE	7.5	21.4	4.78	5.96	7.38	9.01	10.85	12.85	15.05	4.05	4.41	4.73	5.06	5.43	5.86	6.39
ZF28KQE	9	25.1	5.46	6.81	8.44	10.30	12.40	14.70	17.20	5.00	5.44	5.84	6.25	6.70	7.23	7.89
ZF34KQE	10	29.1	6.32	7.92	9.73	11.85	14.25	17.10	20.40	5.58	5.91	6.25	6.58	6.91	7.25	7.58
ZF41KQE	13	35.3	7.96	9.87	12.05	14.55	17.45	20.90	24.90	6.85	7.27	7.68	8.11	8.53	8.97	9.42
ZF49KQE	15	42.4	9.47	11.80	14.50	17.65	-	-	-	8.33	8.73	9.21	9.73	-	-	-
ZF54KQE	17	48.3	10.40	12.95	15.90	19.35	-	-	-	9.49	9.95	10.50	11.10	-	-	-
<b>Vapor Injection</b>																
ZFI20KQE	4	11.7	3.91	4.81	5.85	7.05	8.40	9.96	11.70	3.14	3.20	3.27	3.35	3.42	3.50	3.56
ZFI23KQE	5	14.4	5.31	6.12	7.20	8.53	10.10	11.90	13.90	3.72	3.92	4.10	4.27	4.43	4.57	4.71
ZFI26KQE	6	17.1	6.04	7.18	8.53	10.10	11.95	14.10	16.55	4.50	4.73	4.94	5.13	5.31	5.48	5.63
ZFI36KQE	8	21.4	7.53	9.03	10.75	12.70	14.80	17.15	19.70	5.20	5.61	5.98	6.29	6.56	6.80	7.00
ZFI39KQE	10	25.1	8.64	10.35	12.35	14.55	17.00	19.70	22.60	6.31	6.81	7.25	7.63	7.96	8.24	8.49
ZFI50KQE	12	29.1	9.99	12.05	14.50	17.30	20.40	23.60	27.10	7.11	7.53	7.94	8.32	8.70	9.10	9.52
ZFI59KQE	15	35.3	12.15	14.70	17.65	21.10	24.80	28.80	33.00	8.67	9.19	9.68	10.15	10.60	11.10	11.60
ZFI68KQE	18	42.4	13.80	16.65	20.10	23.90	-	-	-	10.10	10.70	11.25	11.80	-	-	-
ZFI81KQE	20	48.3	16.20	19.50	23.50	28.00	-	-	-	12.25	13.00	13.70	14.35	-	-	-
ZFI96KQE	25	60.7	20.60	25.10	30.20	36.00	42.80	50.70	59.80	15.55	16.25	16.90	17.60	18.30	19.00	19.85
ZFI122KQE	30	77.3	26.00	31.60	38.00	45.40	53.90	63.80	75.40	18.95	19.80	20.60	21.40	22.30	23.20	24.20
ZFI140KQE	40	87.5	28.50	34.70	41.80	50.00	59.60	70.60	83.50	20.70	21.70	22.50	23.40	24.30	25.30	26.40

R404A, 60Hz

Model	Nominal HP	Displacement (m <sup>3</sup> /h)	Condensing Temperature 45°C													
			Capacity (kW)							Power (kW)						
			Evaporating Temperature (°C)							Evaporating Temperature (°C)						
			-35	-30	-25	-20	-15	-10	-5	-35	-30	-25	-20	-15	-10	-5
<b>Liquid Injection</b>																
ZF06KQE	2	7.1	1.56	1.94	2.38	2.88	3.46	4.13	4.92	1.73	1.76	1.82	1.91	2.02	2.15	2.27
ZF08KQE	2.5	8.8	1.97	2.45	3.01	3.66	4.41	5.29	6.30	2.16	2.21	2.28	2.38	2.49	2.62	2.77
ZF09KQE	3	9.7	2.20	2.73	3.34	4.04	4.87	5.83	6.96	2.15	2.20	2.27	2.36	2.48	2.61	2.76
ZF11KQE	3.5	12.1	2.74	3.39	4.16	5.05	6.10	7.30	8.70	2.60	2.69	2.80	2.93	3.09	3.27	3.47
ZF13KQE	4	14.1	3.07	3.83	4.74	5.80	7.03	8.44	10.05	3.05	3.13	3.23	3.36	3.52	3.70	3.92
ZF15KQE	5	17.4	3.86	4.79	5.87	7.14	8.62	10.35	12.35	3.65	3.83	4.01	4.21	4.43	4.67	4.95
ZF18KQE	6	20.6	4.72	5.83	7.10	8.60	10.35	12.40	14.80	4.32	4.48	4.69	4.95	5.24	5.56	5.90
ZF25KQE	7.5	25.8	5.80	7.18	8.85	10.80	13.15	15.85	18.90	4.77	5.24	5.68	6.09	6.49	6.89	7.28
ZF28KQE	9	30.3	6.62	8.20	10.10	12.35	15.00	18.10	21.60	5.88	6.46	7.00	7.52	8.01	8.50	8.98
ZF34KQE	10	35.1	7.57	9.48	11.65	14.15	17.05	20.50	24.40	6.79	7.20	7.61	8.01	8.42	8.82	9.23
ZF41KQE	13	42.6	9.59	11.90	14.50	17.55	21.00	25.20	30.00	8.25	8.75	9.26	9.77	10.30	10.80	11.35
ZF49KQE	15	51.2	11.40	14.20	17.45	21.20	-	-	-	10.05	10.50	11.10	11.70	-	-	-
ZF54KQE	17	58.3	13.00	16.20	19.90	24.20	-	-	-	11.45	12.00	12.65	13.35	-	-	-
<b>Vapor Injection</b>																
ZFI20KQE	4	14.1	5.07	6.13	7.34	8.72	10.30	12.10	14.15	3.78	3.95	4.12	4.27	4.41	4.54	4.66
ZFI23KQE	5	17.4	6.32	7.28	8.57	10.15	12.00	14.15	16.55	4.39	4.63	4.84	5.04	5.22	5.40	5.55
ZFI26KQE	6	20.6	7.25	8.77	10.45	12.35	14.50	16.90	19.70	5.31	5.66	6.00	6.32	6.63	6.93	7.23
ZFI36KQE	8	25.8	9.02	10.70	12.65	15.00	17.85	21.20	25.20	6.26	6.74	7.19	7.63	8.09	8.59	9.17
ZFI39KQE	10	30.3	10.40	12.30	14.55	17.25	20.50	24.40	28.90	7.50	8.08	8.62	9.15	9.70	10.30	11.00
ZFI50KQE	12	35.1	11.85	14.25	17.15	20.50	24.10	28.00	32.00	8.40	8.90	9.37	9.83	10.30	10.75	11.25
ZFI59KQE	15	42.6	14.65	17.70	21.30	25.40	29.90	34.70	39.70	10.45	11.10	11.65	12.25	12.80	13.35	14.00
ZFI68KQE	18	51.2	16.55	20.00	24.10	28.70	-	-	-	12.10	12.85	13.50	14.15	-	-	-
ZFI81KQE	20	58.3	19.05	23.00	27.60	33.00	-	-	-	14.45	15.30	16.10	16.90	-	-	-
ZFI96KQE	25	73.3	24.00	29.30	35.20	42.00	49.90	59.10	69.80	18.75	19.60	20.40	21.20	22.10	23.00	24.00
ZFI122KQE	30	93.3	30.30	36.90	44.40	53.00	62.90	74.50	88.00	22.90	23.90	24.90	25.90	26.90	28.00	29.20
ZFI140KQE	40	105.5	34.40	41.80	50.40	60.20	71.70	85.10	100.50	24.90	26.00	27.10	28.10	29.20	30.30	31.60

Condition: 20°C return gas, 0K subcooling

# Performance data

TFC: 200 V, 3-Phase, 50 Hz ; TFD: 380-420 V, 3-Phase, 50 Hz

## Liquid injection

# R22

Model			Cond. temp. °C	Evap. temp. °C										
				-40	-35	-30	-25	-20	-15	-10	-5	0	5	7
ZF06KQE	TF5 TFD	Q	30	1.15	1.46	1.82	2.24	2.73	3.31	3.98	4.74	5.62	6.61	7.05
			40	1.05	1.34	1.67	2.06	2.52	3.05	3.66	4.37	5.18	6.10	6.50
			50	0.97	1.23	1.53	1.88	2.29	2.77	3.32	3.96	4.70	5.55	5.91
	P	30	1.21	1.24	1.29	1.34	1.40	1.47	1.55	1.65	1.76	1.89	1.95	
		40	1.43	1.47	1.52	1.58	1.64	1.70	1.78	1.87	1.98	2.10	2.15	
		50	1.69	1.74	1.79	1.85	1.92	1.99	2.06	2.15	2.25	2.36	2.41	
ZF08KQE	TF5 TFD	Q	30	1.41	1.79	2.23	2.75	3.36	4.07	4.89	5.83	6.91	8.13	8.66
			40	1.29	1.65	2.06	2.54	3.10	3.75	4.50	5.37	6.36	7.50	7.99
			50	1.19	1.52	1.89	2.32	2.82	3.40	4.09	4.87	5.78	6.82	7.27
	P	30	1.44	1.48	1.54	1.60	1.67	1.75	1.85	1.96	2.10	2.25	2.32	
		40	1.70	1.76	1.81	1.88	1.95	2.03	2.12	2.23	2.35	2.50	2.56	
		50	2.01	2.07	2.14	2.21	2.28	2.36	2.46	2.56	2.68	2.81	2.87	
ZF09KQE	TF5 TFD	Q	30	1.59	2.01	2.50	3.09	3.78	4.58	5.51	6.58	7.79	9.17	9.77
			40	1.46	1.85	2.30	2.84	3.48	4.22	5.07	6.06	7.18	8.46	9.01
			50	1.34	1.69	2.11	2.59	3.16	3.83	4.60	5.50	6.52	7.69	8.20
	P	30	1.52	1.57	1.61	1.67	1.72	1.79	1.86	1.94	2.04	2.15	2.19	
		40	1.80	1.85	1.90	1.95	2.01	2.07	2.14	2.22	2.31	2.41	2.45	
		50	2.10	2.16	2.22	2.28	2.34	2.41	2.48	2.56	2.65	2.75	2.79	
ZF11KQE	TF5 TFD	Q	30	1.97	2.49	3.10	3.82	4.67	5.65	6.78	8.07	9.54	11.20	11.91
			40	1.81	2.29	2.86	3.52	4.30	5.21	6.26	7.47	8.84	10.39	11.06
			50	1.65	2.08	2.59	3.19	3.89	4.72	5.67	6.78	8.04	9.47	10.09
	P	30	1.69	1.74	1.81	1.88	1.97	2.08	2.20	2.34	2.50	2.67	2.74	
		40	2.00	2.06	2.13	2.21	2.30	2.40	2.52	2.65	2.80	2.97	3.04	
		50	2.37	2.44	2.51	2.59	2.69	2.79	2.91	3.04	3.19	3.35	3.42	
ZF13KQE	TFC TFD	Q	30	2.30	2.89	3.60	4.44	5.44	6.60	7.94	9.48	11.23	13.21	14.07
			40	2.12	2.66	3.32	4.09	5.01	6.07	7.31	8.73	10.34	12.17	12.97
			50	1.93	2.43	3.02	3.72	4.55	5.51	6.63	7.93	9.41	11.08	11.82
	P	30	2.02	2.08	2.15	2.23	2.31	2.41	2.51	2.62	2.74	2.87	2.93	
		40	2.38	2.45	2.52	2.61	2.70	2.81	2.92	3.04	3.17	3.31	3.37	
		50	2.79	2.86	2.94	3.04	3.14	3.26	3.38	3.51	3.65	3.80	3.87	
ZF15KQE	TFC TFD	Q	30	2.79	3.52	4.39	5.42	6.63	8.03	9.63	11.47	13.54	15.87	16.87
			40	2.57	3.25	4.05	5.01	6.12	7.42	8.91	10.62	12.55	14.73	15.68
			50	2.34	2.95	3.68	4.54	5.56	6.74	8.11	9.68	11.46	13.48	14.35
	P	30	2.47	2.53	2.61	2.70	2.82	2.95	3.11	3.29	3.52	3.78	3.89	
		40	2.89	2.97	3.06	3.15	3.27	3.40	3.55	3.74	3.95	4.19	4.30	
		50	3.38	3.47	3.58	3.68	3.81	3.94	4.10	4.28	4.49	4.73	4.83	
ZF18KQE	TFC TFD	Q	30	3.25	4.12	5.17	6.42	7.89	9.60	11.58	13.84	16.41	19.31	20.57
			40	2.98	3.78	4.75	5.90	7.25	8.82	10.64	12.73	15.11	17.80	18.97
			50	2.69	3.42	4.30	5.34	6.56	7.99	9.65	11.55	13.73	16.20	17.27
	P	30	3.13	3.18	3.25	3.33	3.43	3.55	3.69	3.86	4.05	4.27	4.36	
		40	3.68	3.75	3.82	3.91	4.02	4.14	4.29	4.46	4.65	4.86	4.96	
		50	4.31	4.39	4.49	4.60	4.72	4.86	5.02	5.20	5.40	5.62	5.72	

### Notes:

1. Q for capacity; P for power. Units in kW

2. All ZF\*KQE values are rated at return gas temperature: 20°C and subcooling: 0 K

# Performance data

TFC: 200 V, 3-Phase, 50 Hz ; TFD: 380-420 V, 3-Phase, 50 Hz

Liquid injection

# R22

Model			Cond. temp. °C	Evap. temp. °C										
				-40	-35	-30	-25	-20	-15	-10	-5	0	5	7
ZF25KQE	TFC TFD	Q	30	4.08	5.17	6.48	8.04	9.89	12.04	14.52	17.35			
			40	3.73	4.74	5.95	7.39	9.09	11.06	13.34	15.96			
			50	3.37	4.29	5.39	6.69	8.22	10.02	12.09	14.48			
		P	30	3.93	3.99	4.07	4.17	4.30	4.45	4.63	4.84			
			40	4.62	4.70	4.79	4.90	5.04	5.19	5.38	5.59			
			50	5.40	5.50	5.62	5.76	5.92	6.09	6.29	6.52			
ZF28KQE	TFC TFD	Q	30	4.79	6.07	7.61	9.45	11.62	14.14	17.06	20.39			
			40	4.39	5.57	7.00	8.69	10.68	13.00	15.68	18.76			
			50	3.96	5.04	6.33	7.86	9.66	11.77	14.21	17.02			
		P	30	4.72	4.79	4.88	5.01	5.16	5.34	5.55	5.80			
			40	5.54	5.63	5.75	5.88	6.04	6.23	6.45	6.70			
			50	6.48	6.61	6.75	6.91	7.10	7.31	7.55	7.82			
ZF34KQE	TFC TFD	Q	30	5.31	6.77	8.52	10.59	13.01	15.82	19.06	22.74			
			40	4.81	6.19	7.83	9.75	12.00	14.59	17.58	20.99			
			50	4.22	5.51	7.03	8.79	10.84	13.22	15.95	19.06			
		P	30	4.32	4.50	4.68	4.87	5.06	5.26	5.46	5.66			
			40	4.95	5.21	5.46	5.71	5.95	6.19	6.42	6.64			
			50	5.67	6.02	6.36	6.68	6.98	7.27	7.53	7.77			
ZF41KQE	TFC TFD	Q	30	6.35	8.03	10.03	12.41	15.21	18.48	22.26	26.61			
			40	5.80	7.40	9.27	11.46	14.03	17.01	20.46	24.42			
			50	5.09	6.61	8.36	10.38	12.72	15.43	18.56	22.15			
		P	30	5.24	5.49	5.75	6.01	6.27	6.53	6.80	7.06			
			40	6.05	6.38	6.71	7.03	7.35	7.66	7.97	8.27			
			50	6.95	7.36	7.76	8.16	8.53	8.90	9.26	9.61			
ZF49KQE	TFC TFD	Q	30	7.81	9.82	12.30	15.28	18.78						
			40	7.10	8.99	11.31	14.08	17.33						
			50	6.23	8.00	10.16	12.72	15.71						
		P	30	6.48	6.68	6.94	7.25	7.59						
			40	7.52	7.76	8.08	8.45	8.86						
			50	8.78	9.07	9.43	9.86	10.32						
ZF54KQE	TFC TFD	Q	30	8.99	11.36	14.18	17.49	21.36						
			40	8.31	10.54	13.16	16.23	19.82						
			50	7.50	9.56	11.96	14.78	18.06						
		P	30	4.26	4.73	5.16	5.62	6.14						
			40	5.54	6.02	6.48	6.95	7.47						
			50	7.25	7.80	8.31	8.83	9.40						

**Notes:**

1. Q for capacity; P for power. Units in kW
2. All ZF\*KQE values are rated at return gas temperature: 20°C and subcooling: 0 K

# Performance data

TFC: 200 V, 3-Phase, 50 Hz; TFD: 380-420 V, 3-Phase, 50 Hz

Vapor injection

# R22

Model			Cond. temp. °C	Evap. temp. °C										
				-40	-35	-30	-25	-20	-15	-10	-5	0	5	7
ZFI20KQE	Q	TFC	30	2.56	3.22	4.01	4.94	6.00	7.18	8.47	9.87	11.37	12.97	13.64
			40	2.55	3.21	3.99	4.90	5.93	7.06	8.30	9.63	11.06	12.56	13.18
			50	2.32	2.99	3.78	4.68	5.68	6.78	7.97	9.24	10.59	12.01	12.60
	P	TFD	30	2.14	2.18	2.27	2.39	2.55	2.72	2.91	3.09	3.28	3.45	3.51
			40	2.39	2.50	2.63	2.76	2.90	3.02	3.13	3.22	3.26	3.27	3.26
			50	2.98	3.13	3.27	3.39	3.48	3.53	3.53	3.48	3.37	3.18	3.09
	LO		30	-7.70	-6.20	-4.40	-1.80	1.30	4.90	8.80	12.80	16.70	20.60	22.00
			40	-4.90	-3.60	-1.70	0.90	4.30	8.10	12.20	16.30	20.40	24.40	25.90
			50	3.60	2.60	3.10	5.00	7.90	11.60	15.60	19.80	23.90	28.00	29.50
ZFI23KQE	Q	TFC	30	3.46	4.39	5.48	6.74	8.19	9.84	11.75	13.85	16.25	18.90	20.10
			40	3.36	4.28	5.34	6.55	7.93	9.50	11.30	13.30	15.55	18.10	19.15
			50	3.19	4.10	5.12	6.28	7.60	9.09	10.80	12.70	14.80	17.20	18.20
	P	TFD	30	2.48	2.56	2.65	2.75	2.87	3.01	3.18	3.39	3.63	3.92	4.05
			40	2.97	3.10	3.21	3.34	3.46	3.60	3.76	3.95	4.17	4.42	4.53
			50	3.58	3.75	3.91	4.06	4.21	4.36	4.52	4.70	4.90	5.13	5.23
	LO		30	-13.10	-14.70	-16.20	-16.20	-14.40	-11.00	-6.40	-1.30	3.90	9.00	11.00
			40	-17.30	-14.70	-13.90	-12.90	-10.70	-7.40	-3.20	1.60	6.50	11.40	13.20
			50	-12.30	-6.10	-3.90	-2.50	-0.70	1.80	5.10	8.90	13.00	17.00	18.60
ZFI26KQE	Q	TFC	30	3.85	4.79	5.97	7.36	8.94	10.66	12.51	14.45	16.45	18.49	19.30
			40	3.79	4.73	5.89	7.25	8.78	10.45	12.22	14.07	15.96	17.87	18.63
			50	3.44	4.38	5.55	6.89	8.38	9.99	11.70	13.47	15.26	17.06	17.77
	P	TFD	30	2.98	3.08	3.21	3.36	3.57	3.84	4.19	4.65	5.21	5.91	6.23
			40	3.37	3.57	3.75	3.92	4.10	4.31	4.56	4.86	5.24	5.70	5.91
			50	4.23	4.49	4.69	4.84	4.95	5.05	5.15	5.26	5.41	5.60	5.69
	LO		30	-5.40	-3.40	-1.70	0.50	3.50	7.20	11.50	16.20	21.10	26.10	28.10
			40	-2.20	-0.40	1.20	3.50	6.60	10.50	15.00	19.80	24.80	29.90	32.00
			50	6.20	5.90	6.20	7.70	10.40	14.10	18.50	23.30	28.40	33.60	35.60
ZFI36KQE	Q	TFC	30	5.37	6.66	8.04	9.62	11.52	13.85	16.72	20.25			
			40	5.00	6.28	7.63	9.17	11.02	13.29	16.09	19.54			
			50	4.41	5.65	6.96	8.44	10.22	12.42	15.13	18.49			
	P	TFD	30	3.08	3.38	3.73	4.11	4.51	4.90	5.29	5.64			
			40	4.00	4.27	4.57	4.90	5.24	5.57	5.88	6.16			
			50	5.64	5.82	6.03	6.27	6.51	6.73	6.93	7.09			
	LO		30	-12.40	-11.80	-7.70	-3.60	-0.90	-0.30	-1.70	-5.00			
			40	-2.20	-3.10	0.10	3.60	5.80	6.10	4.40	0.90			
			50	5.20	3.80	6.80	10.30	12.40	12.60	10.80	7.20			
ZFI39KQE	Q	TFC	30	6.15	7.66	9.25	11.06	13.23	15.92	19.27	23.43			
			40	5.74	7.22	8.77	10.54	12.66	15.28	18.55	22.62			
			50	5.07	6.51	8.00	9.70	11.74	14.28	17.46	21.42			
	P	TFD	30	3.50	3.78	4.16	4.60	5.06	5.47	5.80	6.01			
			40	4.50	4.75	5.10	5.49	5.87	6.22	6.46	6.57			
			50	6.32	6.49	6.74	7.02	7.30	7.51	7.62	7.58			
	LO		30	-19.40	-14.90	-10.50	-6.90	-4.30	-3.00	-2.90	-3.80			
			40	-6.70	-5.20	-2.40	0.40	2.50	3.50	3.40	2.30			
			50	2.00	2.10	4.50	7.20	9.20	10.20	10.10	9.00			

**Notes:**

1. Q for capacity, P for power. Units in kW; LO for liquid out temperature in °C
2. All ZF\*KQE values are rated at return gas temperature: 20°C and max subcooling
3.  20K Superheat

# Performance data

TFC: 200 V, 3-Phase, 50 Hz ; TFD: 380-420 V, 3-Phase, 50 Hz

Vapor injection

# R22

Model		Cond. temp. °C	Evap. temp. °C											
			-40	-35	-30	-25	-20	-15	-10	-5	0	5	7	
ZFI59KQE	TFC	Q	30	8.79	10.88	13.11	15.67	18.75	22.54	27.23	32.99			
			40	8.19	10.25	12.43	14.93	17.94	21.63	26.19	31.81			
			50	7.19	9.20	11.32	13.74	16.64	20.21	24.63	30.10			
	TFD	P	30	5.07	5.37	5.91	6.57	7.23	7.76	8.05	7.97			
			40	6.45	6.73	7.23	7.83	8.40	8.83	8.98	8.74			
			50	9.02	9.20	9.58	10.03	10.43	10.66	10.60	10.12			
	LO	30	-11.60	-9.20	-5.00	-1.20	1.30	2.20	1.40	-0.70				
		40	-0.50	-0.20	2.70	5.80	7.80	8.40	7.50	5.10				
		50	7.30	6.60	9.30	12.30	14.30	14.90	13.90	11.50				
ZFI68KQE	TFC	Q	30	10.54	12.93	15.57	18.63	22.31						
			40	9.77	12.15	14.76	17.76	21.34						
			50	8.55	10.90	13.44	16.35	19.81						
	TFD	P	30	5.92	6.38	7.04	7.79	8.56						
			40	7.61	8.03	8.62	9.29	9.95						
			50	10.69	10.97	11.40	11.89	12.35						
	LO	30	-9.50	-8.30	-4.20	-0.20	2.30							
		40	0.70	0.30	3.30	6.70	8.80							
		50	8.20	7.10	10.00	13.20	15.20							
ZFI96KQE	TEC	Q	30	15.70	18.80	22.70	27.50	33.50	40.70	49.30	59.40			
			40	15.40	18.70	22.50	26.50	31.70	38.00	45.30	53.80			
			50			21.10	25.30	30.00	35.40	41.40	48.50			
	TED	P	30	9.74	10.20	10.70	11.25	11.85	12.60	13.40	14.35			
			40	12.30	12.85	13.40	13.80	14.40	15.05	15.75	16.55			
			50			16.60	17.20	17.75	18.35	18.90	19.60			
	LO	30	-20.50	-9.30	-1.90	2.60	4.80	5.50	5.10	3.70				
		40	-6.70	-3.50	1.70	7.00	11.60	15.10	17.50	18.80				
		50			9.50	13.40	18.80	24.10	28.60	32.10				
ZFI122KQE	TEC	Q	30	19.81	23.68	28.57	34.68	42.18	51.26	62.10	74.88			
			40	19.42	23.58	28.34	33.36	40.00	47.83	57.05	67.82			
			50			26.57	31.90	37.83	44.57	52.15	61.16			
	TED	P	30	11.73	12.30	12.90	13.56	14.30	15.14	16.12	17.26			
			40	14.80	15.48	16.12	16.60	17.33	18.11	18.97	19.94			
			50			20.01	20.72	21.40	21.99	22.76	23.58			
	LO	30	-20.50	-9.30	-1.90	2.60	4.90	5.50	5.10	3.70				
		40	-6.70	-3.50	1.70	7.00	11.60	15.10	17.50	18.90				
		50			9.50	13.50	18.80	24.10	28.60	32.10				
ZFI140KQE	TEC	Q	30	22.80	27.30	32.90	40.00	48.60	59.00	71.50	86.20			
			40	22.40	27.20	32.60	38.40	46.00	55.00	65.60	78.00			
			50			30.50	36.70	43.50	50.90	59.90	70.30			
	TED	P	30	12.80	13.40	14.05	14.75	15.60	16.50	17.55	18.80			
			40	16.15	16.90	17.60	18.10	18.90	19.75	20.70	21.70			
			50			21.80	22.60	23.30	24.00	24.80	25.70			
	LO	30	-22.70	-11.60	-4.10	0.50	3.00	3.80	3.30	2.00				
		40	-8.60	-5.50	-0.20	5.40	10.10	13.70	16.10	17.40				
		50			8.00	12.10	17.60	23.00	27.50	30.90				

**Notes:**

1. Q for capacity, P for power. Units in kW; LO for liquid out temperature in °C
2. All ZF\*KQE values are rated at return gas temperature: 20°C and max subcooling
3.  20K Superheat

# Performance data

TF7: 380 V, 3-Phase, 60 Hz ; TFC: 208-230 V, 3-Phase, 60 Hz ; TFD: 460 V, 3-Phase, 60 Hz

## Liquid injection

# R22

Model			Cond. temp. °C	Evap. temp. °C										
				-40	-35	-30	-25	-20	-15	-10	-5	0	5	7
ZF06KQE	TF5 TFD	Q	30	1.32	1.66	2.08	2.59	3.18	3.87	4.66	5.54	6.54	7.64	8.11
			40	1.23	1.55	1.94	2.42	2.97	3.61	4.35	5.17	6.10	7.13	7.57
			50	1.15	1.44	1.80	2.23	2.73	3.32	3.99	4.75	5.59	6.54	6.94
	P	30	1.31	1.35	1.39	1.44	1.49	1.56	1.65	1.75	1.88	2.05	2.12	
		40	1.57	1.60	1.64	1.67	1.71	1.77	1.85	1.95	2.07	2.23	2.30	
		50	1.90	1.92	1.94	1.96	2.00	2.05	2.12	2.21	2.33	2.48	2.55	
ZF08KQE	TF5 TFD	Q	30	1.68	2.11	2.64	3.29	4.04	4.92	5.92	7.05	8.31	9.71	10.31
			40	1.57	1.97	2.47	3.07	3.78	4.60	5.53	6.58	7.76	9.06	9.62
			50	1.46	1.83	2.29	2.83	3.47	4.22	5.07	6.03	7.11	8.31	8.83
	P	30	1.63	1.68	1.73	1.79	1.86	1.94	2.05	2.18	2.34	2.55	2.64	
		40	1.96	2.00	2.03	2.08	2.13	2.20	2.30	2.42	2.58	2.77	2.86	
		50	2.36	2.39	2.41	2.44	2.49	2.55	2.63	2.75	2.89	3.08	3.17	
ZF09KQE	TF5 TFD	Q	30	1.92	2.43	3.03	3.74	4.56	5.52	6.64	7.92	9.38	11.04	11.77
			40	1.76	2.24	2.80	3.45	4.20	5.09	6.11	7.29	8.65	10.19	10.86
			50	1.62	2.06	2.56	3.14	3.83	4.62	5.55	6.62	7.85	9.26	9.87
	P	30	1.64	1.69	1.75	1.82	1.91	2.00	2.11	2.25	2.40	2.58	2.66	
		40	1.95	2.01	2.07	2.15	2.23	2.32	2.43	2.55	2.69	2.86	2.93	
		50	2.30	2.37	2.44	2.52	2.61	2.70	2.81	2.93	3.07	3.22	3.29	
ZF11KQE	TF5 TFD	Q	30	2.38	3.01	3.75	4.62	5.63	6.81	8.16	9.70	11.46	13.44	14.30
			40	2.18	2.76	3.45	4.25	5.19	6.28	7.54	8.99	10.63	12.50	13.31
			50	1.98	2.51	3.12	3.84	4.69	5.68	6.83	8.16	9.68	11.40	12.16
	P	30	1.82	1.89	1.98	2.09	2.22	2.37	2.54	2.75	2.97	3.23	3.34	
		40	2.16	2.24	2.33	2.44	2.57	2.72	2.89	3.08	3.29	3.53	3.63	
		50	2.57	2.66	2.77	2.88	3.01	3.16	3.32	3.51	3.71	3.94	4.04	
ZF13KQE	TF7 TFC TFD	Q	30	2.75	3.46	4.33	5.35	6.56	7.96	9.57	11.41	13.49	15.83	16.84
			40	2.54	3.20	3.99	4.94	6.04	7.33	8.81	10.51	12.43	14.60	15.54
			50	2.30	2.90	3.62	4.48	5.48	6.65	8.00	9.55	11.31	13.31	14.17
	P	30	2.17	2.29	2.41	2.53	2.64	2.75	2.85	2.95	3.04	3.12	3.14	
		40	2.55	2.67	2.80	2.94	3.08	3.22	3.37	3.53	3.68	3.83	3.90	
		50	2.97	3.08	3.21	3.36	3.52	3.70	3.88	4.09	4.30	4.52	4.61	
ZF15KQE	TF7 TFC TFD	Q	30	3.38	4.27	5.32	6.57	8.02	9.70	11.63	13.82	16.29	19.06	20.25
			40	3.12	3.94	4.92	6.07	7.41	8.97	10.76	12.80	15.11	17.70	18.82
			50	2.83	3.57	4.46	5.50	6.73	8.15	9.79	11.67	13.80	16.20	17.24
	P	30	2.75	2.84	2.95	3.08	3.25	3.45	3.68	3.96	4.28	4.64	4.80	
		40	3.21	3.32	3.44	3.58	3.74	3.94	4.16	4.42	4.73	5.07	5.22	
		50	3.75	3.87	4.01	4.16	4.33	4.53	4.76	5.01	5.30	5.63	5.77	
ZF18KQE	TF7 TFC TFD	Q	30	3.96	5.02	6.28	7.79	9.56	11.63	14.01	16.75	19.86	23.37	24.89
			40	3.65	4.62	5.79	7.17	8.79	10.68	12.87	15.39	18.26	21.50	22.91
			50	3.31	4.20	5.26	6.51	7.97	9.69	11.68	13.97	16.59	19.57	20.86
	P	30	3.38	3.43	3.52	3.66	3.83	4.03	4.23	4.44	4.63	4.81	4.88	
		40	3.94	4.01	4.12	4.29	4.48	4.70	4.94	5.18	5.41	5.62	5.70	
		50	4.57	4.66	4.80	4.98	5.21	5.46	5.73	6.00	6.27	6.53	6.62	

### Notes:

1. Q for capacity, P for power. Units in kW
2. All ZF+KQE values are rated at return gas temperature: 20°C and subcooling: 0 K

# Performance data

TF7: 380 V, 3-Phase, 60 Hz ; TFC: 208-230 V, 3-Phase, 60 Hz ; TFD: 460 V, 3-Phase, 60 Hz

## Liquid injection

# R22

Model			Cond. temp. °C	Evap. temp. °C										
				-40	-35	-30	-25	-20	-15	-10	-5	0	5	7
ZF25KQE	TF7 TFC TFD	Q	30	4.97	6.29	7.88	9.76	11.99	14.58	17.57	21.00			
			40	4.57	5.80	7.26	8.99	11.02	13.39	16.14	19.30			
			50	4.15	5.27	6.59	8.16	10.00	12.15	14.64	17.52			
	P	30	4.24	4.30	4.42	4.59	4.81	5.05	5.30	5.56				
		40	4.95	5.02	5.17	5.37	5.62	5.90	6.19	6.49				
		50	5.74	5.84	6.01	6.25	6.53	6.85	7.18	7.52				
ZF28KQE	TF7 TFC TFD	Q	30	5.84	7.39	9.26	11.47	14.08	17.13	20.64	24.67			
			40	5.37	6.81	8.52	10.56	12.95	15.74	18.97	22.67			
			50	4.87	6.19	7.74	9.58	11.75	14.28	17.21	20.58			
	P	30	5.09	5.15	5.30	5.51	5.77	6.06	6.37	6.68				
		40	5.93	6.03	6.20	6.45	6.74	7.08	7.43	7.79				
		50	6.88	7.01	7.22	7.50	7.84	8.21	8.62	9.03				
ZF34KQE	TF7 TFC TFD	Q	30	6.40	8.16	10.27	12.76	15.68	19.06	22.96	27.40			
			40	5.79	7.46	9.43	11.75	14.45	17.58	21.18	25.28			
			50	5.08	6.64	8.47	10.59	13.07	15.92	19.21	22.96			
	P	30	5.21	5.42	5.64	5.86	6.10	6.33	6.58	6.82				
		40	5.96	6.27	6.58	6.88	7.17	7.46	7.73	8.00				
		50	6.83	7.25	7.66	8.04	8.41	8.75	9.07	9.37				
ZF41KQE	TF7 TFC TFD	Q	30	7.65	9.67	12.09	14.95	18.32	22.26	26.82	32.06			
			40	6.99	8.91	11.16	13.81	16.90	20.49	24.65	29.43			
			50	6.13	7.97	10.07	12.51	15.33	18.59	22.36	26.69			
	P	30	6.31	6.62	6.93	7.24	7.55	7.87	8.19	8.51				
		40	7.29	7.69	8.08	8.47	8.85	9.23	9.60	9.96				
		50	8.38	8.87	9.35	9.83	10.28	10.73	11.16	11.57				
ZF49KQE	TF7 TFC TFD	Q	30	9.41	11.83	14.82	18.41	22.63						
			40	8.56	10.84	13.63	16.97	20.88						
			50	7.50	9.64	12.24	15.32	18.93						
	P	30	7.81	8.04	8.36	8.73	9.14							
		40	9.06	9.35	9.74	10.18	10.67							
		50	10.58	10.92	11.36	11.88	12.44							
ZF54KQE	TF7 TFC TFD	Q	30	10.79	13.63	17.01	20.99	25.64						
			40	9.98	12.65	15.79	19.48	23.79						
			50	9.00	11.47	14.35	17.73	21.68						
	P	30	7.93	8.49	9.01	9.56	10.19							
		40	9.46	10.05	10.59	11.16	11.79							
		50	11.51	12.18	12.79	13.41	14.09							

**Notes:**

1. Q for capacity; P for power. Units in kW
2. All ZF+KQE values are rated at return gas temperature: 20°C and subcooling: 0 K

# Performance data

TF7: 380 V, 3-Phase, 60 Hz ; TFC: 208-230 V, 3-Phase, 60 Hz ; TFD: 460 V, 3-Phase, 60 Hz  
Vapor injection

# R22

Model		Cond. temp. °C	Evap. temp. °C										
			-40	-35	-30	-25	-20	-15	-10	-5	0	5	7
ZFI20KQE	Q	30	3.17	3.98	4.96	6.11	7.42	8.88	10.50	12.26	14.16	16.21	17.06
		40	3.16	3.98	4.96	6.08	7.35	8.75	10.30	11.97	13.77	15.70	16.50
		50	2.88	3.72	4.70	5.81	7.05	8.41	9.89	11.49	13.21	15.02	15.78
	P	30	2.47	2.52	2.62	2.76	2.93	3.14	3.36	3.62	3.88	4.16	4.28
		40	2.77	2.91	3.05	3.21	3.36	3.50	3.64	3.77	3.87	3.96	3.99
		50	3.46	3.65	3.81	3.94	4.04	4.10	4.12	4.09	4.00	3.86	3.79
	LO	30	-6.90	-5.80	-4.00	-1.40	1.80	5.30	8.90	12.50	16.00	19.30	20.50
		40	-5.00	-4.00	-2.00	0.90	4.40	8.10	12.00	15.90	19.60	23.10	24.40
		50	3.50	2.00	2.60	4.70	7.80	11.40	15.30	19.20	23.00	26.60	28.00
ZFI23KQE	Q	30	4.22	5.36	6.68	8.22	9.99	12.00	14.30	16.90	19.80	23.10	24.50
		40	4.10	5.22	6.51	7.98	9.67	11.60	13.75	16.20	19.00	22.10	23.40
		50	3.90	5.00	6.25	7.67	9.27	11.10	13.15	15.45	18.05	21.00	22.20
	P	30	2.87	2.97	3.08	3.20	3.33	3.49	3.69	3.93	4.21	4.55	4.70
		40	3.45	3.59	3.73	3.87	4.02	4.18	4.37	4.58	4.83	5.13	5.26
		50	4.15	4.35	4.54	4.71	4.88	5.06	5.25	5.45	5.69	5.95	6.07
	LO	30	-11.40	-13.00	-14.50	-14.40	-12.60	-9.30	-4.80	0.20	5.40	10.40	12.30
		40	-15.60	-13.00	-12.20	-11.20	-9.10	-5.80	-1.60	3.10	8.00	12.70	14.60
		50	-10.60	-4.50	-2.30	-0.90	0.80	3.30	6.60	10.40	14.40	18.30	19.90
ZFI26KQE	Q	30	4.70	5.84	7.28	8.97	10.89	12.99	15.24	17.60	20.04	22.51	23.50
		40	4.63	5.78	7.19	8.85	10.71	12.74	14.89	17.13	19.43	21.75	22.67
		50	4.20	5.36	6.77	8.41	10.23	12.20	14.27	16.42	18.60	20.78	21.64
	P	30	3.51	3.64	3.79	3.98	4.23	4.56	4.99	5.54	6.24	7.10	7.50
		40	3.95	4.20	4.42	4.63	4.85	5.10	5.41	5.79	6.27	6.86	7.14
		50	4.98	5.29	5.52	5.70	5.84	5.96	6.09	6.25	6.45	6.72	6.85
	LO	30	-3.00	-1.60	0.00	2.30	5.30	8.80	12.70	16.90	21.30	25.60	27.40
		40	-0.30	0.90	2.60	5.00	8.10	11.90	16.00	20.40	24.90	29.40	31.20
		50	7.70	6.90	7.30	9.00	11.70	15.30	19.40	23.80	28.40	33.10	34.90
ZFI36KQE	Q	30	6.45	8.00	9.65	11.54	13.82	16.63	20.12	24.42			
		40	6.00	7.53	9.15	10.99	13.21	15.95	19.35	23.56			
		50	5.29	6.78	8.35	10.12	12.26	14.91	18.20	22.28			
	P	30	3.63	3.99	4.40	4.85	5.32	5.79	6.23	6.62			
		40	4.73	5.03	5.39	5.78	6.18	6.57	6.93	7.24			
		50	6.66	6.87	7.12	7.40	7.68	7.94	8.17	8.33			
	LO	30	-10.70	-10.10	-5.90	-1.70	0.80	1.10	-0.80	-4.70			
		40	-0.40	-1.40	1.80	5.30	7.40	7.40	5.30	1.30			
		50	6.70	5.20	8.30	11.80	13.90	13.90	11.70	7.60			
ZFI39KQE	Q	30	7.41	9.17	11.08	13.27	15.89	19.09	23.01	27.81			
		40	6.89	8.64	10.51	12.64	15.20	18.32	22.14	26.82			
		50	6.08	7.78	9.58	11.64	14.10	17.11	20.81	25.35			
	P	30	4.10	4.47	4.93	5.44	5.96	6.47	6.93	7.30			
		40	5.31	5.63	6.03	6.48	6.93	7.35	7.71	7.98			
		50	7.46	7.68	7.97	8.28	8.60	8.88	9.09	9.19			
	LO	30	-17.90	-13.00	-8.60	-5.20	-2.70	-1.30	-0.90	-1.40			
		40	-5.00	-3.20	-0.60	2.00	3.90	5.10	5.30	4.80			
		50	3.60	4.00	6.10	8.60	10.60	11.80	12.10	11.50			

**Notes:**

1. Q for capacity, P for power. Units in kW; LO for liquid out temperature in °C
2. All ZF\*KQE values are rated at return gas temperature: 20°C and max subcooling
3. ■ 20K Superheat



# Performance data

TF7: 380 V, 3-Phase, 60 Hz ; TFC: 208-230 V, 3-Phase, 60 Hz ; TFD: 460 V, 3-Phase, 60 Hz

Vapor injection

# R22

Model			Cond. temp. °C	Evap. temp. °C										
				-40	-35	-30	-25	-20	-15	-10	-5	0	5	7
ZFI50KQE	TF7 TFC TFD	Q	30	9.02	11.02	13.28	15.92	19.08	22.86	27.41	32.84			
			40	8.34	10.35	12.59	15.18	18.25	21.93	26.34	31.61			
			50	7.30	9.29	11.47	13.98	16.94	20.48	24.72	29.80			
	P	30	4.88	5.27	5.82	6.44	7.07	7.64	8.09	8.34				
		40	6.28	6.64	7.12	7.67	8.22	8.69	9.02	9.14				
		50	8.83	9.07	9.42	9.82	10.20	10.50	10.63	10.54				
	LO	30	-12.80	-11.30	-7.40	-3.50	-0.90	-0.10	-0.90	-3.20				
		40	-2.10	-2.40	0.50	3.60	5.70	6.20	5.30	2.80				
		50	5.20	4.40	7.10	10.20	12.30	12.80	11.80	9.30				
ZFI59KQE	TF7 TFC TFD	Q	30	10.78	13.13	15.81	18.96	22.71	27.21	32.59	39.00			
			40	9.96	12.33	14.98	18.07	21.73	26.10	31.31	37.52			
			50	8.70	11.05	13.65	16.64	20.17	24.37	29.39	35.35			
	P	30	5.87	6.45	7.12	7.85	8.61	9.36	10.08	10.73				
		40	7.63	8.13	8.72	9.35	10.00	10.64	11.23	11.73				
		50	10.77	11.11	11.52	11.97	12.43	12.85	13.22	13.49				
	LO	30	-11.50	-8.10	-4.30	-1.10	1.20	2.50	2.80	2.30				
		40	0.30	1.20	3.40	5.80	7.70	8.70	8.90	8.20				
		50	7.60	7.70	9.80	12.20	14.10	15.20	15.50	14.90				
ZFI68KQE	TF7 TFC TFD	Q	30	12.64	15.56	18.75	22.45	26.88						
			40	11.73	14.64	17.78	21.40	25.71						
			50	10.30	13.15	16.20	19.70	23.86						
	P	30	7.03	7.49	8.25	9.16	10.07							
		40	8.97	9.40	10.10	10.91	11.70							
		50	12.57	12.85	13.37	13.98	14.53							
	LO	30	-8.50	-5.20	-1.30	2.10	4.50							
		40	2.80	3.70	6.30	8.90	10.80							
		50	10.50	10.40	12.60	15.20	17.10							
ZFI96KQE	TE7 TEC TED	Q	30	18.35	21.90	26.50	32.10	39.10	47.50	57.50	69.40			
			40	17.95	21.80	26.20	30.90	37.10	44.30	52.80	62.80			
			50			24.50	29.50	35.00	41.20	48.30	56.70			
	P	30	11.60	12.20	12.75	13.40	14.15	15.00	15.95	17.10				
		40	14.60	15.25	15.90	16.45	17.15	17.95	18.80	19.75				
		50			19.75	20.50	21.20	21.80	22.50	23.30				
	LO	30	-14.60	-3.80	3.30	7.50	9.70	10.40	9.90	8.60				
		40	-1.30	1.70	6.70	11.80	16.20	19.60	21.80	23.10				
		50			14.20	18.00	23.20	28.20	32.50	35.80				
ZFI122KQE	TE7 TEC TED	Q	30	23.12	27.63	33.35	40.48	49.23	59.83	72.48	87.40			
			40	22.59	27.44	32.99	38.94	46.69	55.83	66.58	79.16			
			50			30.92	37.15	44.07	51.94	60.87	71.39			
	P	30	14.17	14.86	15.58	16.38	17.27	18.30	19.48	20.86				
		40	17.80	18.63	19.41	20.05	20.93	21.88	22.92	24.09				
		50			24.10	24.98	25.81	26.57	27.50	28.49				
	LO	30	-14.60	-3.80	3.30	7.50	9.70	10.40	9.90	8.60				
		40	-1.30	1.70	6.70	11.80	16.20	19.60	21.80	23.10				
		50			14.20	18.00	23.20	28.20	32.50	35.90				
ZFI140KQE	TE7 TEC TED	Q	30	27.40	32.80	39.50	48.00	58.30	70.80	85.80	103.50			
			40	26.80	32.60	39.10	46.10	55.20	66.00	78.70	93.60			
			50			36.60	44.00	52.10	61.10	71.90	84.40			
	P	30	15.60	16.35	17.15	18.05	19.00	20.10	21.40	23.00				
		40	19.70	20.60	21.40	22.10	23.00	24.10	25.20	26.50				
		50			26.60	27.60	28.50	29.20	30.30	31.40				
	LO	30	-20.90	-9.90	-2.50	2.10	4.50	5.30	4.90	3.50				
		40	-6.90	-3.80	1.40	6.90	11.50	15.10	17.50	18.80				
		50			9.50	13.60	19.00	24.20	28.70	32.10				

**Notes:**

1. Q for capacity, P for power. Units in kW; LO for liquid out temperature in °C
2. All ZF\*KQE values are rated at return gas temperature: 20°C and max subcooling
3.   20K Superheat

# Performance data

TFC: 200 V, 3-Phase, 50 Hz; TFD: 380-420 V, 3-Phase, 50 Hz

## Liquid injection

# R404A

Model			Cond. temp. °C	Evap. temp. °C										
				-40	-35	-30	-25	-20	-15	-10	-5	0	5	7
ZF06KQE	TF5	Q	30	1.28	1.61	2.00	2.47	3.01	3.64	4.38	5.22	6.19	7.28	7.76
			40	1.13	1.43	1.77	2.18	2.65	3.21	3.85	4.58	5.43	6.39	6.81
			50	0.96	1.22	1.51	1.85	2.25	2.71	3.25	3.87	4.59	5.41	5.77
	P	30	1.17	1.23	1.30	1.37	1.45	1.54	1.64	1.75	1.87	2.00	2.05	
		40	1.40	1.46	1.52	1.59	1.67	1.76	1.85	1.96	2.08	2.20	2.26	
		50	1.72	1.77	1.82	1.89	1.96	2.04	2.13	2.24	2.35	2.47	2.52	
ZF08KQE	TF5	Q	30	1.58	1.98	2.46	3.03	3.70	4.48	5.38	6.42	7.61	8.96	9.54
			40	1.39	1.75	2.18	2.68	3.26	3.94	4.73	5.64	6.68	7.86	8.37
			50	1.18	1.50	1.86	2.28	2.77	3.34	4.00	4.76	5.64	6.65	7.10
	P	30	1.39	1.47	1.54	1.63	1.73	1.84	1.95	2.08	2.22	2.37	2.44	
		40	1.67	1.74	1.81	1.89	1.99	2.09	2.21	2.33	2.47	2.62	2.69	
		50	2.05	2.10	2.17	2.25	2.33	2.43	2.54	2.66	2.79	2.94	3.00	
ZF09KQE	TF5	Q	30	1.71	2.17	2.71	3.35	4.10	4.97	5.97	7.13	8.45	9.96	10.61
			40	1.53	1.94	2.41	2.96	3.60	4.35	5.23	6.23	7.39	8.71	9.29
			50	1.32	1.67	2.07	2.52	3.06	3.69	4.42	5.27	6.25	7.38	7.88
	P	30	1.46	1.48	1.52	1.57	1.65	1.74	1.84	1.96	2.09	2.23	2.29	
		40	1.77	1.78	1.81	1.86	1.92	2.00	2.10	2.21	2.33	2.47	2.52	
		50	2.16	2.16	2.18	2.22	2.27	2.34	2.43	2.53	2.65	2.78	2.84	
ZF11KQE	TF5	Q	30	2.17	2.74	3.41	4.19	5.10	6.16	7.41	8.85	10.50	12.39	13.22
			40	1.94	2.45	3.03	3.70	4.49	5.41	6.49	7.75	9.20	10.86	11.60
			50	1.65	2.09	2.58	3.15	3.81	4.58	5.48	6.55	7.78	9.22	9.86
	P	30	1.79	1.82	1.87	1.94	2.03	2.14	2.27	2.41	2.57	2.75	2.83	
		40	2.13	2.15	2.20	2.26	2.34	2.45	2.57	2.70	2.85	3.02	3.09	
		50	2.53	2.56	2.60	2.67	2.75	2.85	2.97	3.10	3.24	3.40	3.47	
ZF13KQE	TFC	Q	30	2.45	3.15	3.98	4.93	6.03	7.30	8.74	10.36	12.19	14.24	15.12
			40	2.19	2.78	3.48	4.31	5.27	6.38	7.66	9.11	10.76	12.61	13.41
			50	1.94	2.40	2.95	3.62	4.42	5.35	6.44	7.70	9.13	10.77	11.48
	P	30	1.87	1.93	2.00	2.08	2.19	2.30	2.44	2.59	2.76	2.95	3.03	
		40	2.27	2.33	2.41	2.49	2.59	2.70	2.83	2.97	3.13	3.30	3.37	
		50	2.78	2.85	2.93	3.02	3.12	3.23	3.35	3.48	3.62	3.78	3.85	
ZF15KQE	TFC	Q	30	3.01	3.89	4.91	6.08	7.44	9.01	10.82	12.89	15.26	17.93	19.10
			40	2.66	3.42	4.29	5.30	6.47	7.84	9.43	11.26	13.36	15.76	16.81
			50	2.36	2.95	3.64	4.44	5.40	6.53	7.86	9.41	11.22	13.31	14.22
	P	30	2.21	2.33	2.45	2.58	2.73	2.90	3.09	3.31	3.56	3.85	3.97	
		40	2.68	2.82	2.95	3.09	3.24	3.41	3.60	3.80	4.04	4.30	4.41	
		50	3.26	3.42	3.58	3.73	3.90	4.07	4.25	4.45	4.67	4.92	5.02	
ZF18KQE	TFC	Q	30	3.70	4.70	5.85	7.20	8.78	10.64	12.81	15.33	18.25	21.58	23.04
			40	3.29	4.17	5.17	6.34	7.70	9.30	11.17	13.36	15.91	18.84	20.13
			50	2.81	3.57	4.41	5.37	6.50	7.83	9.40	11.25	13.42	15.94	17.06
	P	30	2.79	2.89	3.01	3.14	3.29	3.46	3.65	3.85	4.07	4.30	4.40	
		40	3.29	3.40	3.53	3.67	3.83	4.00	4.18	4.38	4.59	4.82	4.91	
		50	3.92	4.04	4.18	4.33	4.49	4.67	4.85	5.05	5.26	5.48	5.57	

### Notes:

1. Q for capacity; P for power. Units in kW
2. All ZF\*KQE values are rated at return gas temperature: 20°C and subcooling: 0 K

# Performance data

TFC: 200 V, 3-Phase, 50 Hz ; TFD: 380-420 V, 3-Phase, 50 Hz

## Liquid injection

# R404A

Model			Cond. temp. °C	Evap. temp. °C										
				-40	-35	-30	-25	-20	-15	-10	-5	0	5	7
ZF25KQE	TFC TFD	Q	30	4.59	5.81	7.32	9.08	11.09	13.32	15.75	18.37			
			40	4.09	5.12	6.42	7.96	9.73	11.71	13.87	16.20			
			50	3.63	4.45	5.50	6.79	8.28	9.96	11.81	13.82			
		P	30	3.03	3.31	3.54	3.76	4.00	4.30	4.67	5.16			
			40	3.43	3.80	4.11	4.39	4.69	5.03	5.44	5.95			
			50	3.84	4.31	4.72	5.09	5.46	5.85	6.32	6.87			
ZF28KQE	TFC TFD	Q	30	5.25	6.65	8.36	10.38	12.67	15.22	18.00	21.00			
			40	4.67	5.85	7.34	9.10	11.12	13.38	15.85	18.51			
			50	4.15	5.08	6.29	7.76	9.46	11.39	13.50	15.79			
		P	30	3.74	4.08	4.37	4.64	4.94	5.30	5.76	6.37			
			40	4.23	4.68	5.07	5.42	5.78	6.20	6.71	7.34			
			50	4.74	5.32	5.82	6.28	6.73	7.22	7.79	8.48			
ZF34KQE	TFC TFD	Q	30	6.03	7.72	9.67	11.94	14.57	17.62	21.16	25.23			
			40	5.30	6.82	8.54	10.51	12.79	15.44	18.51	22.06			
			50	4.47	5.79	7.25	8.90	10.81	13.01	15.59	18.58			
		P	30	4.18	4.41	4.67	4.93	5.22	5.53	5.85	6.20			
			40	4.85	5.16	5.46	5.77	6.08	6.40	6.73	7.07			
			50	5.66	6.04	6.41	6.77	7.13	7.48	7.82	8.16			
ZF41KQE	TFC TFD	Q	30	7.57	9.62	11.96	14.69	17.88	21.62	25.98	31.04			
			40	6.71	8.56	10.62	12.98	15.71	18.90	22.64	26.99			
			50	5.65	7.29	9.06	11.04	13.31	15.96	19.05	22.68			
		P	30	5.07	5.40	5.75	6.11	6.48	6.88	7.30	7.75			
			40	5.95	6.33	6.72	7.12	7.52	7.94	8.36	8.81			
			50	6.95	7.40	7.85	8.29	8.74	9.18	9.63	10.09			
ZF49KQE	TFC TFD	Q	30	9.14	11.54	14.39	17.75	21.67						
			40	8.07	10.21	12.72	15.65	19.05						
			50	6.80	8.66	10.80	13.27	16.14						
		P	30	6.24	6.53	6.90	7.33	7.81						
			40	7.36	7.67	8.06	8.52	9.02						
			50	8.73	9.07	9.48	9.97	10.51						
ZF54KQE	TFC TFD	Q	30	10.46	13.21	16.47	20.31	24.80						
			40	9.23	11.69	14.56	17.91	21.80						
			50	7.78	9.91	12.36	15.19	18.47						
		P	30	7.14	7.47	7.90	8.39	8.94						
			40	8.42	8.77	9.22	9.75	10.33						
			50	9.99	10.37	10.85	11.41	12.03						

**Notes:**

1. Q for capacity; P for power. Units in kW
2. All ZF\*KQE values are rated at return gas temperature: 20°C and subcooling: 0 K

# Performance data

TFC: 200 V, 3-Phase, 50 Hz ; TFD: 380-420 V, 3-Phase, 50 Hz

Vapor injection

# R404A

Model		Cond. temp. °C	Evap. temp. °C											
			-40	-35	-30	-25	-20	-15	-10	-5	0	5	7	
ZFI20KQE	TFC	Q	30	3.43	4.28	5.23	6.30	7.50	8.86	10.40	12.14	14.09	16.28	17.23
			40	3.25	4.07	4.99	6.04	7.23	8.60	10.14	11.90	13.88	16.11	17.08
			50	2.92	3.70	4.59	5.62	6.80	8.17	9.73	11.50	13.51	15.76	16.74
	TFD	P	30	2.17	2.23	2.30	2.38	2.46	2.53	2.58	2.62	2.62	2.59	2.57
			40	2.73	2.78	2.84	2.92	3.01	3.09	3.16	3.22	3.25	3.27	3.26
			50	3.56	3.58	3.62	3.68	3.75	3.82	3.90	3.96	4.01	4.04	4.05
	LO	30	-13.50	-9.80	-6.10	-2.00	2.30	6.50	10.50	14.20	17.40	20.00	20.90	
		40	-6.70	-4.80	-2.20	1.00	4.60	8.30	12.00	15.40	18.20	20.60	21.40	
		50	6.00	4.80	5.10	6.50	8.90	11.60	14.50	17.20	19.70	21.80	22.50	
ZFI23KQE	TFC	Q	30	4.85	5.51	6.46	7.67	9.13	10.80	12.75	14.85	17.15	19.65	20.70
			40	4.78	5.36	6.23	7.35	8.73	10.35	12.20	14.25	16.45	18.90	19.90
			50	4.78	5.26	6.01	7.04	8.31	9.82	11.55	13.50	15.65	18.00	18.95
	TFD	P	30	2.68	2.82	2.96	3.09	3.21	3.32	3.44	3.55	3.66	3.76	3.80
			40	3.19	3.38	3.55	3.72	3.87	4.02	4.15	4.28	4.40	4.51	4.55
			50	3.90	4.13	4.35	4.55	4.73	4.90	5.05	5.19	5.32	5.43	5.48
	LO	30	-33.40	-15.50	-6.10	-0.50	3.60	7.10	10.60	13.90	17.30	20.40	21.60	
		40	-28.70	-12.10	-3.00	2.70	6.80	10.40	13.80	17.20	20.40	23.50	24.70	
		50	-25.90	-9.70	-0.40	5.60	10.00	13.80	17.40	20.80	24.10	27.10	28.20	
ZFI26KQE	TFC	Q	30	5.14	6.29	7.61	9.14	10.90	12.91	15.20	17.79	20.72	24.02	25.44
			40	5.09	6.12	7.33	8.74	10.39	12.30	14.49	17.01	19.86	23.06	24.45
			50	5.08	5.97	7.03	8.32	9.84	11.62	13.70	16.10	18.83	21.94	23.30
	TFD	P	30	3.22	3.38	3.54	3.70	3.84	3.98	4.11	4.24	4.37	4.50	4.55
			40	3.85	4.07	4.28	4.47	4.65	4.81	4.97	5.12	5.26	5.39	5.44
			50	4.74	5.01	5.26	5.50	5.70	5.90	6.07	6.24	6.38	6.52	6.57
	LO	30	-13.00	-8.10	-4.00	-0.10	3.70	7.20	10.50	13.60	16.10	18.10	18.80	
		40	-10.10	-5.20	-0.80	3.30	7.30	10.90	14.20	17.10	19.50	21.50	22.10	
		50	-7.30	-2.10	2.60	7.00	11.10	14.90	18.20	21.00	23.40	25.10	25.70	
ZFI36KQE	TFC	Q	30	6.48	8.01	9.76	11.70	13.85	16.20	18.73	21.45			
			40	6.29	7.67	9.27	11.08	13.09	15.32	17.74	20.32			
			50	6.24	7.42	8.82	10.43	12.26	14.30	16.54	18.97			
	TFD	P	30	3.78	4.05	4.29	4.52	4.75	4.97	5.19	5.42			
			40	4.46	4.86	5.21	5.52	5.80	6.05	6.27	6.47			
			50	5.21	5.78	6.29	6.72	7.09	7.42	7.69	7.91			
	LO	30	-13.80	-10.00	-5.40	-0.70	3.90	8.10	12.00	15.40				
		40	-10.80	-5.80	-0.50	4.50	9.10	13.20	16.90	20.20				
		50	-11.10	-3.70	3.00	9.00	14.20	18.50	22.30	25.40				
ZFI39KQE	TFC	Q	30	7.44	9.19	11.19	13.43	15.89	18.58	21.49	24.61			
			40	7.22	8.80	10.63	12.71	15.04	17.58	20.35	23.34			
			50	7.16	8.51	10.12	11.97	14.06	16.41	18.97	21.76			
	TFD	P	30	4.49	4.81	5.10	5.38	5.64	5.91	6.17	6.45			
			40	5.30	5.78	6.19	6.56	6.90	7.19	7.46	7.70			
			50	6.19	6.87	7.47	7.99	8.43	8.82	9.14	9.40			
	LO	30	-13.80	-10.00	-5.40	-0.70	3.90	8.10	12.00	15.40				
		40	-10.80	-5.80	-0.50	4.50	9.00	13.20	16.90	20.10				
		50	-11.10	-3.70	3.00	9.00	14.20	18.50	22.30	25.40				
ZFI50KQE	TFC	Q	30	9.11	10.80	12.99	15.63	18.68	22.06	25.71	29.59			
			40	8.66	10.29	12.40	14.91	17.77	20.94	24.34	27.91			
			50	8.04	9.65	11.68	14.07	16.79	19.75	22.91	26.23			
	TFD	P	30	5.04	5.42	5.76	6.08	6.38	6.67	6.98	7.31			
			40	6.06	6.49	6.89	7.26	7.61	7.97	8.33	8.72			
			50	7.31	7.79	8.25	8.67	9.09	9.50	9.92	10.38			
	LO	30	-18.10	-7.60	-2.60	0.50	3.40	6.70	10.50	14.80				
		40	-12.10	-2.70	1.90	5.00	8.10	11.70	15.70	20.20				
		50	-3.60	3.70	7.30	10.10	13.10	16.70	20.80	25.20				

**Notes:**

1. Q for capacity, P for power. Units in kW; LO for liquid out temperature in °C
2. All ZF+KQE values are rated at return gas temperature: 20°C and max subcooling
3.   20K Superheat

# Performance data

TFC: 200 V, 3-Phase, 50 Hz; TFD: 380-420 V, 3-Phase, 50 Hz

Vapor injection

# R404A

Model			Cond. temp. °C	Evap. temp. °C										
				-40	-35	-30	-25	-20	-15	-10	-5	0	5	7
ZFI59KQE	TFC	Q	30	11.10	13.15	15.82	19.05	22.74	26.86	31.31	36.02			
			40	10.55	12.53	15.09	18.16	21.65	25.51	29.65	34.01			
			50	9.80	11.75	14.21	17.14	20.45	24.05	27.92	31.93			
	TFD	P	30	6.15	6.61	7.03	7.41	7.77	8.14	8.51	8.92			
			40	7.39	7.91	8.39	8.85	9.29	9.72	10.17	10.65			
			50	8.92	9.51	10.05	10.58	11.09	11.58	12.11	12.66			
	LO	30	-15.40	-5.10	-0.30	2.70	5.60	8.80	12.60	16.70				
		40	-9.50	-0.30	4.20	7.20	10.20	13.60	17.50	21.80				
		50	-1.20	5.90	9.50	12.10	15.00	18.60	22.50	26.90				
ZFI68KQE	TFC	Q	30	12.60	14.92	17.95	21.61	25.81						
			40	11.97	14.23	17.13	20.60	24.56						
			50	11.12	13.33	16.14	19.45	23.20						
	TFD	P	30	7.15	7.68	8.17	8.62	9.04						
			40	8.60	9.20	9.77	10.29	10.80						
			50	10.36	11.05	11.70	12.30	12.89						
	LO	30	-15.40	-5.10	-0.30	2.70	5.50							
		40	-9.60	-0.40	4.10	7.20	10.20							
		50	-1.20	5.90	9.40	12.10	15.00							
ZFI81KQE	TFC	Q	30	14.37	17.01	20.46	24.63	29.43						
			40	13.66	16.23	19.55	23.50	28.03						
			50	12.68	15.21	18.41	22.18	26.47						
	TFD	P	30	8.26	8.87	9.44	9.96	10.45						
			40	9.94	10.64	11.30	11.90	12.49						
			50	11.98	12.78	13.53	14.23	14.91						
	LO	30	-10.00	-0.20	4.40	7.30	9.90							
		40	-4.50	4.20	8.50	11.40	14.20							
		50	3.50	10.20	13.60	16.10	18.80							
ZFI96KQE	TEC	Q	30	18.35	22.00	26.50	32.20	39.10	47.50	57.60	69.40			
			40	17.45	21.30	25.70	30.90	37.10	44.40	52.90	62.90			
			50	14.30	18.70	24.20	29.20	34.80	41.10	48.40	56.80			
	TED	P	30	10.75	11.30	11.85	12.45	13.10	13.90	14.80	15.85			
			40	13.30	13.95	14.60	15.25	15.90	16.60	17.40	18.30			
			50	16.85	17.80	18.10	18.80	19.50	20.20	20.90	21.60			
	LO	30	-10.40	-2.80	2.10	5.00	6.40	6.60	5.90	4.60				
		40	-0.90	1.10	4.60	8.10	11.00	13.20	14.60	15.20				
		50	16.20	10.20	10.00	12.50	16.10	19.50	22.40	24.40				
ZFI122KQE	TEC	Q	30	23.14	27.67	33.39	40.53	49.30	59.91	72.57	87.50			
			40	21.96	26.81	32.42	38.99	46.75	55.91	66.68	79.27			
			50	18.04	23.62	30.52	36.81	43.84	51.83	60.98	71.51			
	TED	P	30	13.14	13.77	14.45	15.18	16.01	16.96	18.06	19.33			
			40	16.21	17.02	17.80	18.59	19.40	20.28	21.24	22.32			
			50	20.57	21.72	22.09	22.95	23.78	24.62	25.48	26.39			
	LO	30	-10.40	-2.80	2.10	5.00	6.40	6.60	5.90	4.60				
		40	-0.90	1.10	4.60	8.10	11.00	13.20	14.60	15.20				
		50	16.20	10.20	10.00	12.50	16.10	19.50	22.40	24.40				
ZFI140KQE	TEC	Q	30	25.70	30.70	37.00	44.90	54.60	66.50	80.60	97.20			
			40	24.30	29.50	35.70	43.00	51.60	61.90	73.90	87.90			
			50	19.80	27.20	33.60	40.50	48.30	57.30	67.50	79.20			
	TED	P	30	14.30	15.05	15.80	16.60	17.50	18.50	19.65	21.00			
			40	17.70	18.60	19.50	20.30	21.20	22.10	23.10	24.30			
			50	22.40	23.10	24.10	25.10	25.90	26.80	27.80	28.80			
	LO	30	-8.00	0.00	4.90	7.60	8.80	8.90	8.10	6.80				
		40	2.20	4.60	7.90	11.10	13.80	15.70	16.80	17.30				
		50	18.80	13.50	13.30	15.60	18.80	21.90	24.50	26.40				

**Notes:**

1. Q for capacity, P for power. Units in kW; LO for liquid out temperature in °C
2. All ZF\*KQE values are rated at return gas temperature: 20°C and max subcooling
3.  20K Superheat

# Performance data

**TF7:** 380 V, 3-Phase, 60 Hz; **TFC:** 208-230 V, 3-Phase, 60 Hz; **TFD:** 460 V, 3-Phase, 60 Hz  
**Liquid injection**

# R404A

Model			Cond. temp. °C	Evap. temp. °C										
				-40	-35	-30	-25	-20	-15	-10	-5	0	5	7
ZF06KQE	TF5 TFD	Q	30	1.49	1.90	2.36	2.90	3.53	4.26	5.12	6.12	7.27	8.59	9.17
			40	1.30	1.67	2.09	2.56	3.10	3.74	4.48	5.34	6.34	7.49	7.99
			50	1.11	1.45	1.80	2.20	2.65	3.17	3.78	4.49	5.32	6.29	6.72
		P	30	1.27	1.29	1.34	1.43	1.52	1.63	1.74	1.84	1.93	1.99	2.00
			40	1.57	1.57	1.60	1.67	1.77	1.88	2.00	2.12	2.22	2.32	2.34
			50	1.94	1.90	1.92	1.97	2.06	2.17	2.30	2.43	2.56	2.68	2.72
ZF08KQE	TF5 TFD	Q	30	1.90	2.39	2.98	3.66	4.47	5.42	6.51	7.76	9.20	10.83	11.53
			40	1.68	2.12	2.64	3.24	3.95	4.77	5.72	6.81	8.07	9.50	10.12
			50	1.42	1.81	2.25	2.76	3.35	4.03	4.83	5.76	6.82	8.04	8.58
		P	30	1.57	1.63	1.71	1.80	1.92	2.04	2.17	2.32	2.46	2.61	2.66
			40	1.91	1.95	2.01	2.09	2.20	2.32	2.45	2.60	2.75	2.91	2.98
			50	2.40	2.40	2.44	2.50	2.59	2.69	2.82	2.96	3.11	3.27	3.34
ZF09KQE	TF5 TFD	Q	30	2.11	2.67	3.32	4.08	4.98	6.02	7.23	8.62	10.23	12.05	12.85
			40	1.87	2.37	2.94	3.60	4.37	5.27	6.32	7.53	8.93	10.54	11.24
			50	1.60	2.03	2.51	3.06	3.71	4.46	5.34	6.36	7.56	8.94	9.55
		P	30	1.58	1.63	1.69	1.78	1.88	2.01	2.15	2.31	2.49	2.68	2.76
			40	1.92	1.95	2.01	2.09	2.18	2.30	2.44	2.59	2.76	2.95	3.03
			50	2.34	2.37	2.41	2.48	2.56	2.67	2.80	2.95	3.12	3.30	3.38
ZF11KQE	TF5 TFD	Q	30	2.60	3.30	4.11	5.07	6.19	7.49	8.99	10.72	12.68	14.90	15.87
			40	2.33	2.94	3.65	4.48	5.46	6.59	7.90	9.41	11.13	13.10	13.95
			50	1.99	2.52	3.11	3.81	4.62	5.57	6.68	7.96	9.44	11.14	11.88
		P	30	1.90	1.97	2.06	2.18	2.33	2.50	2.70	2.92	3.17	3.45	3.57
			40	2.30	2.37	2.46	2.57	2.71	2.86	3.05	3.25	3.48	3.74	3.85
			50	2.79	2.86	2.95	3.06	3.19	3.35	3.52	3.71	3.93	4.17	4.27
ZF13KQE	TF7 TFC TFD	Q	30	2.95	3.80	4.79	5.93	7.24	8.73	10.40	12.29	14.40	16.74	17.74
			40	2.60	3.32	4.16	5.15	6.31	7.63	9.14	10.85	12.77	14.92	15.85
			50	2.28	2.83	3.50	4.31	5.27	6.39	7.70	9.20	10.91	12.84	13.68
		P	30	2.24	2.30	2.39	2.50	2.65	2.82	3.03	3.28	3.56	3.89	4.03
			40	2.70	2.76	2.85	2.95	3.09	3.25	3.44	3.67	3.92	4.22	4.35
			50	3.30	3.37	3.45	3.55	3.68	3.83	4.01	4.21	4.45	4.71	4.83
ZF15KQE	TF7 TFC TFD	Q	30	3.74	4.72	5.88	7.25	8.86	10.73	12.90	15.40	18.26	21.50	22.91
			40	3.30	4.16	5.17	6.35	7.74	9.36	11.24	13.41	15.91	18.76	20.00
			50	2.81	3.54	4.38	5.36	6.51	7.85	9.43	11.27	13.39	15.83	16.90
		P	30	2.70	2.79	2.92	3.07	3.26	3.49	3.78	4.13	4.54	5.02	5.24
			40	3.19	3.34	3.49	3.66	3.85	4.07	4.32	4.62	4.96	5.36	5.54
			50	3.77	3.98	4.19	4.40	4.62	4.84	5.08	5.36	5.66	6.01	6.16
ZF18KQE	TF7 TFC TFD	Q	30	4.46	5.67	7.07	8.70	10.61	12.84	15.43	18.42	21.87	25.81	27.53
			40	3.98	5.05	6.26	7.66	9.29	11.21	13.44	16.04	19.05	22.51	24.03
			50	3.47	4.37	5.37	6.53	7.87	9.46	11.32	13.51	16.06	19.03	20.34
		P	30	3.27	3.37	3.52	3.72	3.96	4.24	4.55	4.88	5.23	5.59	5.73
			40	3.88	3.98	4.13	4.34	4.59	4.87	5.19	5.53	5.88	6.24	6.39
			50	4.57	4.68	4.85	5.07	5.33	5.63	5.96	6.31	6.68	7.05	7.20

**Notes:**

1. Q for capacity; P for power. Units in kW
2. All ZF+KQE values are rated at return gas temperature: 20°C and subcooling: 0 K

# Performance data

TF7: 380 V, 3-Phase, 60 Hz; TFC: 208-230 V, 3-Phase, 60 Hz; TFD: 460 V, 3-Phase, 60 Hz

## Liquid injection

# R404A

Model			Cond. temp. °C	Evap. temp. °C										
				-40	-35	-30	-25	-20	-15	-10	-5	0	5	7
ZF25KQE	Q	TF7 TFC TFD	30	5.52	7.01	8.78	10.86	13.27	16.05	19.21	22.79			
			40	4.93	6.19	7.72	9.53	11.67	14.15	17.01	20.27			
			50	4.44	5.42	6.65	8.15	9.96	12.10	14.60	17.48			
	P	30	3.63	3.96	4.28	4.60	4.90	5.21	5.53	5.87				
		40	4.06	4.50	4.91	5.30	5.68	6.04	6.41	6.78				
		50	4.46	5.03	5.56	6.06	6.52	6.97	7.40	7.82				
ZF28KQE	Q	TF7 TFC TFD	30	6.31	8.01	10.03	12.41	15.16	18.33	21.94	26.03			
			40	5.63	7.07	8.82	10.89	13.33	16.17	19.43	23.15			
			50	5.07	6.19	7.59	9.31	11.38	13.82	16.67	19.97			
	P	30	4.47	4.89	5.29	5.67	6.05	6.43	6.83	7.25				
		40	5.00	5.55	6.06	6.54	7.00	7.45	7.90	8.36				
		50	5.50	6.21	6.86	7.47	8.05	8.59	9.12	9.64				
ZF34KQE	Q	TF7 TFC TFD	30	7.22	9.25	11.58	14.29	17.44	21.10	25.33	30.21			
			40	6.34	8.16	10.22	12.59	15.32	18.49	22.16	26.41			
			50	5.35	6.93	8.68	10.66	12.94	15.58	18.66	22.24			
	P	30	5.08	5.37	5.68	6.01	6.36	6.73	7.13	7.55				
		40	5.91	6.28	6.65	7.02	7.40	7.79	8.19	8.60				
		50	6.89	7.35	7.80	8.25	8.68	9.10	9.52	9.93				
ZF41KQE	Q	TF7 TFC TFD	30	9.12	11.59	14.41	17.70	21.55	26.05	31.30	37.40			
			40	8.09	10.31	12.80	15.64	18.93	22.78	27.27	32.51			
			50	6.81	8.79	10.92	13.30	16.04	19.22	22.96	27.33			
	P	30	6.11	6.51	6.92	7.36	7.81	8.29	8.80	9.34				
		40	7.17	7.63	8.10	8.57	9.06	9.56	10.08	10.61				
		50	8.37	8.92	9.45	9.99	10.52	11.06	11.60	12.15				
ZF49KQE	Q	TF7 TFC TFD	30	11.01	13.90	17.34	21.38	26.11						
			40	9.72	12.31	15.33	18.85	22.95						
			50	8.19	10.44	13.01	15.99	19.44						
	P	30	7.52	7.87	8.31	8.83	9.41							
		40	8.86	9.24	9.71	10.26	10.87							
		50	10.52	10.92	11.43	12.01	12.67							
ZF54KQE	Q	TF7 TFC TFD	30	12.55	15.85	19.76	24.38	29.76						
			40	11.08	14.03	17.47	21.49	26.17						
			50	9.33	11.90	14.83	18.23	22.16						
	P	30	8.57	8.97	9.48	10.07	10.73							
		40	10.10	10.53	11.07	11.70	12.39							
		50	11.99	12.45	13.02	13.69	14.44							

**Notes:**

1. Q for capacity; P for power. Units in kW
2. All ZF+KQE values are rated at return gas temperature: 20°C and subcooling: 0 K

# Performance data

**TF7:** 380 V, 3-Phase, 60 Hz ; **TFC:** 208-230 V, 3-Phase, 60 Hz ; **TFD:** 460 V, 3-Phase, 60 Hz  
**Vapor injection**

# R404A

Model		Cond. temp. °C	Evap. temp. °C											
			-40	-35	-30	-25	-20	-15	-10	-5	0	5	7	
ZFI20KQE	TF7 TFC TFD	Q	30	4.27	5.27	6.40	7.69	9.15	10.81	12.68	14.80	17.16	19.82	20.96
			40	4.21	5.16	6.25	7.48	8.89	10.50	12.32	14.38	16.71	19.30	20.43
			50	4.01	4.91	5.95	7.13	8.49	10.05	11.82	13.84	16.11	18.67	19.78
	P	30	2.65	2.79	2.93	3.05	3.16	3.26	3.35	3.43	3.49	3.55	3.57	
		40	3.24	3.41	3.57	3.72	3.86	3.99	4.10	4.21	4.31	4.39	4.42	
		50	4.00	4.19	4.38	4.55	4.71	4.87	5.01	5.15	5.28	5.40	5.45	
	LO	30	-9.30	-6.50	-3.30	0.20	3.90	7.70	11.30	14.50	17.50	19.80	20.60	
		40	-9.40	-6.00	-2.40	1.60	5.70	9.80	13.50	16.90	19.80	22.20	22.90	
		50	-7.10	-3.50	0.40	4.70	8.90	13.00	16.80	20.10	22.90	25.10	25.80	
ZFI23KQE	TF7 TFC TFD	Q	30	5.77	6.56	7.69	9.13	10.85	12.90	15.15	17.70	20.40	23.40	24.60
			40	5.69	6.38	7.41	8.75	10.40	12.30	14.50	16.95	19.60	22.50	23.70
			50	5.69	6.26	7.16	8.37	9.89	11.70	13.75	16.10	18.65	21.40	22.60
	P	30	3.16	3.33	3.49	3.64	3.78	3.92	4.06	4.19	4.31	4.44	4.49	
		40	3.76	3.98	4.19	4.39	4.57	4.74	4.90	5.05	5.19	5.32	5.37	
		50	4.60	4.88	5.13	5.37	5.58	5.78	5.96	6.13	6.28	6.41	6.46	
	LO	30	-31.80	-14.00	-4.70	0.80	4.70	8.20	11.50	14.90	18.20	21.40	22.60	
		40	-27.20	-10.70	-1.70	3.80	7.80	11.30	14.70	18.10	21.40	24.50	25.70	
		50	-24.10	-8.10	1.00	6.70	11.00	14.80	18.30	21.70	25.00	28.00	29.20	
ZFI26KQE	TF7 TFC TFD	Q	30	6.30	7.81	9.47	11.34	13.43	15.81	18.50	21.55	24.98	28.86	30.55
			40	6.03	7.47	9.04	10.79	12.76	14.98	17.49	20.35	23.58	27.23	28.81
			50	5.64	6.99	8.46	10.08	11.89	13.94	16.27	18.91	21.90	25.29	26.77
	P	30	3.80	4.05	4.30	4.55	4.80	5.07	5.34	5.64	5.97	6.33	6.49	
		40	4.50	4.83	5.15	5.46	5.75	6.04	6.34	6.64	6.95	7.29	7.43	
		50	5.46	5.89	6.28	6.64	6.98	7.30	7.61	7.92	8.22	8.54	8.67	
	LO	30	-12.20	-8.00	-4.10	-0.10	3.90	7.80	11.30	14.40	17.20	19.20	19.90	
		40	-9.60	-4.70	-0.20	4.30	8.60	12.60	16.20	19.30	21.90	23.90	24.50	
		50	-5.80	-0.30	4.80	9.60	14.10	18.20	21.80	24.90	27.40	29.20	29.80	
ZFI36KQE	TF7 TFC TFD	Q	30	7.73	9.58	11.62	13.92	16.56	19.64	23.23	27.39			
			40	7.53	9.15	10.97	13.08	15.56	18.50	21.95	26.01			
			50	7.74	9.00	10.49	12.29	14.48	17.14	20.35	24.21			
	P	30	4.46	4.84	5.16	5.45	5.73	6.03	6.38	6.79				
		40	5.25	5.74	6.17	6.56	6.95	7.36	7.80	8.31				
		50	6.26	6.85	7.37	7.88	8.38	8.89	9.44	10.08				
	LO	30	-12.60	-9.00	-4.10	0.60	4.70	7.70	9.80	11.00				
		40	-9.90	-3.90	2.10	7.10	10.80	13.40	14.90	15.50				
		50	-16.10	-3.90	5.40	12.10	16.70	19.50	20.90	21.00				
ZFI39KQE	TF7 TFC TFD	Q	30	8.89	11.02	13.36	16.01	19.06	22.59	26.72	31.51			
			40	8.66	10.53	12.62	15.05	17.90	21.28	25.25	29.93			
			50	8.91	10.35	12.06	14.14	16.65	19.72	23.41	27.86			
	P	30	5.35	5.80	6.18	6.53	6.87	7.23	7.65	8.14				
		40	6.29	6.88	7.39	7.87	8.33	8.82	9.35	9.96				
		50	7.51	8.21	8.84	9.45	10.04	10.66	11.32	12.08				
	LO	30	-12.60	-9.00	-4.10	0.60	4.70	7.70	9.80	11.00				
		40	-9.90	-3.90	2.10	7.10	10.80	13.40	14.90	15.50				
		50	-16.10	-3.90	5.40	12.10	16.70	19.50	20.90	21.00				
ZFI50KQE	TF7 TFC TFD	Q	30	10.79	12.78	15.38	18.52	22.10	26.11	30.43	35.02			
			40	10.25	12.19	14.67	17.65	21.05	24.80	28.83	33.06			
			50	9.53	11.42	13.82	16.66	19.88	23.40	27.14	31.04			
	P	30	5.95	6.40	6.80	7.18	7.53	7.88	8.24	8.63				
		40	7.15	7.66	8.13	8.57	8.99	9.41	9.84	10.31				
		50	8.63	9.20	9.73	10.25	10.74	11.23	11.72	12.25				
	LO	30	-15.40	-5.10	-0.30	2.70	5.60	8.80	12.60	16.70				
		40	-9.50	-0.40	4.20	7.20	10.20	13.60	17.50	21.80				
		50	-1.20	5.90	9.50	12.10	15.00	18.50	22.50	26.90				

**Notes:**

1. Q for capacity, P for power. Units in kW; LO for liquid out temperature in °C
2. All ZF+KQE values are rated at return gas temperature: 20°C and max subcooling
3.   20K Superheat



# Performance data

**TF7:** 380 V, 3-Phase, 60 Hz; **TFC:** 208-230 V, 3-Phase, 60 Hz; **TFD:** 460 V, 3-Phase, 60 Hz  
**Vapor injection**

# R404A

Model			Cond. temp. °C	Evap. temp. °C										
				-40	-35	-30	-25	-20	-15	-10	-5	0	5	7
ZF159KQE	TF7	Q	30	13.38	15.84	19.06	22.95	27.40	32.36	37.72	43.40			
			40	12.71	15.10	18.18	21.88	26.09	30.74	35.73	40.97			
			50	11.81	14.16	17.12	20.65	24.64	28.97	33.64	38.46			
	TFC	P	30	7.41	7.96	8.46	8.93	9.37	9.80	10.25	10.74			
			40	8.90	9.53	10.11	10.66	11.19	11.71	12.25	12.83			
			50	10.74	11.45	12.11	12.75	13.36	13.95	14.59	15.25			
	TFD	LO	30	-15.40	-5.10	-0.30	2.70	5.60	8.80	12.60	16.70			
			40	-9.50	-0.30	4.20	7.20	10.20	13.60	17.50	21.80			
			50	-1.20	5.90	9.50	12.10	15.00	18.60	22.50	26.90			
ZF168KQE	TF7	Q	30	15.12	17.91	21.54	25.94	30.99						
			40	14.37	17.08	20.57	24.73	29.49						
			50	13.35	16.00	19.37	23.35	27.85						
	TFC	P	30	8.58	9.22	9.80	10.34	10.86						
			40	10.32	11.05	11.73	12.35	12.96						
			50	12.44	13.27	14.05	14.77	15.48						
	TFD	LO	30	-15.40	-5.10	-0.30	2.70	5.50						
			40	-9.60	-0.40	4.10	7.20	10.20						
			50	-1.20	5.90	9.40	12.10	15.00						
ZF181KQE	TF7	Q	30	17.37	20.58	24.75	29.80	35.61						
			40	16.52	19.63	23.63	28.41	33.88						
			50	15.33	18.39	22.26	26.82	32.00						
	TFC	P	30	10.23	10.99	11.69	12.33	12.94						
			40	12.30	13.17	13.98	14.73	15.45						
			50	14.83	15.82	16.74	17.61	18.45						
	TFD	LO	30	-15.40	-5.10	-0.30	2.70	5.50						
			40	-9.60	-0.40	4.10	7.20	10.20						
			50	-1.20	5.90	9.40	12.10	15.00						
ZF196KQE	TF7	Q	30	21.40	25.60	30.90	37.50	45.70	55.50	67.20	81.10			
			40	20.30	24.80	30.00	36.10	43.30	51.80	61.80	73.40			
			50	16.60	21.70	28.30	34.10	40.60	48.00	56.50	66.30			
	TFC	P	30	13.00	13.65	14.30	15.05	15.85	16.80	17.90	19.15			
			40	16.05	16.85	17.65	18.40	19.20	20.10	21.00	22.10			
			50	20.30	21.40	21.90	22.70	23.60	24.40	25.20	26.10			
	TFD	LO	30	-6.40	0.90	5.70	8.40	9.70	9.90	9.30	8.00			
			40	2.80	4.70	8.00	11.40	14.20	16.30	17.60	18.20			
			50	19.30	13.50	13.20	15.70	19.10	22.30	25.10	27.10			
ZF1122KQE	TE7	Q	30	27.01	32.29	38.98	47.31	57.54	69.93	84.71	102.13			
			40	25.63	31.29	37.84	45.51	54.57	65.26	77.84	92.54			
			50	20.92	27.41	35.62	42.97	51.17	60.50	71.18	83.48			
	TEC	P	30	15.86	16.63	17.45	18.34	19.34	20.48	21.81	23.35			
			40	19.58	20.55	21.49	22.44	23.43	24.49	25.65	26.96			
			50	24.75	26.13	26.66	27.71	28.72	29.72	30.76	31.87			
	TED	LO	30	-6.40	0.90	5.70	8.40	9.70	9.90	9.30	8.00			
			40	2.80	4.70	8.00	11.40	14.20	16.30	17.60	18.20			
			50	19.30	13.50	13.20	15.70	19.10	22.30	25.10	27.00			
ZF1140KQE	TE7	Q	30	31.00	36.90	44.50	54.00	65.80	80.00	97.00	117.00			
			40	29.20	35.50	43.00	51.80	62.20	74.50	88.90	106.00			
			50	23.90	32.80	40.40	48.80	58.20	68.90	81.20	95.40			
	TEC	P	30	17.15	18.10	19.00	19.95	21.00	22.20	23.60	25.20			
			40	21.20	22.30	23.40	24.40	25.40	26.50	27.80	29.20			
			50	26.90	27.70	29.00	30.10	31.10	32.20	33.30	34.50			
	TED	LO	30	-8.50	-0.50	4.40	7.20	8.40	8.40	7.70	6.40			
			40	1.80	4.20	7.50	10.70	13.40	15.30	16.50	16.90			
			50	18.40	13.10	12.90	15.20	18.40	21.60	24.20	26.10			

**Notes:**

1. Q for capacity, P for power. Units in kW; LO for liquid out temperature in °C
2. All ZF+KQE values are rated at return gas temperature: 20°C and max subcooling
3.   20K Superheat

# Technical data

Compressor model				Liquid injection												
				ZF06KQE	ZF08KQE	ZF09KQE	ZF11KQE	ZF13KQE	ZF15KQE	ZF18KQE	ZF25KQE	ZF28KQE	ZF34KQE	ZF41KQE	ZF49KQE	ZF54KQE
Nominal horsepower		hp		2	2.5	3	3.5	4	5	6	7.5	9	10	13	15	17
Displacement	50 Hz	m³/hr		5.9	7.3	8.0	10.0	11.7	14.4	17.1	21.4	25.1	29.1	35.3	42.4	48.3
	60 Hz			7.1	8.8	9.7	12.1	14.1	17.4	20.6	25.8	30.3	35.1	42.6	51.2	58.3
Motor type	50 Hz			TFD	TFD	TFD	TFD	TFD	TFD	TFD	TFD	TFD	TFD	TFD	TFD	TFD
				TF5	TF5	TF5	TF5	TFC	TFC	TFC	TFC	TFC	TFC	TFC	TFC	TFC
	60 Hz			TFD	TFD	TFD	TFD	TFD	TFD	TFD	TFD	TFD	TFD	TFD	TFD	TFD
				TF5	TF5	TF5	TF5	TFC	TFC	TFC	TFC	TFC	TFC	TFC	TFC	TFC
			NA	NA	NA	NA	TF7	TF7	TF7	TF7	TF7	TF7	TF7	TF7	TF7	TF7
Locked rotor current (LRA)	50 Hz	Amps	TFD	26.0	32.0	40.0	46.0	51.5	64.0	74.0	102.0	121.4	100.0	118.0	139.0	168.0
			TFC/5	56.0	70.0	83.0	87.0	94.0	122.0	171.0	223.0	197.9	220.0	248.0	338.7	404.0
	60 Hz	Amps	TFD	27.0	31.0	39.0	44.0	49.5	75.0	75.0	99.0	121.4	100.0	125.0	139.0	185.0
			TFC/5	55.0	63.0	77.0	88.0	99.0	123.0	156.0	224.0	199.0	239.0	248.0	338.7	404.0
			TF7	NA	NA	NA	NA	57.0	64.0	70.0	119.6	106.6	145.0	145.0	220.0	220.0
Maximum operating current (MOC)	50 Hz	Amps	TFD	5.0	6.0	6.0	7.1	8.0	10.0	12.5	13.7	16.8	25.0	29.0	30.0	31.0
			TFC/5	10.0	12.0	13.0	14.5	16.0	22.0	25.0	28.8	38.7	51.4	57.7	67.9	31.0
	60 Hz	Amps	TFD	5.0	6.0	6.0	7.1	8.0	10.0	12.5	13.7	16.8	25.0	29.0	30.0	31.0
			TFC/5	10.0	12.0	13.0	14.5	16.0	22.0	25.0	28.8	38.7	51.4	57.7	67.9	31.0
			TF7	NA	NA	NA	NA	10.0	12.0	14.0	17.4	20.9	23.3	27.6	40.6	39.6
Maximum continuous current (MCC)	50 Hz	Amps	TFD	6.0	7.0	6.5	8.0	10.0	12.0	12.5	16.6	20.1	25.0	27.0	28.3	40.0
			TFC/5	13.0	13.5	13.5	16.5	18.5	23.5	28.5	36.3	42.6	52.0	59.0	71.0	82.2
	60 Hz	Amps	TFD	6.0	7.0	7.0	9.0	10.0	12.5	12.5	16.6	20.1	25.0	27.0	28.3	40.0
			TFC/5	13.0	13.5	13.5	17.0	18.5	26.5	30.5	37.4	42.6	52.0	59.0	71.0	82.2
			TF7	NA	NA	NA	NA	11.5	15.9	17.7	19.9	23.8	28.6	30.4	40.5	44.4
Rated load current (RLA=MCC/1.4)	50 Hz	Amps	TFD	4.3	5.0	4.6	5.7	7.1	8.6	8.9	11.9	14.4	17.9	19.3	20.2	28.6
			TFC/5	9.3	9.6	9.6	11.8	13.2	16.8	20.4	25.9	30.4	37.1	42.1	50.7	58.7
	60 Hz	Amps	TFD	4.3	5.0	5.0	6.4	7.1	8.9	8.9	11.9	14.4	17.9	19.3	20.2	28.6
			TFC/5	9.3	9.6	9.6	12.1	13.2	18.9	21.8	26.7	30.4	37.1	42.1	50.7	58.7
			TF7	NA	NA	NA	NA	8.2	11.4	12.6	14.2	17.0	20.4	21.7	28.9	31.7
Rated load current (RLA=MCC/1.56)	50 Hz	Amps	TFD	3.8	4.5	4.2	5.1	6.4	7.7	8.0	10.6	12.9	16.0	17.3	18.1	25.6
			TFC/5	8.3	8.7	8.7	10.6	11.9	15.1	18.3	23.3	27.3	33.3	37.8	45.5	52.7
	60 Hz	Amps	TFD	3.8	4.5	4.5	5.8	6.4	8.0	8.0	10.6	12.9	16.0	17.3	18.1	25.6
			TFC/5	8.3	8.7	8.7	10.9	11.9	17.0	19.6	24.0	27.3	33.3	37.8	45.5	52.7
			TF7	NA	NA	NA	NA	7.4	10.2	11.3	12.8	15.3	18.3	19.5	26.0	28.5
Winding resistance at 25°C	Ohm	TFD	7.15	5.94	4.83	4.03	3.64	2.75	2.27	1.74	1.63	1.24	1.24	1.09	0.78	
		TFC/5	1.79	1.46	1.23	1.00	0.91	0.69	0.56	0.39	0.37	0.31	0.28	0.22	0.18	
		TF7	NA	NA	NA	NA	2.78	2.23	1.92	1.20	1.06	0.85	0.85	0.56	0.56	
Connection size	Rotalock connection															
	Suction	in	1 1/4	1 1/4	1 1/4	1 1/4	1 1/4	1 1/4	1 1/4	1 1/4	1 1/4	1 1/4	1 3/4	1 3/4	1 3/4	1 3/4
	Discharge	in	1	1	1	1	1	1	1	1	1 1/4	1 1/4	1 1/4	1 1/4	1 1/4	1 1/4
	Injection	in	11/16	11/16	11/16	11/16	11/16	11/16	11/16	11/16	11/16	11/16	1	1	1	1
	Brazing connection															
	Suction	in	7/8	7/8	7/8	7/8	7/8	7/8	7/8	7/8	7/8	7/8	1 3/8	1 3/8	1 3/8	1 3/8
Discharge	in	1/2	1/2	1/2	1/2	1/2	1/2	1/2	1/2	1/2	3/4	3/4	7/8	7/8	7/8	7/8
Injection	in	11/16 (Rotalock only)										1 (Rotalock only)				
Outline dimension	Length	mm	246	246	246	246	246	246	246	246	246	280	280	280	280	
	Width	mm	246	246	246	246	257	257	257	257	257	280	280	280	280	
	Height	mm	369	391	391	405	442	442	442	442	451	534	534	552	552	
Sight glass fitting thread	in	1 1/4"-12UNF					1 1/4"-12UNF					1 1/4"-12UNF				
Oil quantity	L	1.3	1.5	1.5	1.5	1.9	1.9	1.9	1.9	1.9	3.4	3.4	3.4	3.4		
Net weight	kg	25	27	27	29	39	39	39	39	40	63	63	66	66		
Terminal box IP grade		IP21					IP21 (Except ZF28KQE-TFC with IP54)					IP54				
Crankcase heater power	W	70					70					90				
Mounting parts installation size (hole size)	mm	190 x 190 (Ø19)														

# Technical data

Compressor model			Vapor injection												
			ZFI20KQE	ZFI23KQE	ZFI26KQE	ZFI36KQE	ZFI39KQE	ZFI50KQE	ZFI59KQE	ZFI68KQE	ZFI81KQE	ZFI96KQE	ZFI122KQE	ZFI140KQE	
Nominal horsepower		hp	4	5	6	8	10	12	15	18	20	25	30	40	
Displacement	50 Hz	m³/hr	11.7	14.4	17.1	21.4	25.1	29.1	35.3	42.4	48.3	60.7	77.3	87.5	
	60 Hz		14.1	17.4	20.6	25.8	30.3	35.1	42.6	51.2	58.3	73.3	93.3	105.5	
Motor type	50 Hz		TFD	TFD	TFD	TFD	TFD	TFD	TFD	TFD	TFD	TED	TED	TED	
			TFC	TFC	TFC	TFC	TFC	TFC	TFC	TFC	TFC	TFC	TEC	TEC	TEC
	60 Hz		TFD	TFD	TFD	TFD	TFD	TFD	TFD	TFD	TFD	TED	TED	TED	
			TFC	TFC	TFC	TFC	TFC	TFC	TFC	TFC	TFC	TFC	TEC	TEC	TEC
Locked rotor current (LRA)	50 Hz	Amps	TFD	64.0	74.0	74.0	102.0	121.4	100.0	118.0	139.0	168.0	246.5	310.0	310.0
			TFC	135.0	163.4	172.0	223.0	197.9	220.0	248.0	338.7	404.0	599.0	599.0	599.0
	60 Hz	Amps	TFD	62.0	75.0	70.0	99.0	121.4	100.0	125.0	139.0	185.0	272.4	310.0	310.0
			TFC	123.0	170.9	156.0	224.0	199.0	239.0	248.0	338.7	404.0	599.0	599.0	599.0
Maximum operating current (MOC)	50 Hz	Amps	TFD	9.0	12.4	13.7	16.0	18.1	25.0	29.0	30.0	31.0	41.5	53.6	56.3
			TFC	18.0	23.6	26.0	36.7	37.2	51.4	57.7	67.9	31.0	81.4	101.6	112.6
	60 Hz	Amps	TFD	9.0	12.4	13.7	16.0	18.1	25.0	29.0	30.0	31.0	41.5	53.6	56.3
			TFC	18.0	26.5	26.0	36.7	37.2	51.4	57.7	67.9	31.0	81.4	101.6	112.6
Maximum continuous current (MCC)	50 Hz	Amps	TFD	12.0	13.6	13.0	16.6	20.3	25.0	27.0	28.3	40.0	52.0	65.4	67.8
			TFC	24.0	24.8	28.5	35.3	42.6	52.0	59.0	71.0	82.2	123.3	119.7	145.0
	60 Hz	Amps	TFD	12.0	14.0	13.0	18.5	20.3	25.0	27.0	28.3	40.0	55.0	71.7	72.7
			TFC	24.0	25.5	30.5	38.2	42.6	52.0	59.0	71.0	82.2	124.4	140.0	145.0
Rated load current (RLA=MCC/1.4)	50 Hz	Amps	TFD	8.6	9.7	9.3	11.9	14.5	17.9	19.3	20.2	28.6	37.1	46.7	48.4
			TFC	17.1	17.7	20.4	25.2	30.4	37.1	42.1	50.7	58.7	88.1	85.5	103.6
	60 Hz	Amps	TFD	8.6	10.0	9.3	11.9	14.5	17.9	19.3	20.2	28.6	39.3	51.2	51.9
			TFC	17.1	18.2	21.8	27.3	30.4	37.1	42.1	50.7	58.7	88.9	100.0	103.6
Rated load current (RLA=MCC/1.56)	50 Hz	Amps	TFD	7.7	8.7	8.3	10.6	13.0	16.0	17.3	18.1	25.6	33.3	41.9	43.5
			TFC	15.4	15.9	18.3	22.6	27.3	33.3	37.8	45.5	52.7	79.0	76.7	92.9
	60 Hz	Amps	TFD	7.7	9.0	8.3	10.6	13.0	16.0	17.3	18.1	25.6	35.3	46.0	46.6
			TFC	15.4	16.3	19.6	24.5	27.3	33.3	37.8	45.5	52.7	79.7	89.7	92.9
Winding resistance at 25°C	Ohm	TFD	2.75	2.27	2.27	1.74	1.63	1.24	1.24	1.09	0.78	0.58	0.36	0.36	
		TFC	0.69	0.50	0.56	0.39	0.37	0.31	0.28	0.22	0.18	0.09	0.09	0.09	
		TF7	2.23	1.64	1.92	1.20	1.06	0.85	0.85	0.56	0.56	0.42	0.25		
Connection size	Rotalock connection														
	Suction	in	1 1/4	1 1/4	1 1/4	1 1/4	1 1/4	1 3/4	1 3/4	1 3/4	1 3/4	2 1/4	2 1/4	2 1/4	
	Discharge	in	1	1	1	1 1/4	1 1/4	1 1/4	1 1/4	1 1/4	1 1/4	1 3/4	1 3/4	1 3/4	
	Injection	in	1	1	1	1	1	1	1	1	1	1	1	1	
	Brazing connection														
	Suction	in	7/8	7/8	7/8	7/8	7/8	1 3/8	1 3/8	1 3/8	1 3/8	1 5/8	1 5/8	1 5/8	
Discharge	in	1/2	1/2	1/2	3/4	3/4	7/8	7/8	7/8	7/8	1 3/8	1 3/8	1 3/8		
Injection	in	1/2	1/2	1/2	1/2	1/2	5/8	5/8	5/8	5/8	3/4	3/4	3/4		
Outline dimension	Length	mm	246	246	246	246	246	328	328	328	328	448	448	448	
	Width	mm	257	257	257	257	257	297	297	297	297	409.3	409.3	409.3	
	Height	mm	442	442	442	442	451	534	534	552	552	715	715	715	
Sight glass fitting thread	in	1 1/4"-12UNF									1 3/4" x 12UNF				
Oil quantity	L	1.9	1.9	1.9	1.9	1.9	3.4	3.4	3.4	3.4	6.3	6.3	6.3		
Net weight	kg	39	39	39	39	40	63	63	66	66	176.9	179.2	179.2		
Terminal box IP grade		IP21 (Except ZFI39KQE-TFC with IP54)						IP54				IP56			
Crankcase heater power	W	70						90				150			
Mounting parts Installation size (hole size)	mm	190 x 190 (Ø19)									266.7 x 266.7 (Ø22.6)				

# EVI CoreSense control kits and wiring diagram

## EVI CoreSense control kits

### Introduction

The EVI CoreSense control kit of ZFI compressor is intended to control vapor injection, maintain a safe discharge temperature, and provide intelligent diagnosis and protection.

The kit includes a printed circuit board (PCB), an electronic expansion valve (EXV), and three sensors, as well as containing a transformer and an EXV filter. All parts are common, except the EXV valve orifice size, which will be applied to different ZFI models.

In vapor injection application, the valve is driven by sensors mounted near the heat exchanger and attempts to maintain the vapor outlet sensor 5K higher than the vapor inlet. The system will switch to discharge line temperature control if vapor injection is insufficient to maintain a safe discharge temperature. If the discharge temperature becomes dangerously high, the system will stop the compressor, turn on an LED alarm, and trigger a voltage free alarm relay contact. The compressor can auto-reset, but not lockout.

Emerson provides customer EVI CoreSense control kits with and without CoreSense box.

EVI CoreSense control kits			
Part number without CoreSense box	Part number with CoreSense box	Apply for ZFI models	EXV valve orifice size (Identification code)
562-0313-00	562-0291-01	ZFI20~ZFI26	Ø1.3mm (TS113C03)
562-0313-01	562-0291-02	ZFI36~ZFI59	Ø1.65mm (TS116C03)
562-0313-02	562-0291-03	ZFI68~ZFI81	Ø1.8mm (TS118C03)
562-0313-03	562-0291-06	ZFI96~ZFI140	Ø2.4mm (TS124C03)

### Printed circuit board

Wear a ground strap when working with the PCB to avoid the risk of damage from static discharges.

General PCB layout, input and output ports are shown in the image below, the ports to EXV, DLT, as well as the vapor in and vapor out sensors are done with Poka-yoke connector design. Connect sensors, EXV, and system wiring as shown in wiring diagram.

The PCB is supplied power through a transformer with a power input of 50/60 Hz, 220VAC, and an output of 12VAC to the PCB board.

For EVI control kits with CoreSense box, the board and transformer are both mounted in the box, using 4 x Ø5mm holes at 61 x 101mm centers, fastened by screws. Spare part number is 543-0189-01 for field service.

For EVI control kits without CoreSense box, we provide individual parts for compact system design. The board is with 4 x Ø4mm holes at 61 x 101mm centers, please use plastic stakes provided. Spare part number is 543-0219-01 for field service.

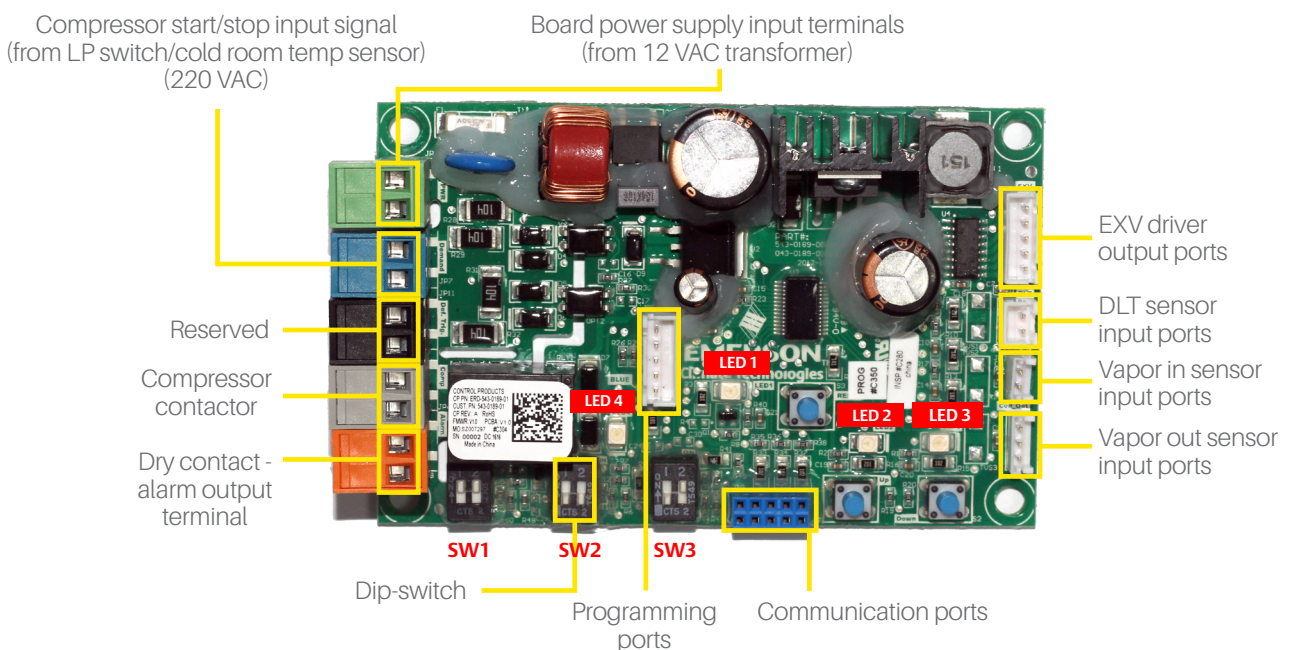

## Dip-switch setting

The dip-switch default setting has been done in-factory, please do not change setting and ensure that the replacement board is set correctly.

For the glide-refrigerants application like R407A, R407F, R407C, we would recommend 10K superheat. Please contact your local Emerson sales and application engineer to reset the dip-switch.

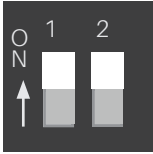
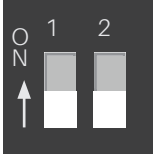
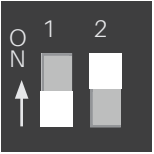
Dip-switch default factory setting			
	SW1	SW2	SW3
BIT1	ON	OFF	OFF
BIT2	ON	OFF	ON
Dip-switch Setting position			
Function description of default setting	<ol style="list-style-type: none"> <li>1. Discharge Line Temperature (DLT) control target <math>\leq 110^{\circ}\text{C}</math></li> <li>2. Vapor out superheat target is 5K</li> <li>3. Compressor will shut down if DLT above <math>125^{\circ}\text{C}</math></li> <li>4. Compressor can auto-reset and no lockout due to DLT overheat protection</li> <li>5. Compressor minimum stop time is 0 minute</li> <li>6. Vapor injection mode</li> </ol>		

## LED functions

### LED1 (yellow-green)

LED1 will light up during initialization after power on, after that, blinking lights will indicate the sensor status.

LED	Color	Compressor or sensor status	LED1 behavior
LED1	Yellow-Green	Idle compressor waiting to start	Blinks at 1 Hz
		DLT overheat protection	Blinks 2 times at 1 Hz, waiting 5s, then repeat...
		DLT failure	Blinks 3 times at 1 Hz, waiting 5s, then repeat...
		Vapor in sensor failure	Blinks 4 times at 1 Hz, waiting 5s, then repeat...
		Vapor out sensor failure	Blinks 5 times at 1 Hz, waiting 5s, then repeat...

### LED2, LED3 (yellow-green)

LED2 and LED3 will blink once when entering or exiting EXV manual operation, and also indicate EXV opening and closing.

LED	Color	EXV status	LED2, LED3 behavior
LED2 LED3	Yellow-Green	Opening	LED2 is flashing at 1 Hz, LED3 off
		Closing	LED3 is flashing at 1 Hz, LED2 off
		Fully open	LED2 constant on, LED3 off
		Fully closed	LED3 constant on, LED2 off

**LED4** (red color) alarm

**LED4** will turn on when alarm is triggered by the following items

LED	Color	Sensor status	LED4 behavior
LED4	Red	DLT overheat protection	LED4 on, red color
		DLT sensor failure	LED4 on, red color
		Vapor in sensor failure	LED4 on, red color
		Vapor out sensor failure	LED4 on, red color

## Temperature sensors

The EVI kits include 3 temperature sensors. Please ensure all sensors are mounted in the correct locations, fastened, and insulated properly.

The discharge temperature sensor should be installed approximately 178mm (7 inches) from discharge tube outlet. If a service valve is installed at the discharge tube, the sensor should be located 127mm (5 inches) from the valve braze.

The vapor-in sensor is connected to the pipe between the EXV and PHE. The vapor-out sensor is connected to the pipe from the PHE to the compressor vapor injection port. Don't make the vapor-in and vapor-out sensor location reversed.

Sensor	Wire length	Resistance value vs. temperature	Open	Short
Discharge temperature sensor	1800mm	351.6 kΩ @0°C 100.0 kΩ @25°C 5.8 kΩ @100°C	> 1000kΩ	<400Ω
Vapor-in sensor	1800mm	28.1 kΩ @0°C 10.0 kΩ @25°C 0.9 kΩ @100°C	>500kΩ	<500Ω
Vapor-out sensor	1800mm	28.1 kΩ @0°C 10.0 kΩ @25°C 0.9 kΩ @100°C	>500kΩ	<500Ω

## Electronic expansion valve (EXV)

The EXV contains an EXV-valve and EXV-coil, lead wire length for coil is 1796mm, the valve size includes Ø1.3mm, Ø1.65mm and Ø2.4mm depending on system size, applied to different ZFI models.

The liquid refrigerant should pass from the bending tube and flow out from the straight tube. Please weld the filter before the EXV provided along with the kits.

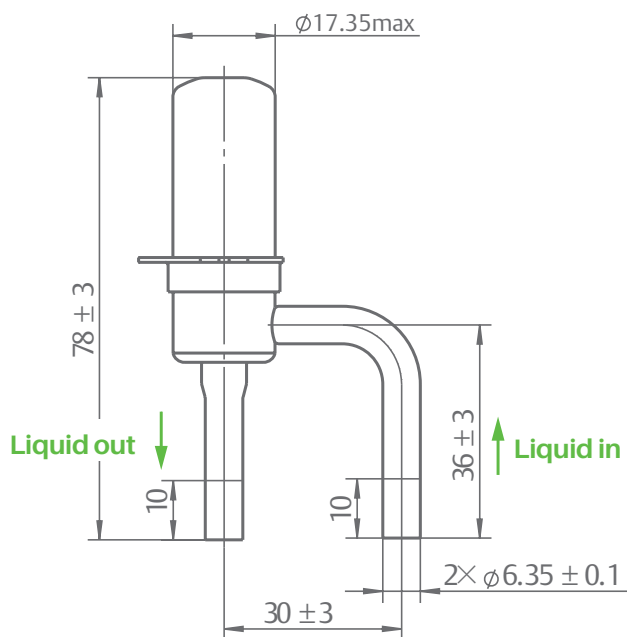

EXV valve connection size, mm

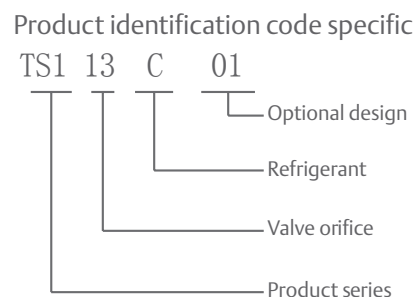
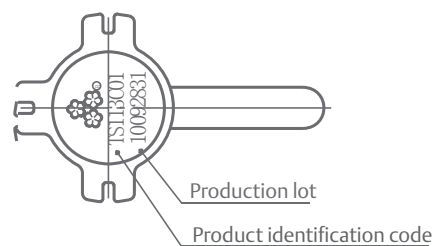

EXV valve identification code

## ZFI standard control box wiring example

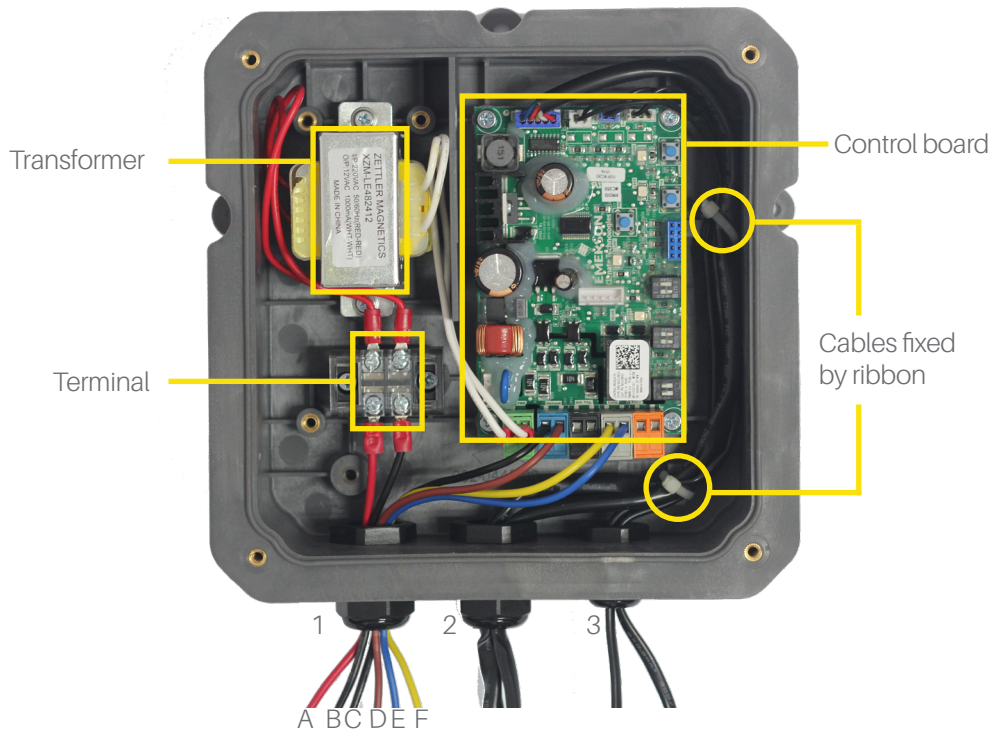

Waterproof gland no.	Gland 1	Gland 2	Gland 3
Wire function	A (red) and B (black): Controller power supply input (220–240 VAC 50/60 Hz)	EXV Coil DLT Sensor	Vapor-in sensor Vapor-out sensor
	C (black) and D (brown): Compressor start/stop input (220–240 VAC 50/60 Hz)		
	E (blue) and F (yellow): Compressors contactor coil Control output		
Wire connection	Wires A and B: Connect to terminal	Connect to the EXV, DLT sensor at the top edge of the control board	Connect to the vapor-in/out port at the top edge of the control board
	Wires C and D: Connect to the blue connector on the control board		
	Wires E and F: Connect to the gray connector on the control board		
Gland internal diameter range	2–3 mm		
Jacket line requirement	Internal wire size: 18 AWG		
	Rated voltage: 300 V/600 V		
	Rated temperature: 80/105 °C		
	Recommended: UL105, UL1011, UL1007		

## Plate heat exchanger (PHE) and liquid line temperature

Mount plate heat exchanger in the vertical position and oriented correctly. Ensure that sensors are located correctly as well.

ZFI vapor injection compressors can deliver very cold liquid with economizer cycle. The sub-cooling of liquid line calls for these recommendations:

1. Liquid line pipe connecting the economizer to the evaporator expansion valve should be well-insulated separately.
2. The lower liquid line temperature can increase the evaporator valve capacities. Please follow the valve manufacturer's recommended liquid temperature correction factors for proper selection of evaporator expansion valve. Refer to product catalogue or select software for liquid line temperature.

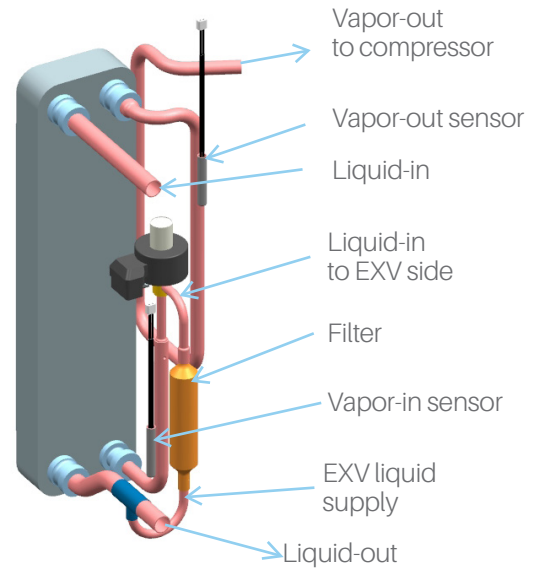

Example of PHE assembly with downstream liquid supply

## Wiring diagram

### ZFI 20 - ZFI81

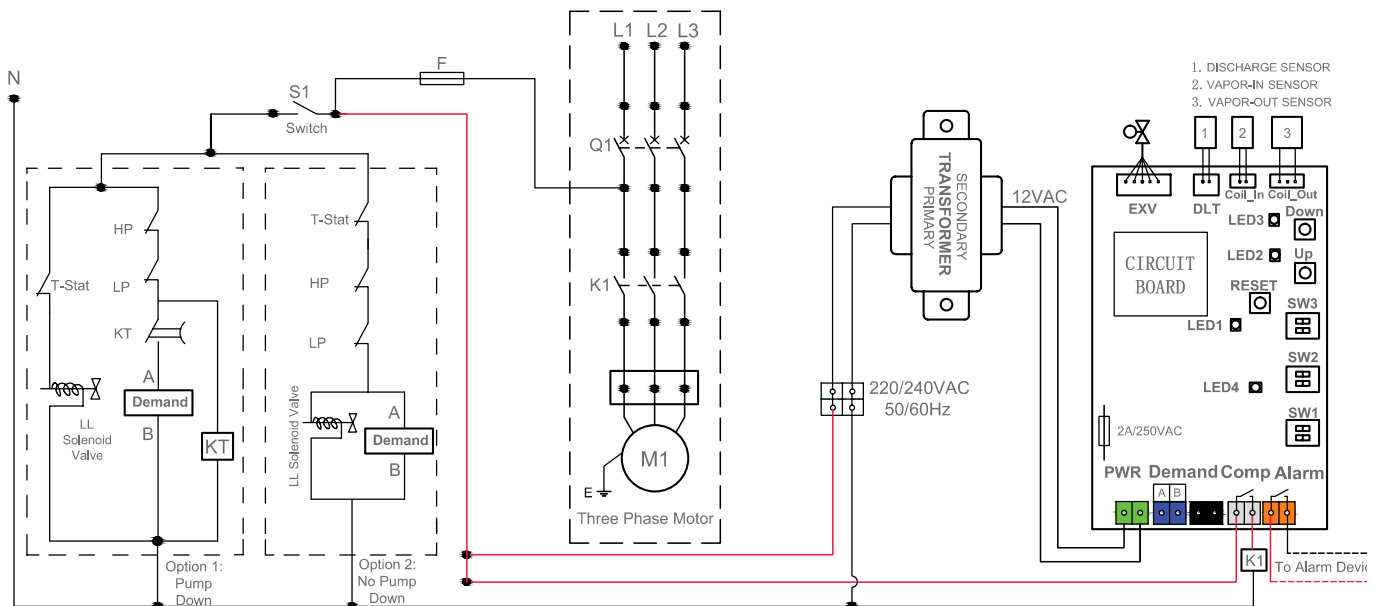

- K1 - Contactor
- Q1 - Breaker
- KT - Time Delay Relay
- Demand - On/Off Signal

#### Check List:

1. Check Wiring Of Controller Power Supplier
2. Check Wiring Of Compressor Terminal
3. Check Wiring Of Demand Terminal
4. Check Wiring Of Temperature Sensor Terminal
5. Check Wiring Of EXV Terminal

	STATUS	NOTES
LED 1	Blinks At 1 Hz	Compressor Waiting To Start
	Blinks 2 Times At 1 Hz, Waiting 5s, Then Repeat	DLT Over-Heating
	Blinks 3 Times At 1 Hz, Waiting 5s, Then Repeat	DLT Sensor Failure
	Blinks 4 Times At 1 Hz, Waiting 5s, Then Repeat	Vapor In Sensor Failure
	Blinks 5 Times At 1 Hz, Waiting 5s, Then Repeat	Vapor Out Sensor Failure
LED2 LED3	LED2 Flashing At 1 Hz, LED3 Off	EXV Opening
	LED3 Flashing At 1 Hz, LED2 Off	EXV Closing
	LED2 On, LED3 Off	EXV Fully Open
	LED3 On, LED2 Off	EXV Fully Close
LED4	Constant On	DLT Over-Heating Protection
		DLT Sensor Failure Or Vapor In Sensor Failure Or Vapor Out Sensor Failure



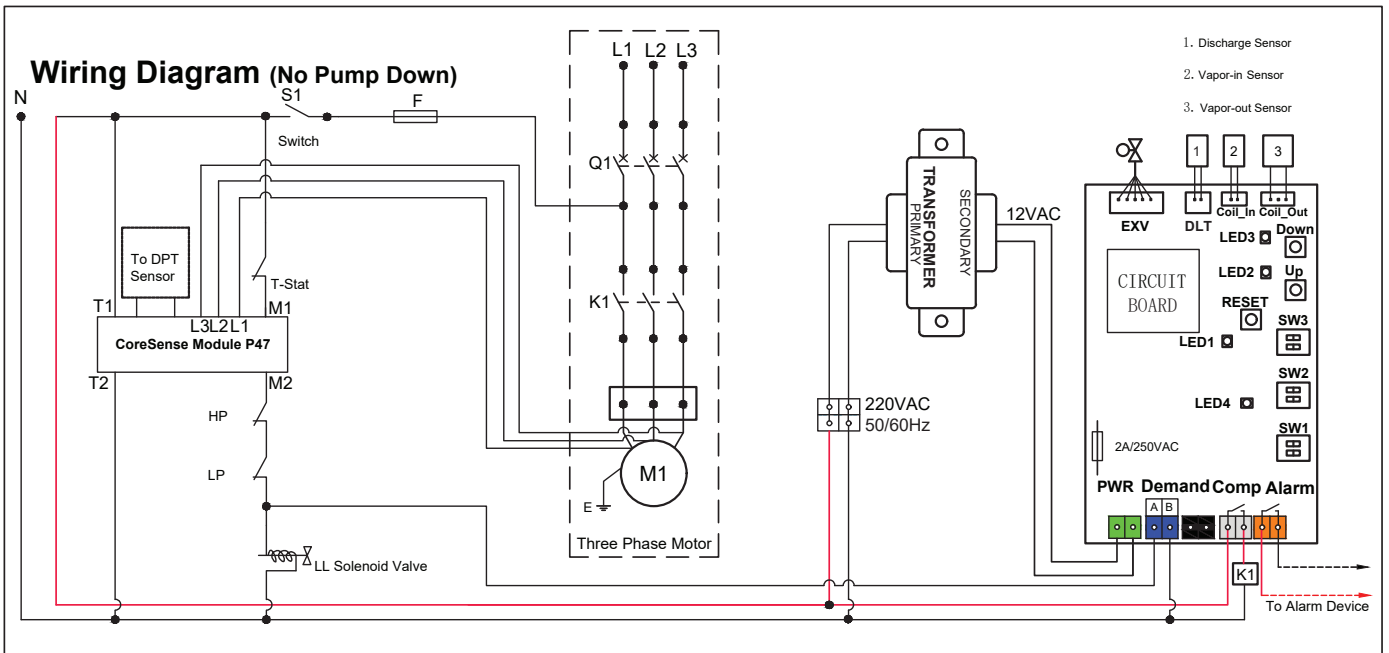
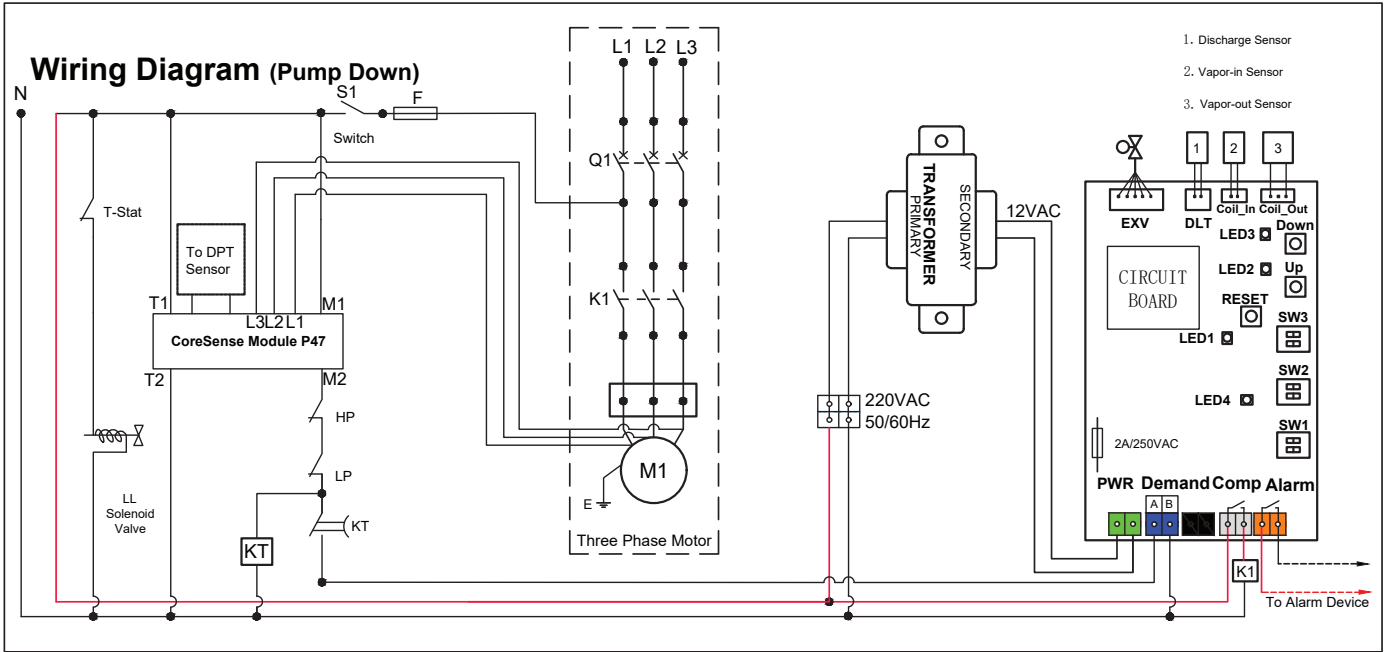

# Dimensional drawings

## ZF06KQE - ZF11KQE (BOM 551)

### Rotalock connection

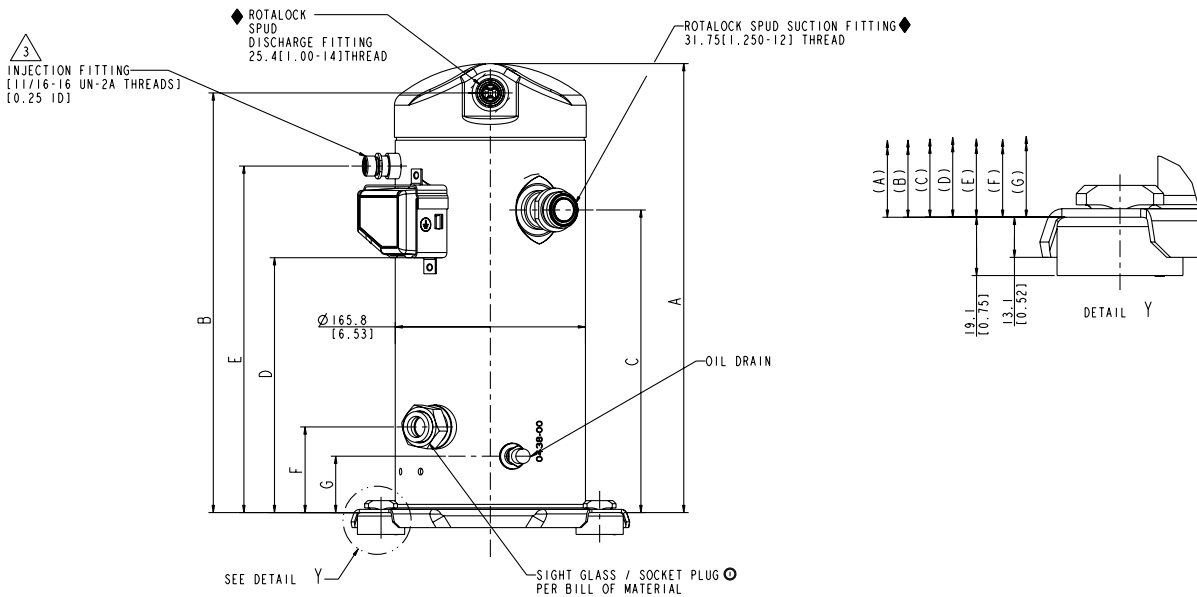
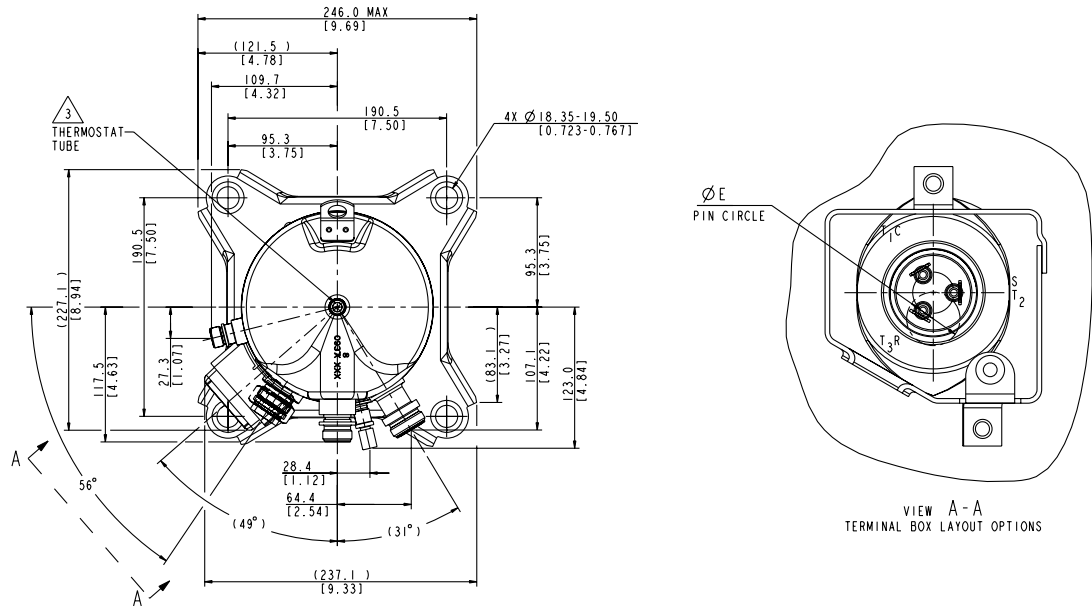

Model number	mm[in]						
	A±3.0	B	C	D±3.0	E	F	G
ZF06KQE	368.7 [14.52]	343.1 [13.51]	243.8 [9.60]	202.2 [7.96]	279.4 [11.00]	68.9 [2.71]	43.4 [1.70]
ZF08KQE	391.3 [15.41]	365.7 [14.40]	263.7 [10.38]	222.1 [8.74]	302.0 [11.88]	74.6 [2.93]	49.1 [1.93]
ZF09KQE	391.3 [15.41]	365.7 [14.40]	263.7 [10.38]	222.1 [8.74]	302.0 [11.88]	74.6 [2.93]	49.1 [1.93]
ZF11KQE	405.0 [15.94]	379.4 [14.94]	276.4 [10.88]	234.8 [9.24]	315.7 [12.42]	74.6 [2.93]	49.1 [1.93]

**Notes:**

- (1) All tolerances ± 1.5mm [0.06in] unless otherwise specified
- (2) Due to accumulated assembly tolerances, the listed components may vary from the mounting holes. All fittings: ± 3.0mm [0.12in]
- (3) Tube ends must be plugged
- (4) All units are in mm[inch]

# Dimensional drawings

## ZF13KQE - ZF28KQE (BOM 551)

### Rotalock connection

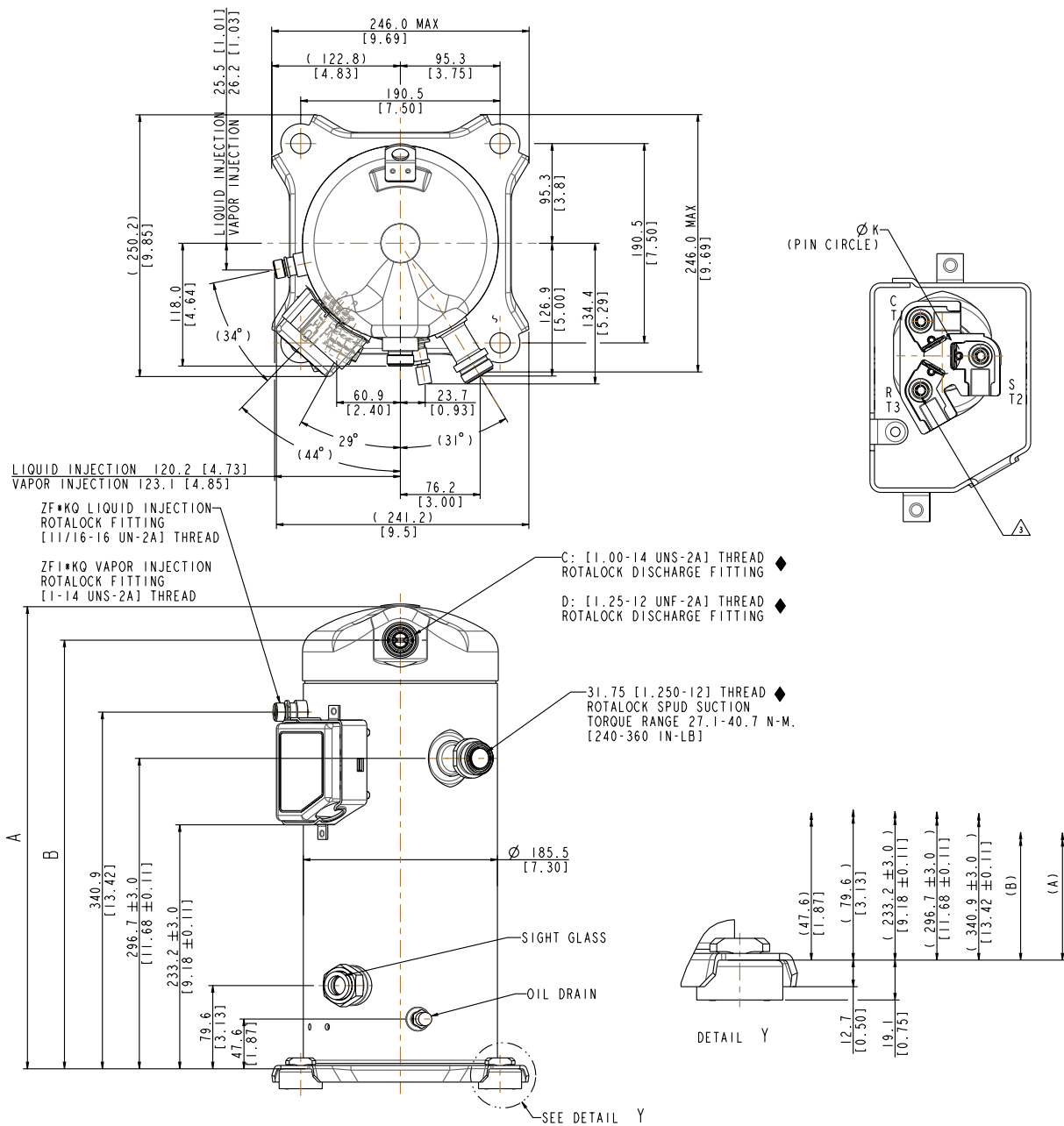

Model number	mm (in)		Discharge fitting
	A±3.0	B±3.0	
ZF13KQE	442.0 [17.40]	409.6 [16.13]	C
ZF15KQE			
ZF18KQE			
ZF25KQE			D
ZF28KQE	451.0 [17.76]	418.6 [16.48]	D

**Notes:**

- (1) All tolerances ± 1.5mm [0.06in] unless otherwise specified
- (2) Due to accumulated assembly tolerances, the listed components may vary from the mounting holes. All fittings: ± 3.0mm [0.12in]
- (3) Tube ends must be plugged
- (4) All units are in mm[inch]

# Dimensional drawings

## ZFI20KQE - ZFI39KQE (BOM 552)

### Rotalock connection

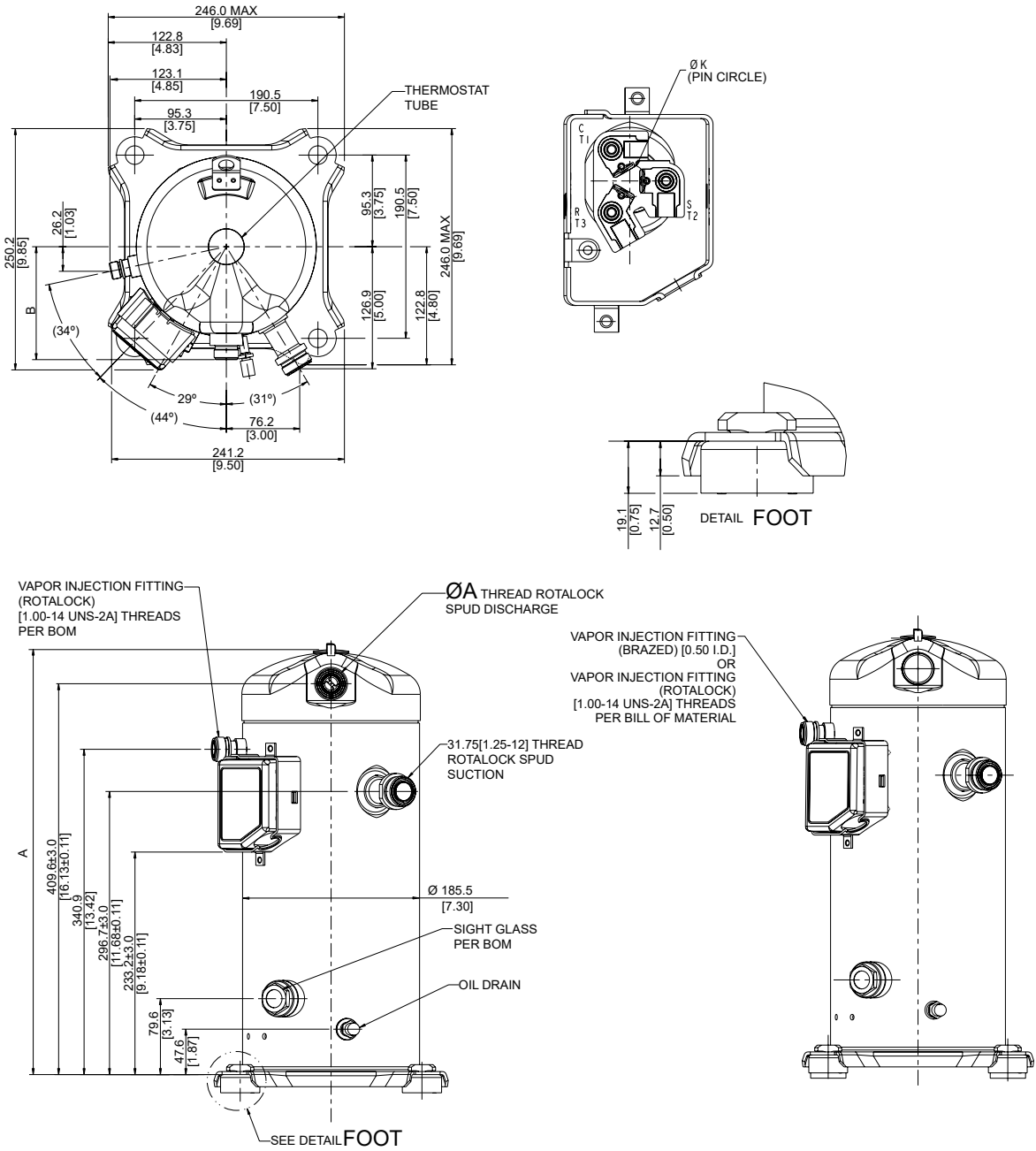

Model number	mm (in)		Discharge fitting
	A±3.0	B	
ZFI20KQE	442.0 [17.40]	409.6 [16.13]	C
ZFI23KQE			
ZFI26KQE			D
ZFI36KQE			
ZFI39KQE	451.0 [17.76]	418.6 [16.48]	D

**Notes:**

- (1) All tolerances ± 1.5mm [0.06in] unless otherwise specified
- (2) Due to accumulated assembly tolerances, the listed components may vary from the mounting holes. All fittings: ± 3.0mm [0.12in]
- (3) Tube ends must be plugged
- (4) All units are in mm[inch]

# Dimensional drawings

## ZF34KQE - ZF54KQE (BOM 564/567)

### Rotalock connection

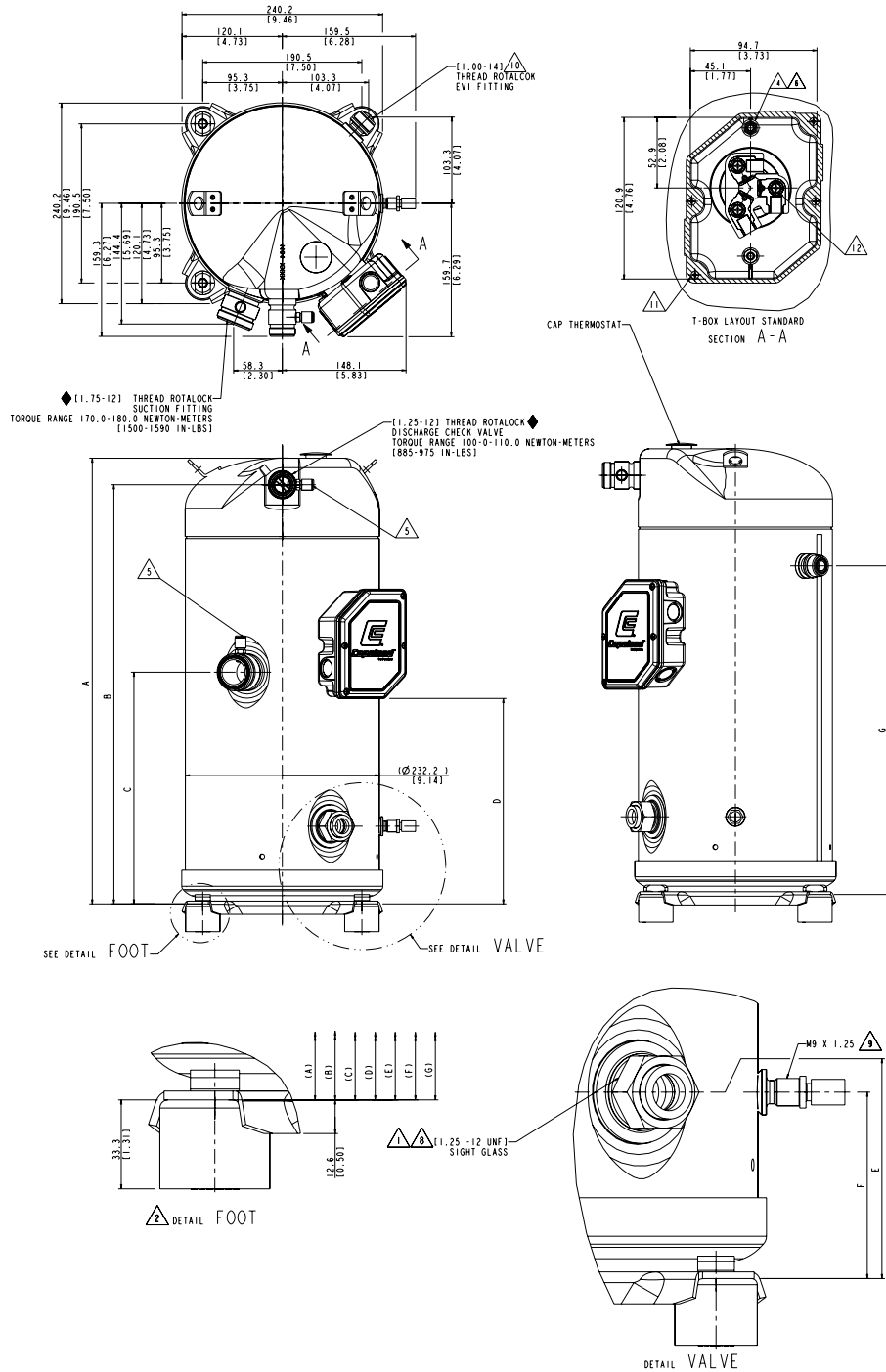

Model number	mm (in)						
	A	B	C	D	E	F	G
ZF34KQE	533.6	501.8	277.3	245.7	93.0	93.0	393.3
ZF41KQE	[21.0]	[19.75]	[10.91]	[9.67]	[3.66]	[3.66]	[15.49]
ZF49KQE	551.5	519.5	295.0	263.6	92.6	92.6	441.0
ZF54KQE	[21.7]	[20.45]	[11.61]	[10.37]	[3.64]	[3.64]	[16.18]

#### Notes:

- (1) All tolerances  $\pm 1.5\text{mm}$  [0.06in] unless otherwise specified
- (2) Due to accumulated assembly tolerances, the listed components may vary from the mounting holes. All fittings:  $\pm 3.0\text{mm}$  [0.12in]
- (3) Tube ends must be plugged
- (4) All units are in mm[inch]

# Dimensional drawings

## ZFI50KQE - ZFI81KQE (BOM 564/567)

### Rotalock connection

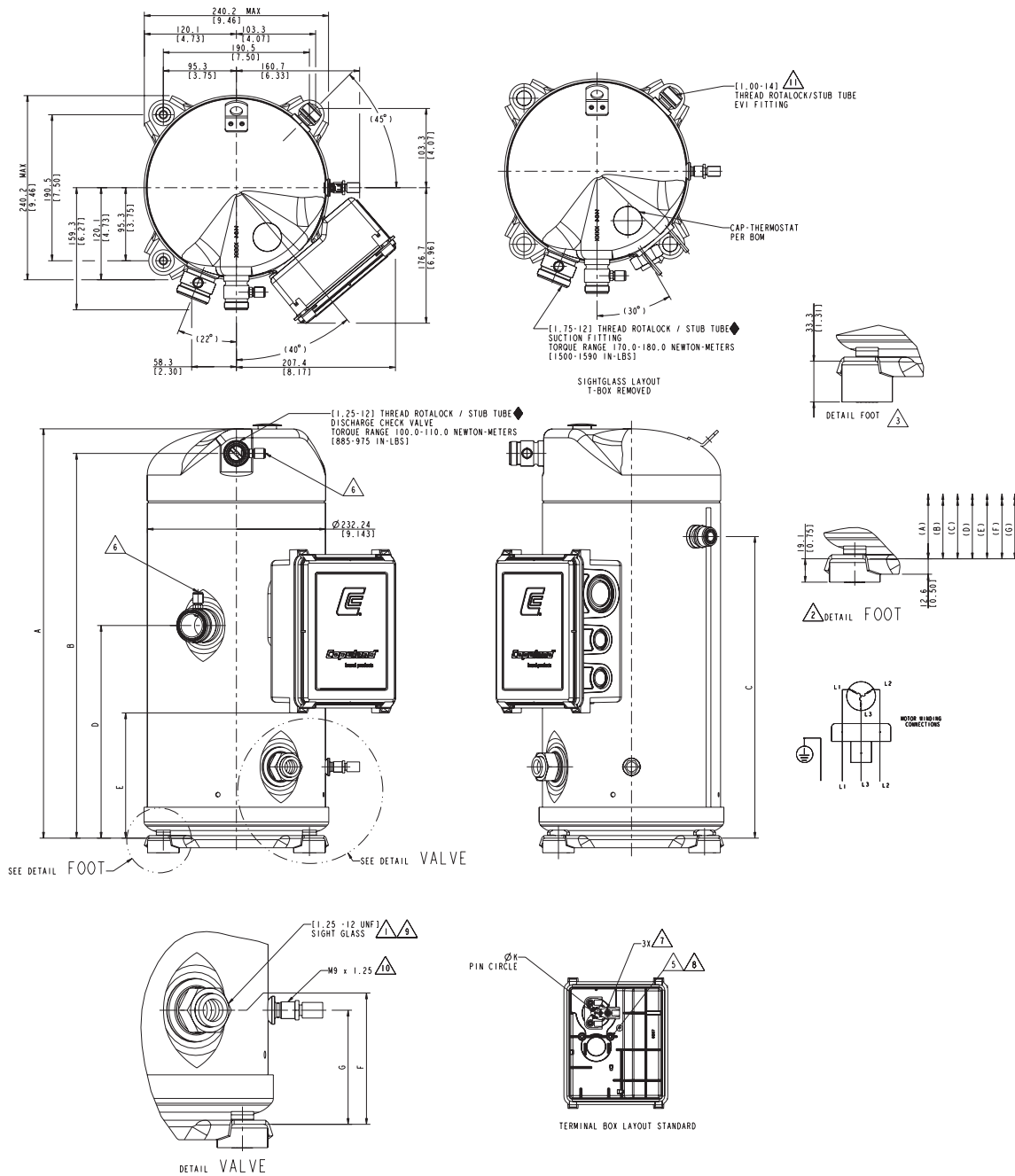

Model number	mm (in)							ØK
	A	B	C	D	E	F	G	
ZFI50KQE	533.6 [21.01]	501.8 [19.76]	393.3 [15.48]	277.3 [10.92]	163.3 [6.43]	93.0 [3.66]	93.0 [3.66]	17.45 [0.687]
ZFI59KQE								
ZFI68KQE	551.5 [21.71]	519.5 [20.45]	411.0 [16.18]	295.0 [11.61]	163.3 [6.43]	92.6 [3.64]	92.6 [3.64]	20.70 [0.815]
ZFI81KQE								

**Notes:**

- (1) All tolerances ± 1.5mm [0.06in] unless otherwise specified
- (2) Due to accumulated assembly tolerances, the listed components may vary from the mounting holes. All fittings: ± 3.0mm [0.12in]
- (3) Tube ends must be plugged
- (4) All units are in mm[inch]

# Dimensional drawings

## ZF06KQE - ZF11KQE (BOM 550)

### Stub tube connection

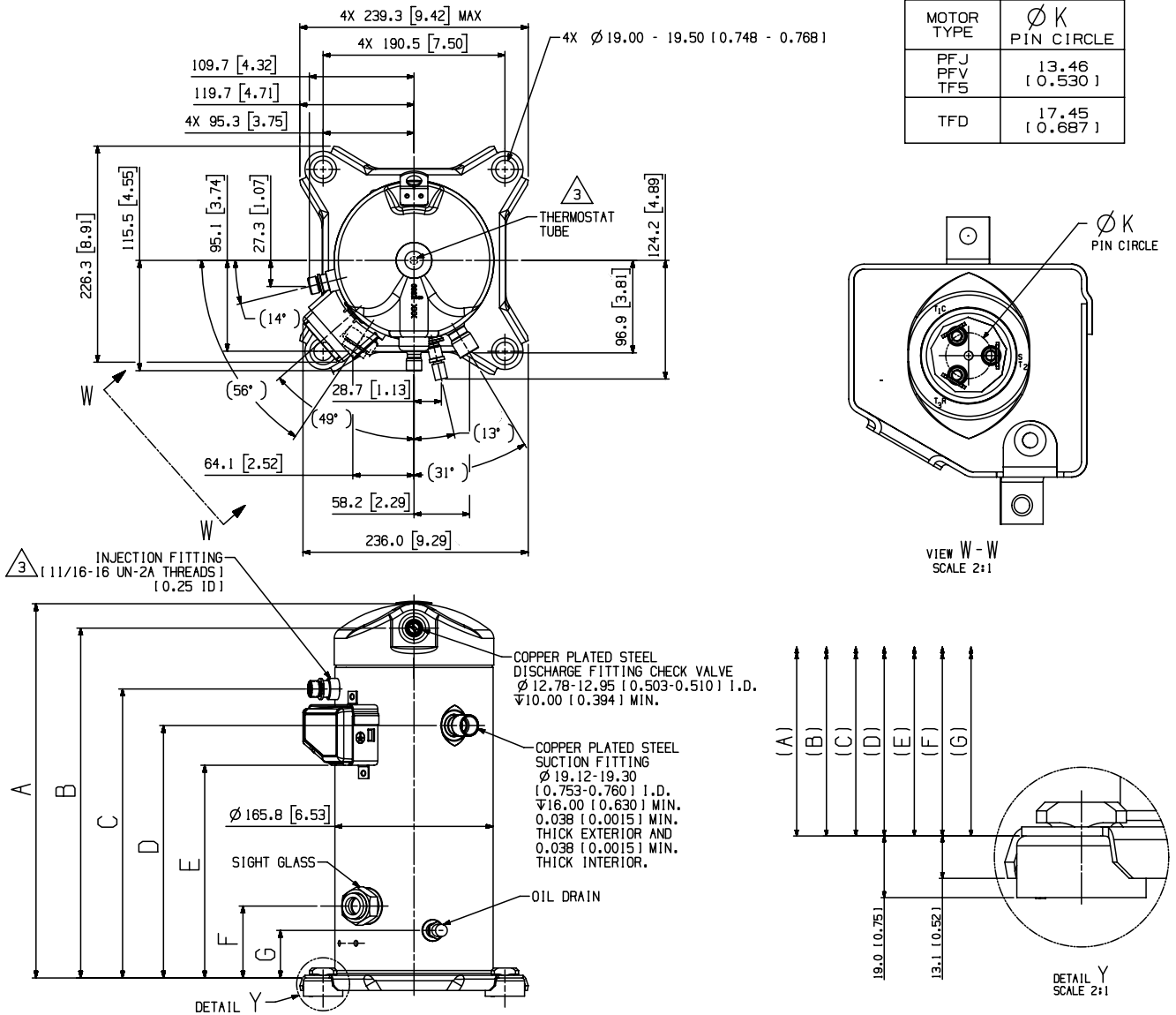

Model number	mm (in)						
	A	B	C	D	E	F	G
ZF06KQE	369.9 [14.56]	343.8 [13.54]	280.0 [11.02]	244.5 [9.62]	202.9 [7.99]	69.6 [2.74]	44.1 [1.74]
ZF08KQE ZF09KQE	392.5 [15.45]	366.4 [14.42]	302.6 [11.91]	264.4 [10.41]	222.8 [8.77]	75.3 [2.96]	49.8 [1.96]
ZF11KQE	406.3 [16.00]	380.1 [14.96]	316.4 [12.46]	277.1 [10.91]	235.5 [9.27]	75.3 [2.96]	49.8 [1.96]

#### Notes:

- (1) All tolerances  $\pm 1.5\text{mm}$  [0.06in] unless otherwise specified
- (2) Due to accumulated assembly tolerances, the listed components may vary from the mounting holes. All fittings:  $\pm 3.0\text{mm}$  [0.12in]
- (3) Tube ends must be plugged
- (4) All units are in mm[inch]

# Dimensional drawings

## ZF13KQE - ZF28KQE (BOM 550)

### Stub tube connection

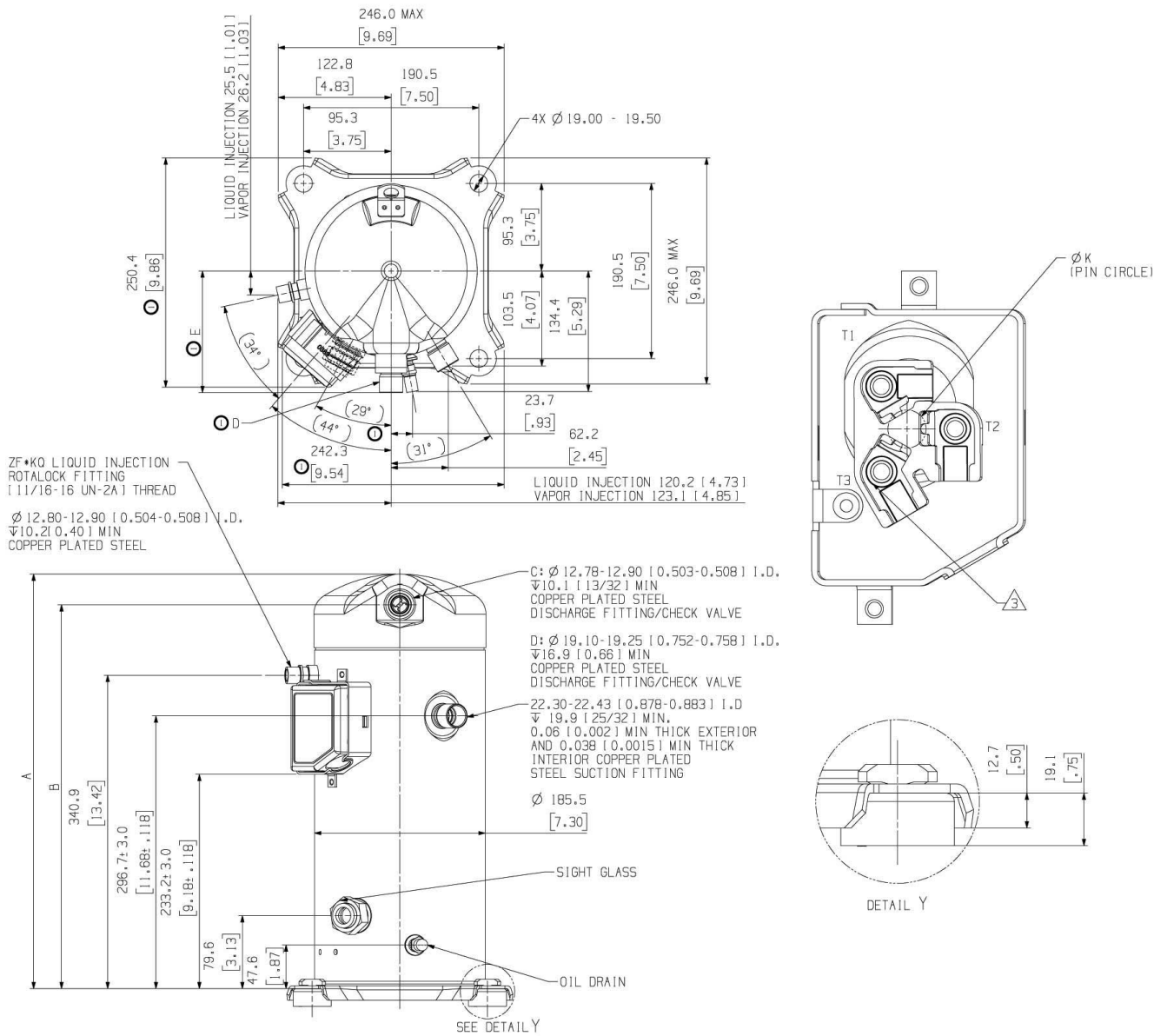

Model number	mm (in)		Discharge fitting
	A±3.0	B±3.0	
ZF13KQE	442.0 [17.40]	409.6 [16.13]	C
ZF15KQE			
ZF18KQE			
ZF25KQE			D
ZF28KQE	451.0 [17.76]	418.6 [16.48]	D

**Notes:**

- (1) All tolerances ± 1.5mm [0.06in] unless otherwise specified
- (2) Due to accumulated assembly tolerances, the listed components may vary from the mounting holes. All fittings: ± 3.0mm [0.12in]
- (3) Tube ends must be plugged
- (4) All units are in mm (inch)





# Dimensional drawings

## ZFI20KQE - ZFI39KQE (BOM 550)

### Stub tube connection

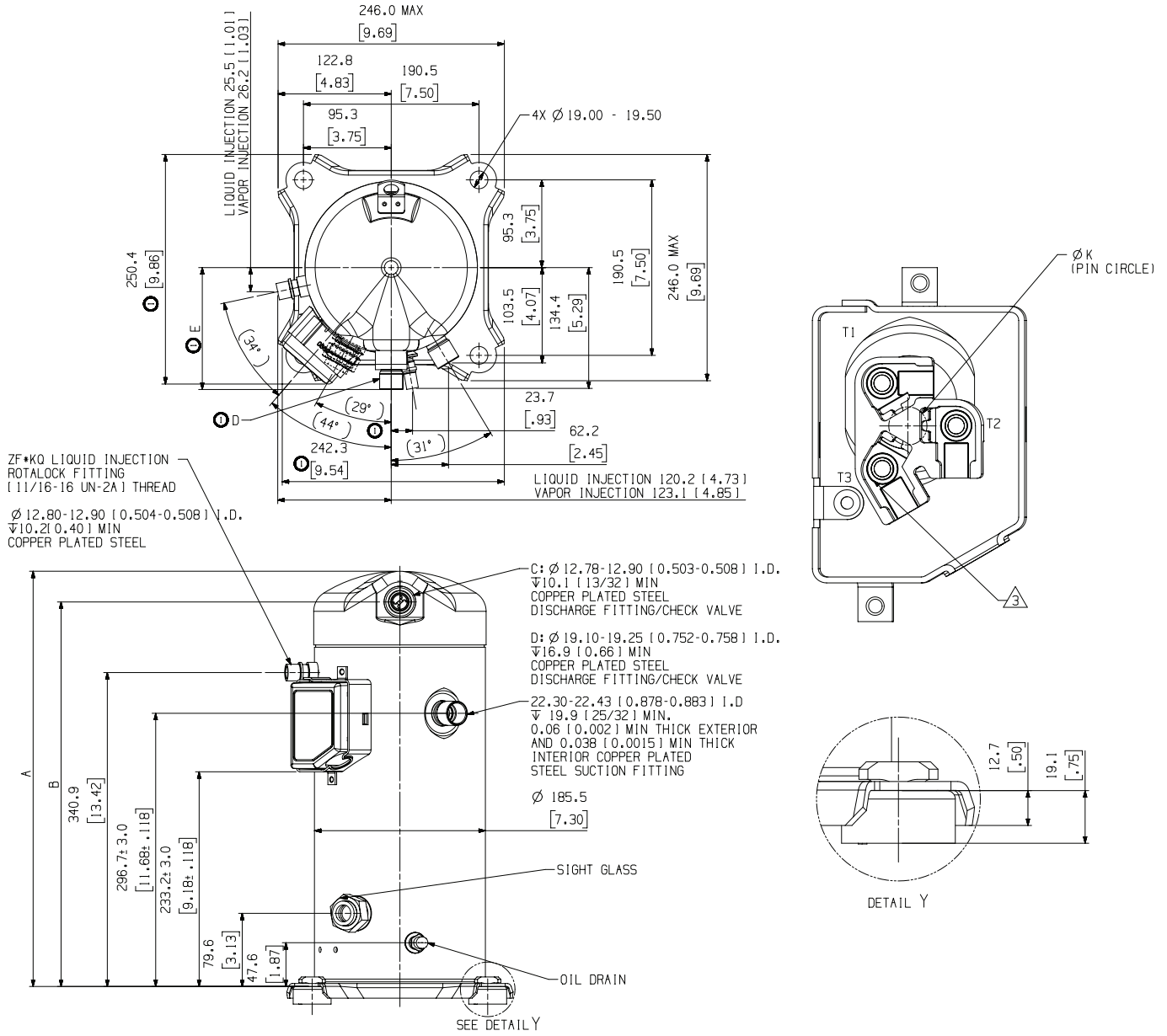

Model number	mm (in)		Discharge fitting
	A±3.0	B	
ZFI20KQE	442.0 [17.40]	409.6 [16.13]	C
ZFI23KQE			D
ZFI26KQE			D
ZFI36KQE			D
ZFI39KQE	451.0 [17.76]	418.6 [16.48]	D

**Notes:**

- (1) All tolerances ± 1.5mm [0.06in] unless otherwise specified
- (2) Due to accumulated assembly tolerances, the listed components may vary from the mounting holes. All fittings: ± 3.0mm [0.12in]
- (3) Tube ends must be plugged
- (4) All units are in mm[inch]

# Dimensional drawings

## ZF34KQE - ZF41KQE (BOM 554)

### Stub tube connection

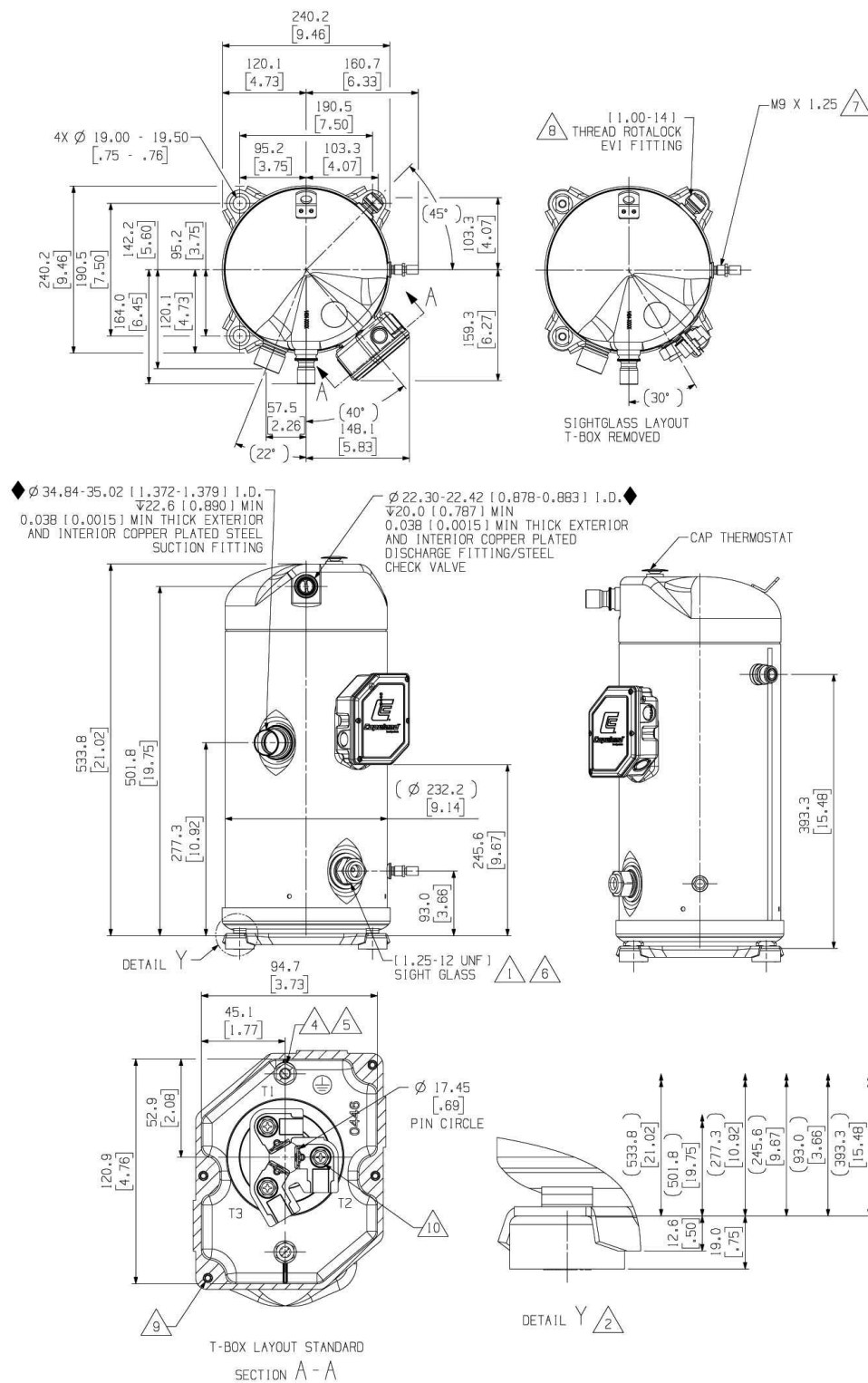

#### Notes:

- (1) All tolerances  $\pm 1.5\text{mm}$  [0.06in] unless otherwise specified
- (2) Due to accumulated assembly tolerances, the listed components may vary from the mounting holes. All fittings:  $\pm 3.0\text{mm}$  [0.12in]
- (3) Tube ends must be plugged
- (4) All units are in mm[inch]

# Dimensional drawings

## ZF49/54KQE-TFD/TF7 (BOM 554)

### Stub tube connection

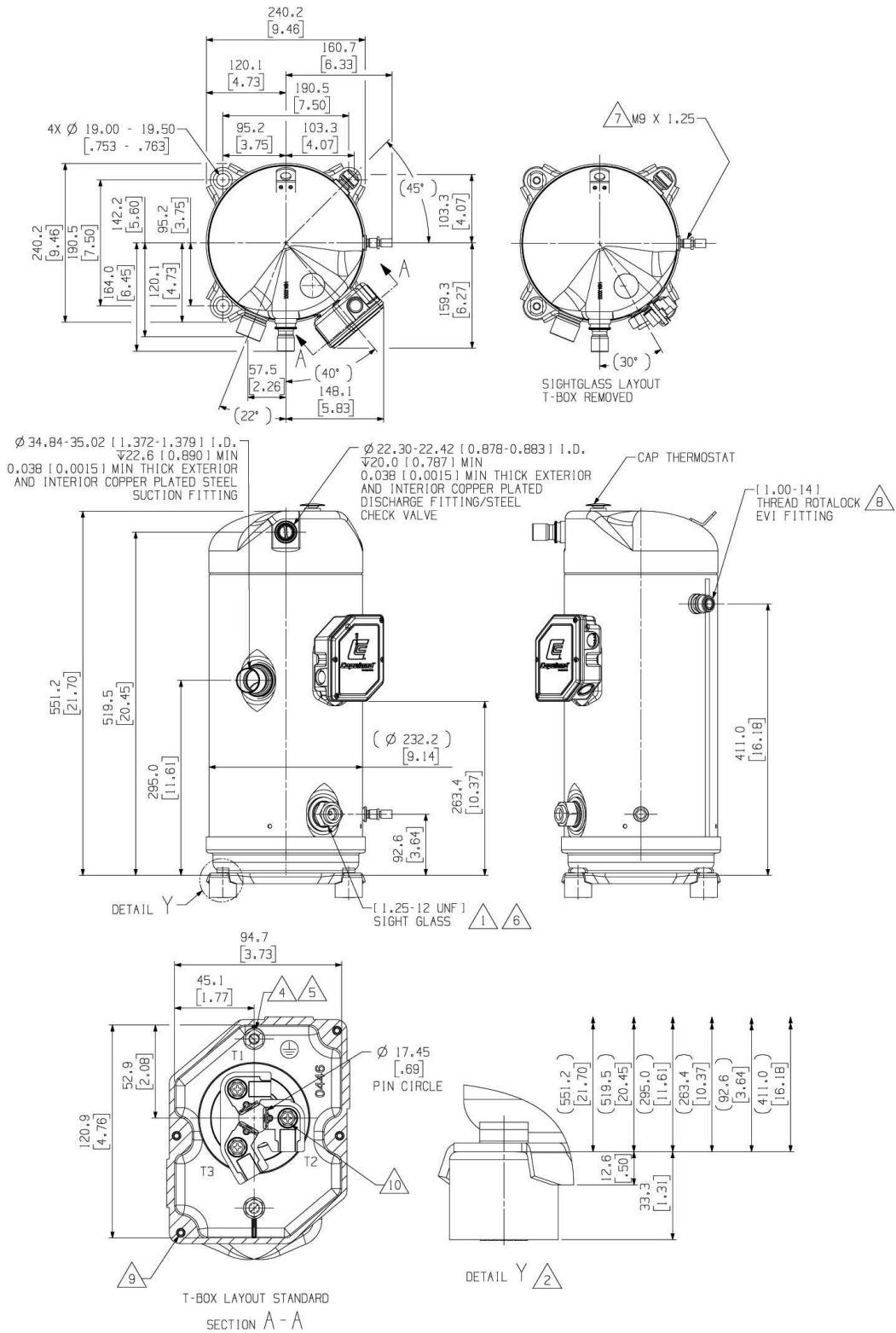

#### Notes:

- (1) All tolerances  $\pm 1.5\text{mm}$  [0.06in] unless otherwise specified
- (2) Due to accumulated assembly tolerances, the listed components may vary from the mounting holes. All fittings:  $\pm 3.0\text{mm}$  [0.12in]
- (3) Tube ends must be plugged
- (4) All units are in mm[inch]

# Dimensional drawings

## ZF49/54KQE-TFC and ZFI68/81KQE-TFC (BOM 554)

### Stub tube connection

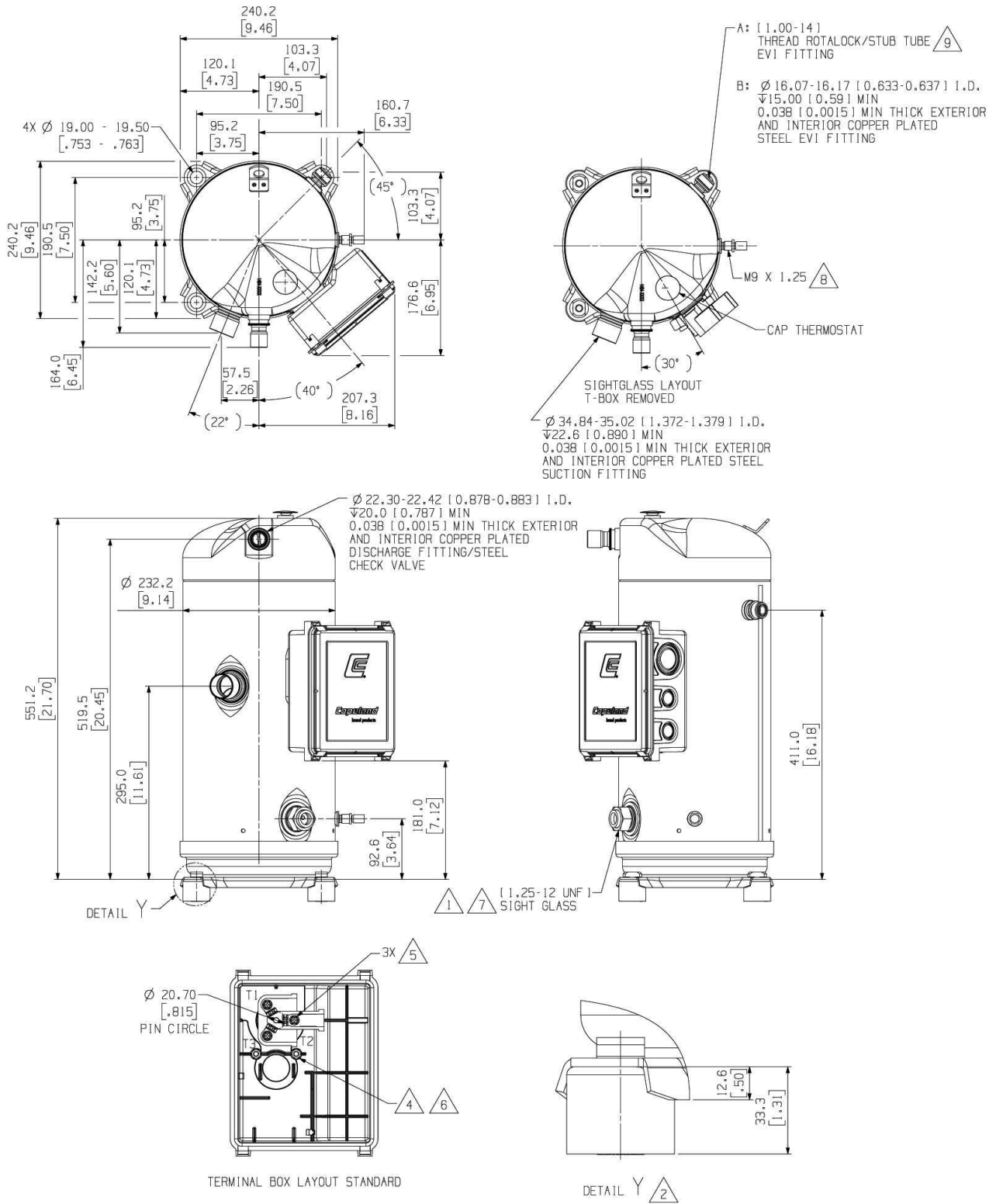

**Notes:**

- (1) All tolerances ± 1.5mm [0.06in] unless otherwise specified
- (2) Due to accumulated assembly tolerances, the listed components may vary from the mounting holes. All fittings: ± 3.0mm [0.12in]
- (3) Tube ends must be plugged
- (4) All units are in mm[inch]



# Dimensional drawings

## ZFI68/81KQE-TFD/TF7 (BOM 554)

### Stub tube connection

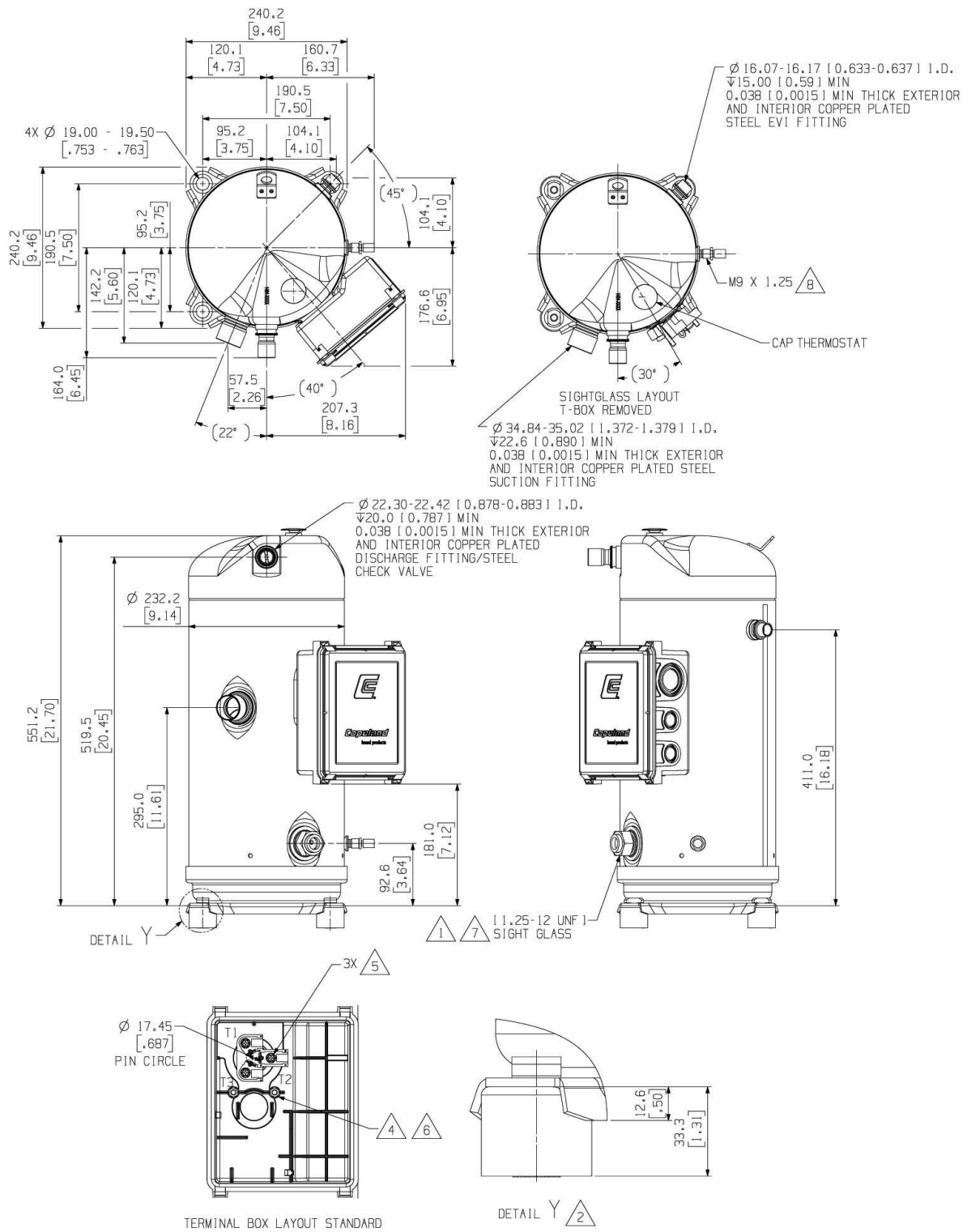

#### Notes:

- (1) All tolerances  $\pm 1.5\text{mm}$  [0.06in] unless otherwise specified
- (2) Due to accumulated assembly tolerances, the listed components may vary from the mounting holes. All fittings:  $\pm 3.0\text{mm}$  [0.12in]
- (3) Tube ends must be plugged
- (4) All units are in mm[inch]





# Dimensional drawings

## DTC Valve prints

### ZF06-28

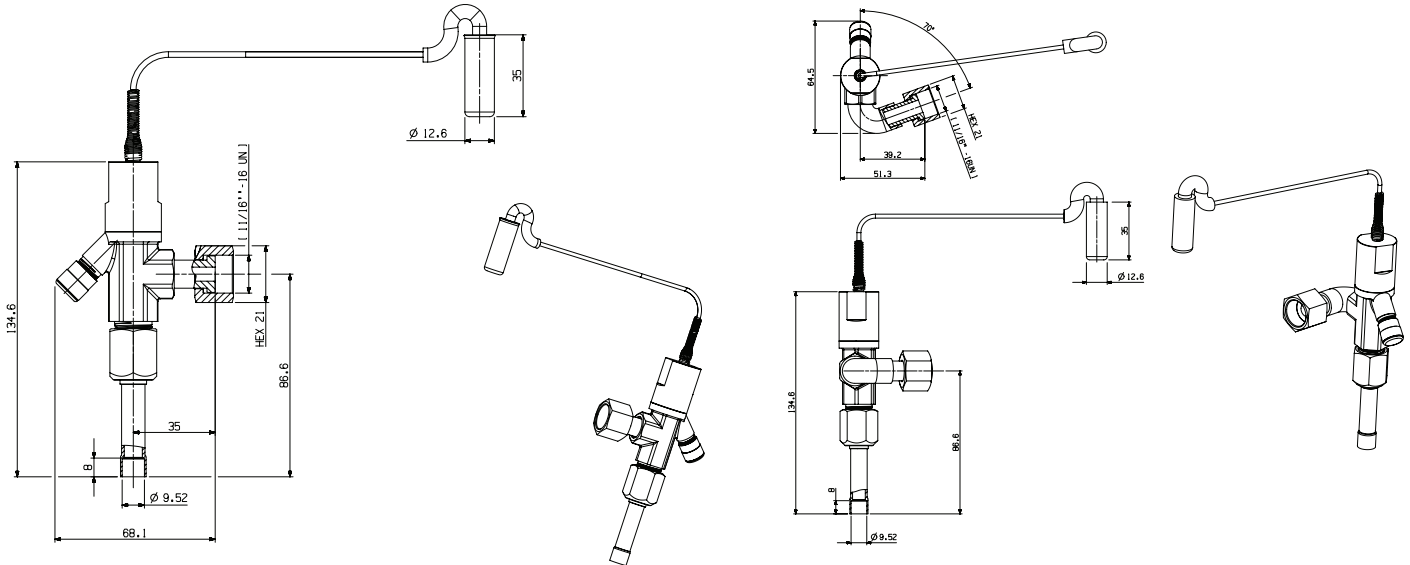

### ZF34-54

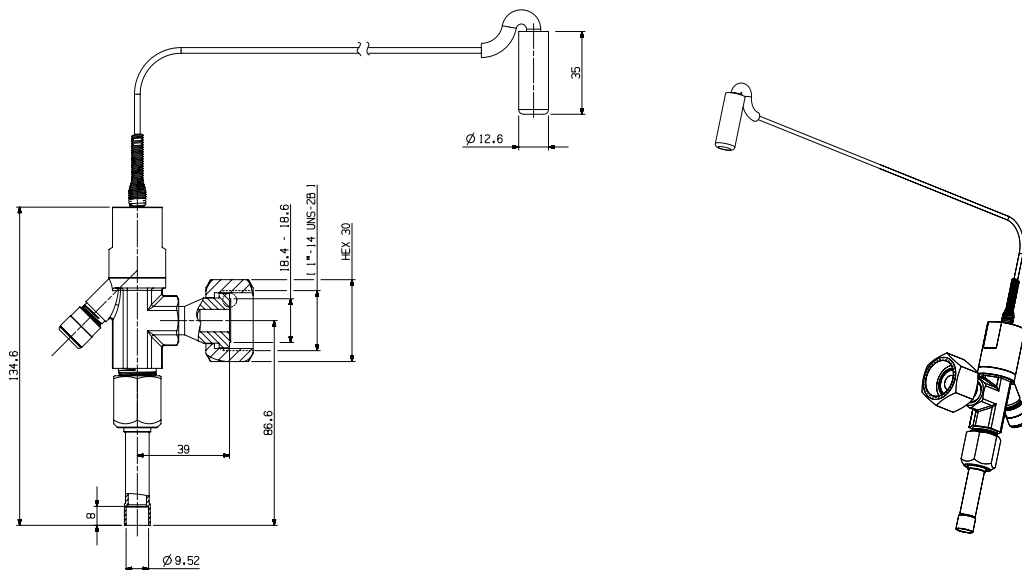

Note: Unit is mm

# Dimensional drawings

## CoreSense module

### ZFI20 - ZFI140

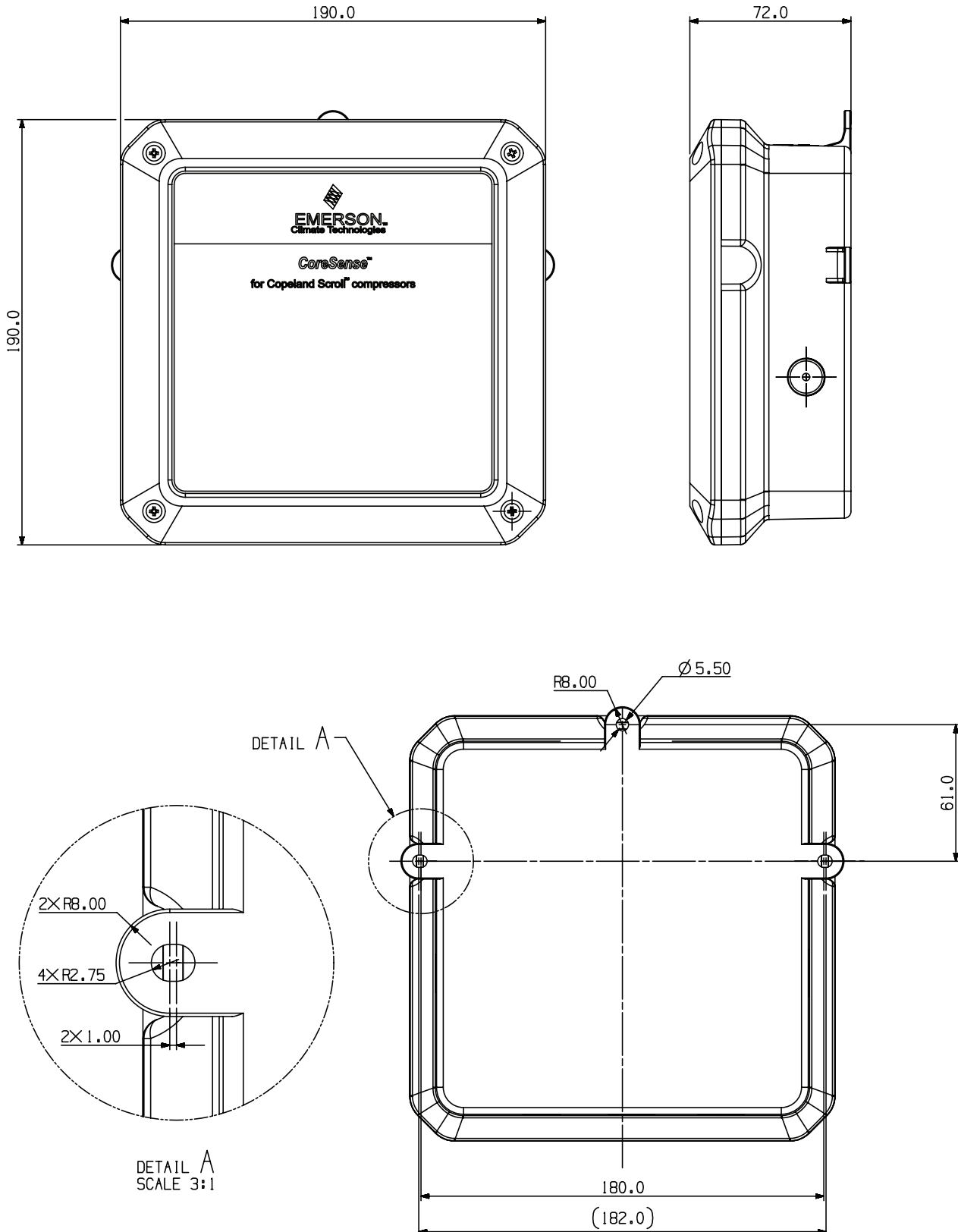

Note: Unit is mm

# Schematic diagram

## Liquid injection schematic

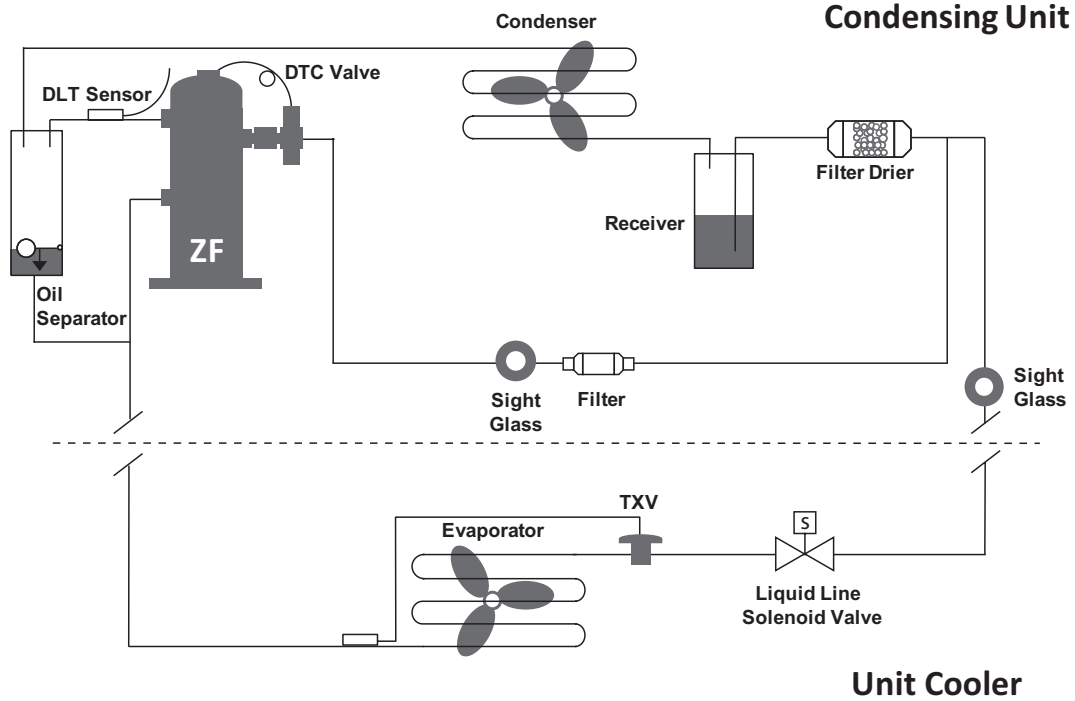

## Vapor injection schematic

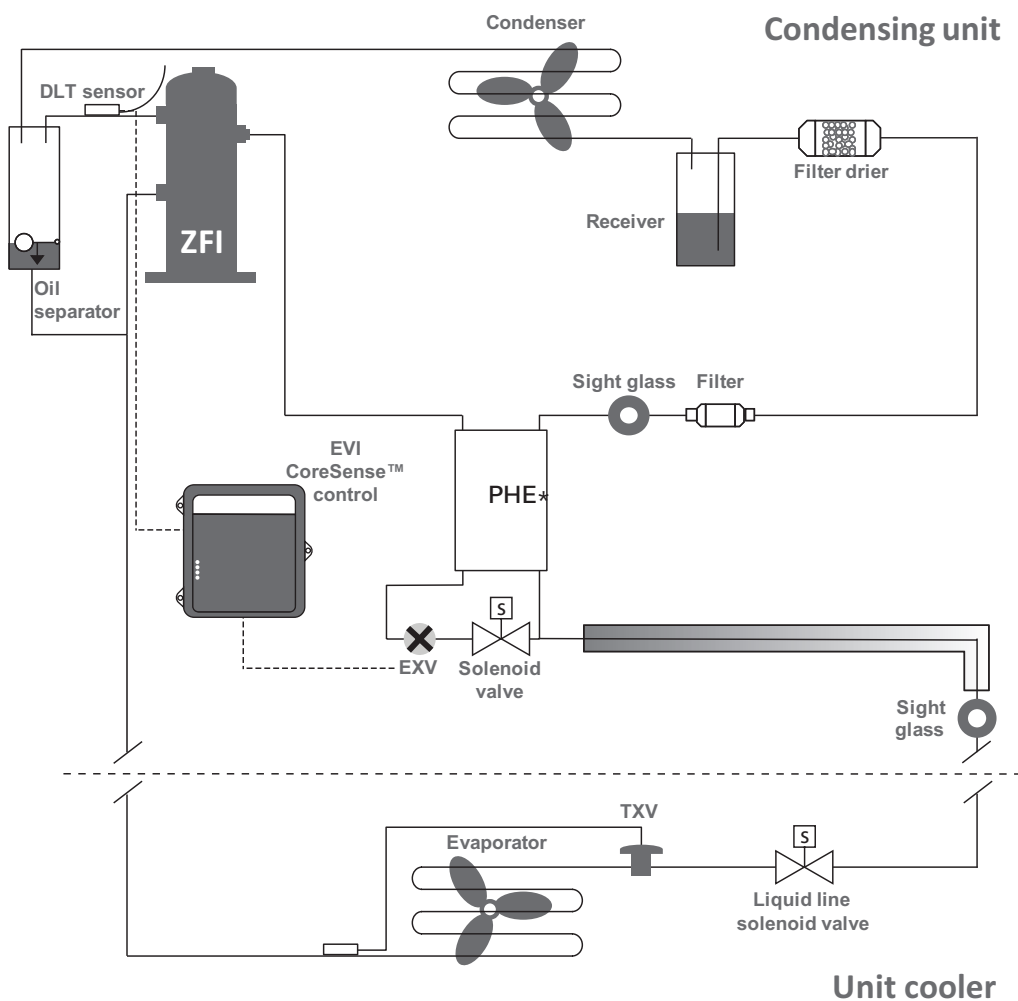

\*PHE: Plate heat exchanger

## Available models – ZF Liquid injection

Model	ZF Liquid injection models			
	Rotalock	Stub tube	Manufacturing plant	Status
TFD 380-420V-3ph-50Hz; 460V-3ph-60Hz	ZF06KQE-TFD-551	ZF06KQE-TFD-550	Thailand	Active
	ZF08KQE-TFD-551	ZF08KQE-TFD-550	Thailand	Active
	ZF09KQE-TFD-551	ZF09KQE-TFD-550	Thailand	Active
	ZF11KQE-TFD-551	ZF11KQE-TFD-550	Thailand	Active
	ZF13KQE-TFD-551	ZF13KQE-TFD-550	Thailand	Active
	ZF15KQE-TFD-551	ZF15KQE-TFD-550	Thailand	Active
	ZF18KQE-TFD-551	ZF18KQE-TFD-550	Thailand	Active
	ZF25KQE-TFD-551	ZF25KQE-TFD-550	Thailand	Active
	ZF28KQE-TFD-551	ZF28KQE-TFD-550	Thailand	Active
	ZF34KQE-TFD-564	ZF34KQE-TFD-554	Thailand	Active
	ZF41KQE-TFD-564	ZF41KQE-TFD-554	Thailand	Active
	ZF49KQE-TFD-564	ZF49KQE-TFD-554	Thailand	Active
	ZF54KQE-TFD-564	ZF54KQE-TFD-554	Thailand	Active
TF5 200-220V-3ph-50Hz; 200-230V-3ph-60Hz  TFC 200V-3ph-50Hz; 208-230V-3ph-60Hz	ZF06KQE-TF5-551	ZF06KQE-TF5-550	Thailand	Active
	ZF08KQE-TF5-551	ZF08KQE-TF5-550	Thailand	Active
	ZF09KQE-TF5-551	ZF09KQE-TF5-550	Thailand	Active
	ZF11KQE-TF5-551	ZF11KQE-TF5-550	Thailand	Active
	ZF13KQE-TFC-551	ZF13KQE-TFC-550	Thailand	Active
	ZF13KQE-TFC-551	ZF13KQE-TFC-550	Thailand	Active
	ZF15KQE-TFC-551	ZF15KQE-TFC-550	Thailand	Active
	ZF18KQE-TFC-551	ZF18KQE-TFC-550	Thailand	Active
	ZF25KQE-TFC-551	ZF25KQE-TFC-550	Thailand	Active
	ZF28KQE-TFC-591	ZF28KQE-TFC-580	Thailand	Active
	ZF34KQE-TFC-564 / 567	ZF34KQE-TFC-554	Thailand	Active
	ZF41KQE-TFC-564 / 567	ZF41KQE-TFC-554	Thailand	Active
	ZF49KQE-TFC-564 / 567	ZF49KQE-TFC-554	Thailand	Active
ZF54KQE-TFC-564 / 567	ZF54KQE-TFC-554	Thailand	Active	
TF7 380V-3ph-60Hz	ZF13KQE-TF7-551	ZF13KQE-TF7-550	Thailand	Active
	ZF15KQE-TF7-551	ZF15KQE-TF7-550	Thailand	Active
	ZF18KQE-TF7-551	ZF18KQE-TF7-550	Thailand	Active
	ZF25KQE-TF7-551	ZF25KQE-TF7-550	Thailand	Active
	ZF28KQE-TF7-551	ZF28KQE-TF7-550	Thailand	Active
	ZF34KQE-TF7-564 / 567	ZF34KQE-TF7-554	Thailand	Active
	ZF41KQE-TF7-564 / 567	ZF41KQE-TF7-554	Thailand	Active
	ZF49KQE-TF7-564 / 567	ZF49KQE-TF7-554	Thailand	Active
	ZF54KQE-TF7-564 / 567	ZF54KQE-TF7-554	Thailand	Active
PFV 200V-1ph-50Hz; 208-230V-1ph-60Hz	ZF06KQE-PFV-551	ZF06KQE-PFV-550	Thailand	Active
	ZF08KQE-PFV-551	ZF08KQE-PFV-550	Thailand	Active
	ZF09KQE-PFV-551	ZF09KQE-PFV-550	Thailand	Active
	ZF11KQE-PFV-551	ZF11KQE-PFV-550	Thailand	Active
	ZF13KQE-PFV-551	ZF13KQE-PFV-550	Thailand	TBD
	ZF15KQE-PFV-551	ZF15KQE-PFV-550	Thailand	TBD

**Notes:** Please select the right BOMs when ZF150-81 models are used in Rack application (BOM554/564 for OMB and 567 for OM3)

## Available models – ZFI Vapor injection

Model	ZFI Vapor injection models			
	Rotalock	Stub tube	Manufacturing plant	Status
TFD/TED 380-420V-3ph-50Hz; 460V-3ph-60Hz	ZFI20KQE-TFD-552	ZFI20KQE-TFD-550	Thailand	Active
	ZFI23KQE-TFD-552	ZFI23KQE-TFD-550	Thailand	Active
	ZFI26KQE-TFD-552	ZFI26KQE-TFD-550	Thailand	Active
	ZFI36KQE-TFD-552	ZFI36KQE-TFD-550	Thailand	Active
	ZFI39KQE-TFD-552	ZFI39KQE-TFD-550	Thailand	Active
	ZFI50KQE-TFD-564 / 567	ZFI50KQE-TFD-554	Thailand	Active
	ZFI59KQE-TFD-564 / 567	ZFI59KQE-TFD-554	Thailand	Active
	ZFI68KQE-TFD-564 / 567	ZFI68KQE-TFD-554	Thailand	Active
	ZFI81KQE-TFD-564 / 567	ZFI81KQE-TFD-554	Thailand	Active
	ZFI96KQE-TED-523	ZFI96KQE-TED-522	Suzhou, China	Active
	ZFI122KQE-TED-523	ZFI122KQE-TED-522	Suzhou, China	Active
	ZFI140KQE-TED-523	ZFI140KQE-TED-522	Suzhou, China	Active
	TFC/TEC 200V-3ph-50Hz; 208-230V-3ph-60Hz	ZFI20KQE-TFC-552	ZFI20KQE-TFC-550	Thailand
ZFI23KQE-TFC-552		ZFI23KQE-TFC-550	Thailand	Active
ZFI26KQE-TFC-552		ZFI26KQE-TFC-550	Thailand	Active
ZFI36KQE-TFC-552		ZFI36KQE-TFC-550	Thailand	Active
ZFI39KQE-TFC-592		ZFI39KQE-TFC-580	Thailand	Active
ZFI50KQE-TFC-564 / 567		ZFI50KQE-TFC-554	Thailand	Active
ZFI59KQE-TFC-564 / 567		ZFI59KQE-TFC-554	Thailand	Active
ZFI68KQE-TFC-564 / 567		ZFI68KQE-TFC-554	Thailand	Active
ZFI81KQE-TFC-564 / 567		ZFI81KQE-TFC-554	Thailand	Active
ZFI96KQE-TEC-523		ZFI96KQE-TEC-522	Suzhou, China	Active
ZFI122KQE-TEC-523		ZFI122KQE-TEC-522	Suzhou, China	Active
ZFI140KQE-TEC-523		ZFI140KQE-TEC-522	Suzhou, China	Active
TF7/TE7 380V-3ph-60Hz		ZFI20KQE-TF7-552	ZFI20KQE-TF7-550	Thailand
	NA	ZFI23KQE-TF7-550	Thailand	Active
	ZFI26KQE-TF7-552	ZFI26KQE-TF7-550	Thailand	Active
	ZFI36KQE-TF7-552	ZFI36KQE-TF7-550	Thailand	Active
	ZFI39KQE-TF7-552	ZFI39KQE-TF7-550	Thailand	Active
	ZFI50KQE-TF7-564 / 567	ZFI50KQE-TF7-554	Thailand	Active
	ZFI59KQE-TF7-564 / 567	ZFI59KQE-TF7-554	Thailand	Active
	ZFI68KQE-TF7-564 / 567	ZFI68KQE-TF7-554	Thailand	Active
	ZFI81KQE-TF7-564 / 567	ZFI81KQE-TF7-554	Thailand	Active
	ZFI96KQE-TE7-523	ZFI96KQE-TE7-522	Suzhou, China	Active
	ZFI122KQE-TE7-523	ZFI122KQE-TE7-522	Suzhou, China	Active
	ZFI140KQE-TE7-523	ZFI140KQE-TE7-522	Suzhou, China	Active

**Notes:** Please select the right BOMs when ZFI50-81 models are used in Rack application (BOM554/564 for OMB and 567 for OM3)

## ZF06-54, ZFI20-140 Accessory list

Item	Parts	Part Number	Description
1	Mounting Kits for Single Unit	527-0116-00	Mounting for single, 35-45 durometer, 1.45"OD, 0.44"ID, 0.75"Height
	Mounting Kits for Single Unit	527-0210-00	Mounting for single, 55-65 durometer, 1.62"OD, 0.44"ID, 1.75"Height
	Mounting Kits for Single Unit	527-0175-02	Mounting for single, 40 durometer, 2.17"OD, 0.50"ID, 0.75"Height
	Mounting Kits for Rack Unit	527-0157-00	High Durometer(60-70) Mounting for Rack, 1.62"OD, 0.44"ID, 1.16"Height
	Mounting Kits for Rack Unit	998-0178-00	Hard Mounting for Rack, 1.87"OD, 0.69"ID, 0.31"Height
2	Crankcase Heater	018-0095-04	Crankcase Heater, 240V, 70W, 48"(120cm) Lead length, 48"(120cm) Ground wire
	Crankcase Heater	018-0095-05	Crankcase Heater, 480V, 70W, 48"(120cm) Lead length, 48"(120cm) Ground wire
	Crankcase Heater	018-0091-22	Crankcase Heater, 240V, 90W, 48"(120cm)Lead length, 48"(120cm) Ground wire
	Crankcase Heater	018-0091-23	Crankcase Heater, 480V, 90W, 48"(120cm)Lead length, 48"(120cm) Ground wire
	Crankcase Heater	018-0091-09	Crankcase Heater, 240V, 140W, 71cm Lead length, 71cm Ground wire
3	DTC Kits	510-0875-01	DTC Valve 120°C, 11/16", Liquid line Ø9.52mm (ALCO 802504)
	DTC Kits	510-0875-02	DTC Valve 120°C, 11/16" with 70° Outlet, Liquid line Ø9.52mm (ALCO 802506)
	DTC Kits	510-0875-00	DTC Valve 120°C, 1", Liquid line Ø9.52mm (ALCO 802505)
4	Discharge Line Thermostat	085-0248-00	Discharge line thermostat with clip (8409496), 130°C, 5/8" clip
	Discharge Line Thermostat	085-0227-00	Discharge Line Thermostat with clip (8615262), 130°C, 7/8" clip
5	Plate Heat Exchanger	067-0035-00	Plate Heat Exchanger B8TH x14
	Plate Heat Exchanger	067-0036-00	Plate Heat Exchanger B8TH x20
	Plate Heat Exchanger	067-0070-00	Plate Heat Exchanger B8TH x24
	Plate Heat Exchanger	067-0067-00	Plate Heat Exchanger B10TH x40
6	Suction & Discharge Valve Kits	998-5100-42	Suction & Discharge Valve with Seal (1 1/4" -12 Thread to 3/4" Sweat Suction Valve, 1'-14 Thread to 1/2" Sweat Discharge Valve)
	Suction & Discharge Valve Kits	998-5100-48	Suction & Discharge Valve with Seal (1 1/4" -12 Thread to 7/8" Sweat Suction Valve, 1'-14 Thread to 1/2" Sweat Discharge Valve)
	Suction & Discharge Valve Kits	998-5100-62	Suction & Discharge Valve with Seal (1 1/4" -12 Thread to 7/8" Sweat Suction Valve, 1 1/4"-12 Thread to 3/4" Sweat Discharge Valve)
	Suction & Discharge Valve Kits	998-5100-27	Suction & Discharge Valve with Seal (1 3/4"-12 Thread to 1 3/8" Sweat Suction Valve, 1 1/4"-12 Thread to 7/8" Sweat Discharge Valve)
	Discharge Service Valve	998-0510-46	Discharge Service Valve Kits, 1-3/4" Thread to 1-3/8" Sweat
7	Adapter Suction Rotalock to Stub	998-0034-13	Adapter Suction Rotalock to Stub (1 3/4"-12 Thread to 1 3/8" Sweat)
	Adapter Discharge Rotalock to Stub	998-0034-08	Adapter Discharge Rotalock to Stub (1 1/4"-12 Thread to 7/8" Sweat)
	Adapter Injection Rotalock to Stub	998-0034-18	Adapter Injection Rotalock to Stub (1'-14 Thread to 1/2" ID Sweat)
	Adapter Injection Rotalock to Stub	534-0072-00	Adapter Injection Rotalock to Stub (11/16" Thread to 1/2" ID Sweat)
	EVI Control Kits (China domestic)	562-0313-00	EVI Control Kits w/o CoreSense Box, Ø1.3mm EXV valve orifice size
8	EVI Control Kits (China domestic)	562-0313-01	EVI Control Kits w/o CoreSense Box, Ø1.65mm EXV valve orifice size
	EVI Control Kits (China domestic)	562-0313-02	EVI Control Kits w/o CoreSense Box, Ø1.8mm EXV valve orifice size
	EVI Control Kits (China domestic)	562-0313-03	EVI Control Kits w/o CoreSense Box, Ø2.4mm EXV valve orifice size
	EVI Control Kits (China domestic)	562-0291-01	EVI Control Kits with CoreSense Box, Ø1.3mm EXV valve orifice size, IP54
	EVI Control Kits (China domestic)	562-0291-02	EVI Control Kits with CoreSense Box, Ø1.65mm EXV valve orifice size, IP54
	EVI Control Kits (China domestic)	562-0291-03	EVI Control Kits with CoreSense Box, Ø1.8mm EXV valve orifice size, IP54
	EVI Control Kits (China domestic)	562-0291-06	EVI Control Kits with CoreSense Box, Ø2.4mm EXV valve orifice size, IP54
	Control Box	562-0292-00	EVI Control Board Assembly, with CoreSense Box
10	Control Board	543-0189-01	Control Board, fasten by screw in CoreSense Box, 4* Ø5mm holes at 61 x 101 mm centers
	Control Board	543-0219-01	Control Board, fasten by plastic stakes, 4* Ø4mm holes at 61 x 101 mm centers
11	Transformer	037-0029-00	Transformer, Input 220VAC, Output 12VAC, 50/60Hz
12	DLT Sensor	043-0277-00	DLT Sensor, 1800mm wire length
	DLT Sensor	043-0277-01	DLT Sensor, 4500mm wire length
13	Vapor in Sensor	043-0210-00	Vapor In Sensor, 1800mm wire length
	Vapor in Sensor	043-0278-00	Vapor In Sensor, 4500mm wire length
14	Vapor out Sensor	043-0210-02	Vapor out Sensor, 1800mm wire length
	Vapor out Sensor	043-0279-00	Vapor out Sensor, 4500mm wire length
15	EXV Filter	013-0212-00	EXV Filter, Liquid In Ø8.65mm ID, Liquid Out Ø6.5mm ID, 100 mesh
16	EXV-Coil	023-0111-00	EXV-Coil, 1796mm wire length
	EXV-Coil	023-0111-01	EXV-Coil, 4500mm wire length
17	EXV-Valve	010-0240-00	EXV valve, Ø1.3mm orifice size(TS113C0x), 2*Ø6.35mm OD
	EXV-Valve	010-0240-01	EXV valve, Ø1.65mm orifice size(TS116C0x), 2*Ø6.35mm OD
	EXV-Valve	010-0240-02	EXV valve, Ø1.8mm orifice size(TS118C0x), 2*Ø6.35mm OD
	EXV-Valve	010-0240-03	EXV valve, Ø2.4mm orifice size(TS124C0x), 2*Ø6.35mm OD
18	Cable gland	036-1310-01	Cable gland -1
	Cable gland	036-1439-00	Cable gland -2
	Cable gland	036-1426-00	Cable gland -3
19	Tube for sensor	028-3998-00	Tube for sensor
20	Spring clip	032-0962-00	Spring clip
21	Bolts group	521-0355-00	Bolts, 3pcs for CoreSense Box
22	CoreSense Module	571-0064-06	P47 CoreSense Module 120/220V

**Notes:** Standard: Included in the compressor; 1 or -1 : Option to choose either one





## Vapor injection scroll standard order list

Part Number		Description
Compressor	-	-
EVI control kits	562-0292-00	EVI Control Board Assembly, with CoreSense Box
	036-1310-01	Cable gland 1
	036-1439-00	Cable gland 2
	036-1426-00	Cable gland 3
	043-0277-00	DLT Sensor, 1800mm wire length
	043-0210-00	Vapor In Sensor, 1800mm wire length
	043-0210-02	Vapor out Sensor, 1800mm wire length
	028-3998-00	Tube for sensor
	032-0962-00	Spring clip
	521-0355-00	Bolts, 3pcs for CoreSense Box
	013-0212-00	EXV Filter, Liquid In Ø8.65mm ID, Liquid Out Ø6.5mm ID, 100 mesh
	023-0111-00	EXV-Coil, 1796mm wire length
	010-0240-00	EXV valve, Ø1.3mm orifice size(TS113C0x), 2*Ø6.35mm OD
	010-0240-01	EXV valve, Ø1.65mm orifice size(TS116C0x),2*Ø6.35mm OD
	010-0240-02	EXV valve, Ø1.8mm orifice size(TS118C0x), 2*Ø6.35mm OD
	010-0240-03	EXV valve, Ø2.4mm orifice size(TS124C0x), 2*Ø6.35mm OD
PHE	067-0035-00	Plate Heat Exchanger B8TH x14
	067-0036-00	Plate Heat Exchanger B8TH x20
	067-0070-00	Plate Heat Exchanger B8TH x24
	067-0067-00	Plate Heat Exchanger B10TH x40



Unit, Pcs	Vapor injection models												Source
	ZFI20	ZFI23	ZFI26	ZFI36	ZFI39	ZFI50	ZFI59	ZFI68	ZFI81	ZFI96	ZFI122	ZFI140	
1	ZFI20KQE -TFD7/C -552/550	ZFI23KQE -TFD7/C -552/550	ZFI26KQE -TFD7/C -552/550	ZFI36KQE -TFD7/C -552/550	ZFI39KQE -TFD/7 -552/550	ZFI50KQE -TFD7/C -564/567/554	ZFI59KQE -TFD7/C -564/567/554	ZFI68KQE -TFD7/C -564/567/554	ZFI81KQE -TFD7/C -564/567/554	ZFI96KQE -TFD7/C -523/522	ZFI122KQE -TFD7/C -523/522	ZFI140KQE -TFD7/C -523/522	ZFI20-81 in Thailand ZFI96-140 in Suzhou
1	.	.	.	.	.	.	.	.	.	.	.	.	Suzhou
1	.	.	.	.	.	.	.	.	.	.	.	.	Suzhou
1	.	.	.	.	.	.	.	.	.	.	.	.	Suzhou
1	.	.	.	.	.	.	.	.	.	.	.	.	Suzhou
1	.	.	.	.	.	.	.	.	.	.	.	.	Suzhou
1	.	.	.	.	.	.	.	.	.	.	.	.	Suzhou
1	.	.	.	.	.	.	.	.	.	.	.	.	Suzhou
3	.	.	.	.	.	.	.	.	.	.	.	.	Suzhou
3	.	.	.	.	.	.	.	.	.	.	.	.	Suzhou
1	.	.	.	.	.	.	.	.	.	.	.	.	Suzhou
1	.	.	.	.	.	.	.	.	.	.	.	.	Suzhou
1	.	.	.	.	.	.	.	.	.	.	.	.	Suzhou
1	.	.	.	-	-	-	-	-	-	-	-	-	Suzhou (562-0291-01)*
1	-	-	-	.	.	.	.	-	-	-	-	-	Suzhou (562-0291-02)*
1	-	-	-	-	-	-	-	.	.	-	-	-	Suzhou (562-0291-03)*
1	-	-	-	-	-	-	-	-	-	.	.	.	Suzhou (562-0291-06)*
1	.	.	.	.	.	-	-	-	-	-	-	-	Suzhou
1	-	-	-	-	-	.	.	.	-	-	-	-	Suzhou
1	-	-	-	-	-	-	-	-	.	-	-	-	Suzhou
1	-	-	-	-	-	-	-	-	-	.	.	.	Suzhou

\* Bundle kits package

## Sound jacket

Copeland has developed a new sound jacket for noise sensitive applications. It is designed to be factory mounted by the equipment manufacturers or to be easily installed on site.

The sound jacket perfectly fits Copeland scroll refrigeration compressors from 7 to 30 HP including "Summit" and "Large Refrigeration Scroll" series compressors. The sound jacket provides an overall sound attenuation of 6 to 8 dB(A) making Copeland scroll compressors the lowest noise solution currently available in the market.

It contains 3 pieces in one carton box, including shell cover, top cap cover and terminal box cover.

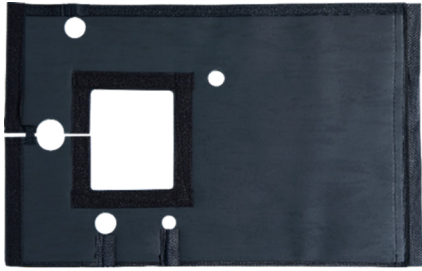

Shell cover



Top cap cover



Terminal box cover



Scroll compressor with and without sound jacket

## Example: Sound power with and without sound jacket

### ZB88 Medium temp scroll example

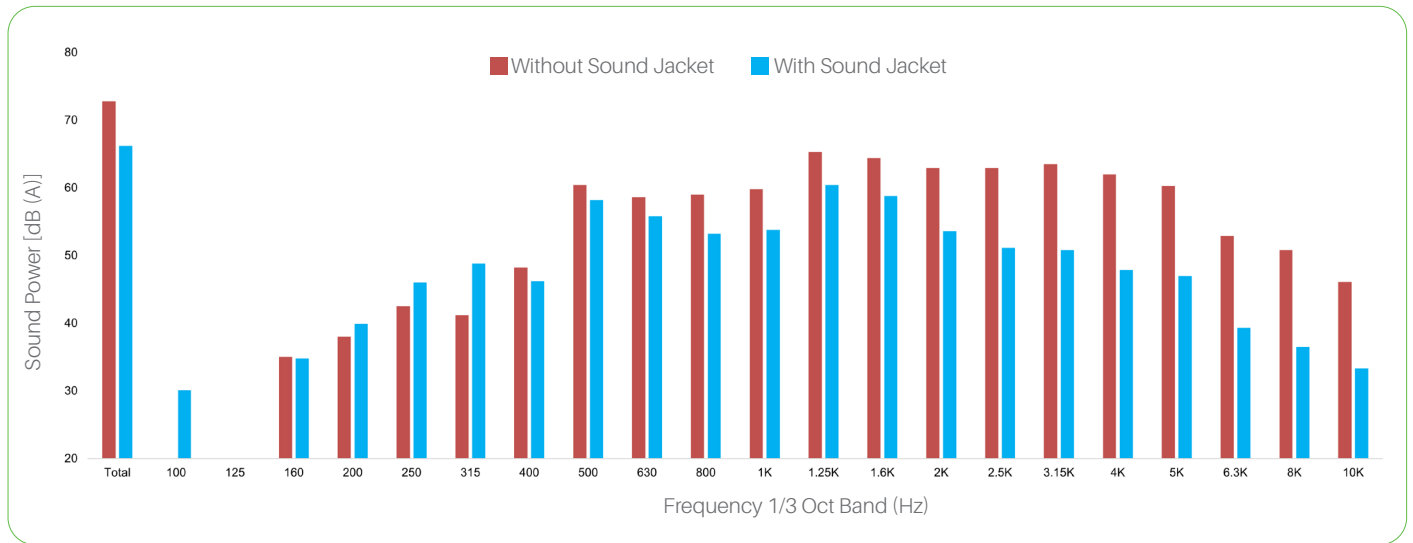

### ZFI68 Low temp scroll example

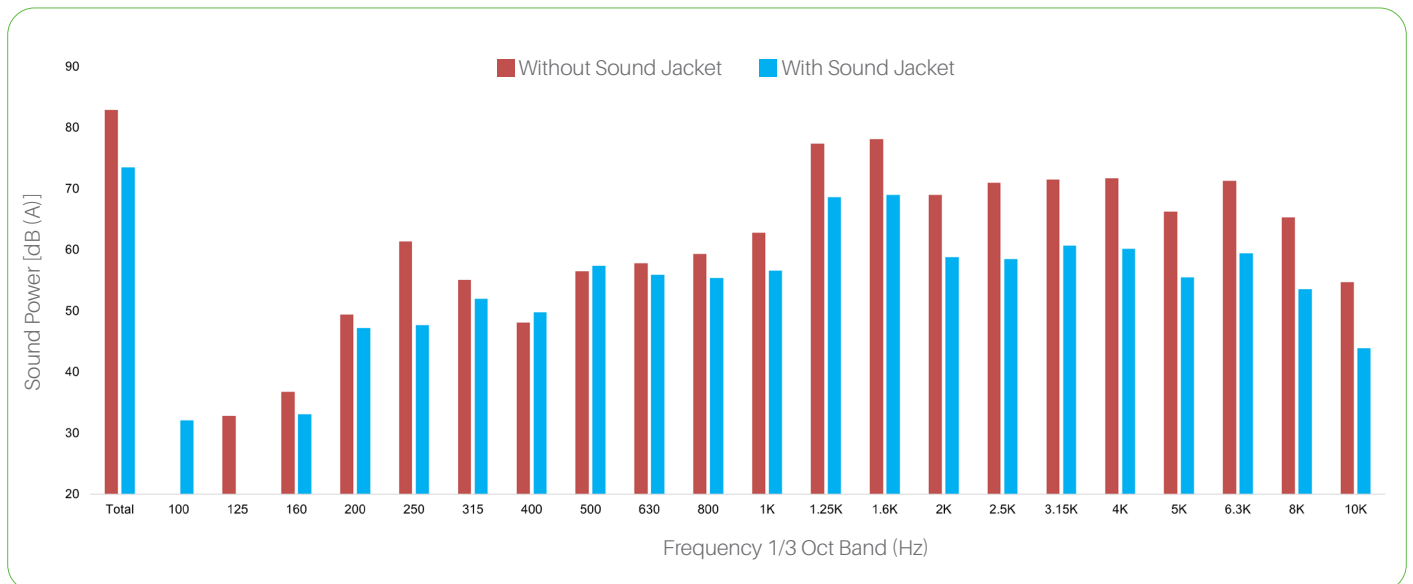

## Customer order part number

Platform	Part number	Applied models	Source
Summit	505-1501-04	ZB58KQ/E	Suzhou
	505-1501-03	ZB66KQ/E, ZB76KQ/E, ZB88KQ	
	505-1501-01	ZB95KQ/E, ZB114KQ/E (TW* motor)	
	505-1501-06	ZB95KQ/E, ZB114KQ/E (TF* motor)	
	505-1501-05	ZB130KQ/E	
	505-1501-02	ZFI50KQE, ZFI59KQE	
	505-1501-00	ZFI68KQE, ZFI81KQE	
Large Refrigeration Scroll	505-1512-00	ZB150KQ/E	Suzhou
	505-1512-01	ZB190KQ/E, ZB220KQ/E	
	505-1512-02	ZFI96KQE, ZFI122KQE, ZFI140KQE	

## General information

Technical data are correct at the time of printing. Updates may occur, and should you need confirmation of a specific value, please contact Emerson stating clearly the information required.

Emerson cannot be held responsible for errors in capacities, dimensions, etc., stated herein. Products, specifications and data in this literature are subject to change without notice.

The information given herein is based on data and tests which Emerson believes to be reliable and which are in accordance with today's technical knowledge. It is intended for use by persons having the appropriate technical knowledge and skill, at their own discretion and risk. Our products are designed and adapted for fixed locations. For mobile applications, failures may occur.

The suitability for this has to be assured from the plant manufacturer, which may include making appropriate tests.

### Note:

The components listed in this catalogue are not released for use with caustic, poisonous or flammable substances. Emerson cannot be held responsible for any damage caused by using these substances.



# Contact Us

## Asia Pacific Headquarters

Suite 2503-10A, 25/F, Exchange Tower,  
33 Wang Chiu Road, Kowloon Bay,  
Kowloon, Hong Kong  
Tel: (852) 2866 3108  
Fax: (852) 2520 6227

## Australia

356 Chisholm Road  
Auburn NSW 2144, Australia  
Tel: (612) 9795 2800  
Fax: (612) 9738 1699

## China - Beijing

Room 1203-1205,  
North Wing Junefield Plaza Central Tower,  
No. 10 Xuan Wu Men Wai Street,  
XiCheng District, Beijing, PRC  
Tel: (8610) 5095 2188

## China - Guangzhou

Guangzhou Office  
Unit 2202B, 22/F, Leatop Plaza,  
32 Zhujiang East Road, Tianhe Dist.,  
Guangzhou 510623, PRC  
Tel: (8620) 8595 5188

## China - Shanghai

Shanghai Sales Office  
7/F, Emerson Building, 1582 Gumei  
Rd, Shanghai, PRC  
Tel: (8621) 3338 7333

## India - Mumbai

601-602, 6/F Delphi B-Wing,  
Central Avenue,  
Hiranandani Business Park,  
Powai, Mumbai 400076, India  
Tel: (9122) 6786 0793  
Fax: (9122) 6662 050

## India - Pune

Plot No. 23, Rajiv Gandhi Infotech Park,  
Phase - II, Hinjewadi,  
Pune 411 057, Maharashtra, India  
Tel: (9120) 4200 2000  
Fax: (9120) 4200 2099

## Indonesia

23/F North Tower,  
Sampoerna Strategic Square-  
Jl. Jend. Sudirman Kav. 45-46,  
12930, Jakarta Indonesia  
Tel: (6221) 2509 1400,  
(6221) 5793 1000  
Fax: (6221) 5793 0883

## Japan

No. 3-9-5 Shin-Yokohama,  
Shin-yokohama Tosho Building,  
Kohoku-ku, Yokohama,  
222-0033 Japan  
Tel: (8145) 475 6371  
Fax: (8145) 475 3565

## Malaysia

No. 1, Block A  
Jalan SS13/5 Subang Jaya  
Selangor 47500, Malaysia  
Tel: (603) 5624 2888

## Middle East & Africa

PO Box 26382  
Jebel Ali Free Zone - South  
Dubai, UAE  
Tel: (9714) 811 8100  
Fax: (9714) 886 5465

## Philippines

10/F SM Cyber West Avenue,  
EDSA cor. West Avenue,  
Barangay Bungad, Diliman,  
Quezon City 1105, Philippines  
Tel: (632) 689 7200 ext. 4395

## Saudi Arabia

PO Box 34332  
3620 Building 7874, Unit 1,  
67th street 2nd Industrial City  
Dammam, Saudi Arabia  
Toll Free: 800 844 3426  
Tel: (966) 3814 7560  
Fax: (966) 3814 7570

## South Korea

14/F, NIA Building,  
Cheonggyecheon-ro,  
Jung-gu 04520, Seoul Korea  
Tel: (822) 3483 1500  
Fax: (822) 592 7883

## Taiwan

3/F, No. 122 Lane 235,  
Pao Chiau Rd., XinDianv Dist.,  
New Taipei City 23145, Taiwan (R.O.C.)  
Tel: (8862) 8912 1360  
Fax: (8862) 8912 1890

## Thailand

34/F, Interlink Tower,  
1558/133, Bangna Tai,  
Bangkok 10260, Thailand  
Tel: (662) 716 4700  
Fax: (662) 751 4241

## United Arab Emirates

PO Box 26382  
Jebel Ali Free Zone  
Dubai, UAE  
Toll Free: 800 441 3428  
Tel: (971) 4811 8100  
Fax: (971) 4886 5465

## Vietnam

9.04/F, Block A2, Viettel Tower  
285 Cach Mang Thang Tam, District 1  
Ho Chi Minh City, Vietnam  
Tel: (84) 28 6290 8243

[copeland.com](http://copeland.com)

Tel No.: 1800-209-1700 - [ClimateIndia@Copeland.com](mailto:ClimateIndia@Copeland.com)

Asia 03 00 Issued 09/2023  
©2023 Copeland LP. All rights reserved.



CopelandHQ



Copeland-HQ



Copeland\_HQ



Copeland\_HQ

Scan to visit:



Copeland